



ALUCOMPLAST Aluminum PLS.SAN.TIC.LTD.STI has been established in 1987 in ađlayan /Istanbul. Besides being in continuous development, ALUCOMPLAST Aluminium is a registered aluminum extruder manufacturer, of which the business is involved in Central Asia, Eastern Europe, Balkans and North Africa.

- The company continuously increases its brand name ALUCOMPLAST placing its trust in quality and efficiency in supporting customer satisfactions.

ALUCOMPLAST company is approved in compliance with the system of Quality Assurance Certificates in accordance with the requirements of the standard TSE 755-1, TSE 5247 EN 12020-1, TSE 4922 ve ISO 9001:200.

ALUCOMPLAST ALUMINIUM realizes its marketing, sales and customer relations in head office ađlayan. The firm places its trust in quality providing maximum in operation efficiency in supporting customer satisfactions. More than 21years the company provides its customers with quality products realizing its aluminum profile production in Sakarya /2.Organize Sanayi, covering an area of over 20 000 square meters and PVC production in Istanbul/ Tuzla Kimyaclar Organize Sanayi.

ađlayan Head Office: Marketing-Sales-Customer Care Services

In ađlayan Showroom we are serving the sale of aluminum and PVC accessories, hardware, PVC and Aluminum profile processing machines. Meeting our customers local and international needs in one sale point, we are one of the leading companies in aluminum sector who serves the highest quality of aluminum goods with a well-known reputation.

Aluminium Profiles Factory

Capabilities:

We are equipped with advanced production equipment ranging from 1400 UST, 1800 UST, 2750 UST extrusion press machines.

Production Lines:

Mold Production Line / 600 molds per year

Extrusion Line (1400, 1800 , 2750 and 4000 tons) / 1500 tons per month.

Anodic Oxidation Line / 800 tons per month.

2 Powder Coating Lines / 1000 tons per month.

Wooden Painted Line /100 ton per month.

Plastic Factory

Plastic Wall, Ceiling and Door Panels, Jalousie , and PVC Corner Joints production, 3 500 tones / per year.

Polyethylene goods production 1 000 ton / per year.



Our Certificate



**Authorization
to use the quality sign**

Qualanod

This is to certify that

Alucomplast s.r.o
Jachymovská 202/1 363 01 Ostrov

Licence number: 1612

is authorized to use the quality sign which is shown above according to the REGULATIONS FOR USE OF THE QUALANOD QUALITY LABEL FOR SULPHURIC ACID-BASED ANODIZING OF ALUMINIUM.

Date of issue of the licence: 20.10.2006
Period of validity of the licence: until 31.12.2013

Zurich, 15 October 2009

<p>QUALANOD</p> <p>Asmund Broll President</p>	<p>CERTIFICATION BODY</p> <p>Josef Schoppig AC-Fiduciaire SA</p>
--	---

Mailing address: QUALANOD, P.O. Box 1507, CH - 8027 Zurich
 Domicile: QUALANOD, c/o AC-Fiduciaire SA, Tödistrasse 47, CH - 8002 Zurich
 Phone: +41 (0)43 305 09 70/79
 Fax: +41 (0)43 305 09 08
 E-mail: info@qualanod.net
 Internet: www.qualanod.net



Alucomplast

**Standartni Profily
Standard Profiles**

L □ ○ ◊ - T

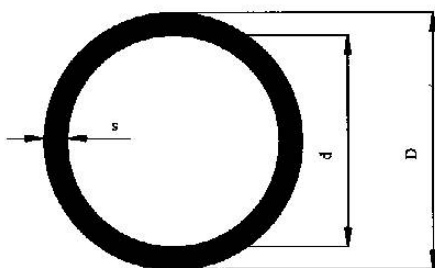

PROFIL NO	D	d	s	Kg/mt
1700	36	32	2	0.579
1701	63	57	3	1.531
1702	45	41	2	0.732
1703	19	17	1	0.152
1704	19	16.2	1.4	0.210
1705	65	42	11.5	5.238
1706	42	37	2.5	0.840
1707	14	11.6	1.2	0.130
1708	21.6	19	1.3	0.225
1709	25	22	1.5	0.301
1710	25	15	5	0.851
1711	30.5	25	2.75	0.650
1712	40	37	1.5	0.490
1713	19	16.5	1.25	0.190
1714	32	30	1	0.263
1715	49	43	3	1.173
1716	42	40	1	0.349
1717	30	25	2.5	0.585
1718	16	6.5	6.5	0.526
1719	24.7	21.1	1.8	0.349
1720	40	32	4	1.226
1721	25	23	1	0.203
1722	22	20	1	0.179
1723	35	33.1	1	0.290
1724	35	29	3	0.817
1725	21.5	19.90	0.8	0.141
1726	24	22.2	0.9	0.177
1727	27.5	22.5	2.5	0.532
1728	50.2	45	2.6	1.054
1729	28.5	26.3	1.1	0.257
1730	19.8	16.8	1.5	0.233

PROFIL NO	D	d	s	Kg/mt
1731	75.8	72.2	1.8	1.133
1732	30	26	2	0.477
1733	15.2	13	1.1	0.132
1734	18	8.5	4.75	0.536
1735	60	14	23	7.245
1736	30	24.5	2.75	0.638
1737	24	14	5	0.809
1738	60	52	4	1.907
1739	37.3	32.3	2.5	0.741
1740	32	14	9	1.762
1741	22	7	7.5	0.926
1742	40	36	2	0.647
1743	60	57.8	1.1	0.552
1744	100	97.4	1.3	1.092
1745	50	46	2	0.817
1746	50	45.2	2.4	0.973
1747	20	7	6.5	0.747
1748	40	38	1	0.332
1749	50	45	2.5	1.011
1750	16	12	2	0.238
1751	22	20.2	0.9	0.162
1752	25	17	4	0.715
1753	30	22	4	0.885
1754	50	46.4	1.8	0.740
1755	16	5	5.5	0.492
1756	30	24	3	0.690
1757	40	34	3	0.945
1758	120	114	3	2.989
1759	16	13	1.5	0.185
1760	16	8	4	0.409
1761	20	16	2	0.307

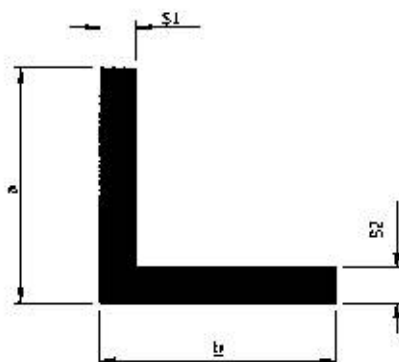

PROFIL NO	a	b	S1	S2	Kg/ml
1631	50	150	4	4	2.125
1632	10	30	1.5	1.5	0.157
1633	15	15	2	2	0.152
1634	15	25	2	2	0.206
1635	17	17	1.2	1.2	0.107
1636	15	15	1.5	1.5	0.116
1637	18	25	2	2	0.222
1638	10	40	3	3	0.382
1639	21	21	1.3	1.3	0.143
1640	30	30	3	3	0.463
1641	20	20	2	2	0.206
1642	27	27	1	1	0.144
1643	30	30	1.5	1.5	0.238
1644	17	38	1.5	1.5	0.217
1645	10	30	4	4	0.390
1646	18	25	3	3	0.325
1647	60	60	1.5	1.5	0.482
1648	50	50	2	2	0.531
1649	10.6	43.2	1.4	1.4	0.198
1650	15	30	2	2	0.233
1651	40	40	1.2	1.2	0.260
1652	35	35	2	2	0.368
1653	50	50	3	3	0.788
1654	30	60	5	5	1.151
1655	40	60	5	5	1.285
1656	200	50	2.2	2.2	1.477
1657	50	50	5	5	1.287
1658	20	40	3	3	0.463
1659	40	40	4	4	1.040
1660	13	20	7	5	0.423
3270	40	60	6	6	1.528
3339	20	80	2	2	0.521

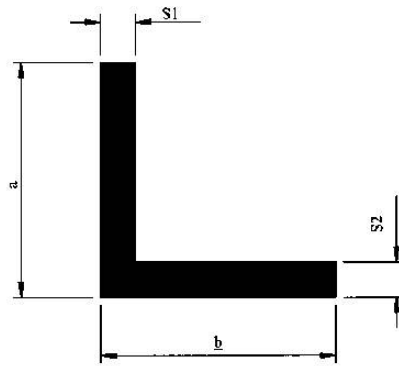

PROFIL NO	a	b	S1	S2	Kg/mt
1600	15	10	1.2	1.2	0.077
1601	15	15	1.2	1.2	0.094
1602	20	20	1.2	1.2	0.126
1603	20	40	1.2	1.2	0.191
1604	20	60	1.2	1.2	0.256
1605	25	25	1.2	1.2	0.159
1606	15	30	1.2	1.2	0.142
1607	30	30	1.2	1.2	0.191
1608	40	40	2	2	0.423
1609	40	40	4	4	0.824
1610	50	50	4	4	1.041
1611	30	50	10	10	1.897
1612	10	10	1.2	1.2	0.061
1613	15	25	3	3	0.301
1614	25	25	3	3	0.382
1615	10	20	1	1	0.079
1616	30	30	2	2	0.314
1617	32	32	3	3	0.496
1618	25	25	2.5	2.5	0.322
1619	22.7	26.2	5.6	9.6	0.880
1620	20	60	1.5	1.5	0.319
1621	20	50	1.5	1.5	0.278
1622	15	40	1.5	1.5	0.217
1623	15	30	1.5	1.5	0.177
1624	15	25	1.5	1.5	0.157
1625	25	25	1.5	1.5	0.197
1626	20	50	1.1	1.1	0.205
1627	50	60	4	4	1.149
1628	50	80	4	4	1.366
1629	50	100	4	4	1.583
1630	10	30	3	3	0.301

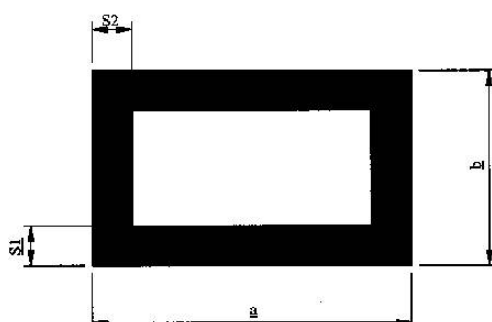

Profil No	a	b	S1	S2	Kg/mt
1800	20	15	1.2	1.2	0.212
1801	25	17	1.2	1.2	0.257
1802	40	20	1.2	1.2	0.374
1803	50	40	1.2	1.2	0.570
1804	60	15	1.15	1.15	0.453
1805	50	20	1.5	1.5	0.545
1806	95	50	1.5	1.5	1.154
1807	40	25	2	2	0.661
1808	100	50	2	2	1.582
1809	80	40	1.3	1.3	0.827
1810	75	25	1.2	1.2	0.635
1811	67	28	1	1	0.504
1812	40	30	1.2	1.2	0.440
1813	71.5	50.5	2	2	1.280
1814	90	50.5	2	2	1.480
1815	105	50	3	3	2.422
1816	30	20	1.3	1.3	0.334
1817	120	60	2	2	1.908
1819	40	20	2	2	0.607
1820	80	40	1.5	1.5	0.951
1821	60	40	1.5	1.5	0.788
1822	80	30	1.5	1.5	0.870
1823	41	26	2.5	2.5	0.840
1824	75	32	1.8	1.8	1.008
1825	30	15	1	1	0.233
1826	50	50	1.3	1.3	0.686
1827	50	40	2	2	0.932
1828	75	32	1.2	1.2	0.680
1829	40	20	1	1	0.314
1830	30	15	1.15	1.15	0.266
1831	60	60	2.5	2	1.365
1832	80	60	2.5	2	1.582

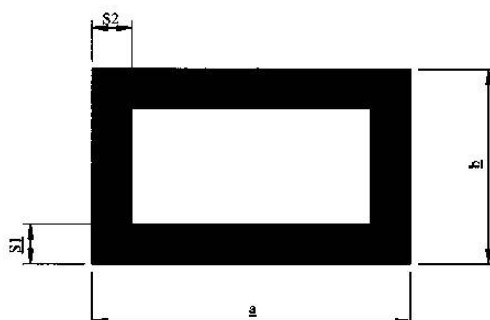

Profil No	a	b	S1	S2	Kg/mt
1833	50	28	1.1	1.1	0.452
1850	15	15	1.2	1.2	0.180
1851	20	20	1.2	1.2	0.245
1852	25	25	1.2	1.2	0.309
1853	38	38	1.1	1.1	0.440
1854	40	40	1.1	1.1	0.464
1855	35	35	2	2	0.715
1856	45	45	1.5	1.5	0.707
1857	30	30	1.2	1.2	0.375
1858	55	53	2.1	2.1	1.181
1859	50	50	2.1	2.1	1.090
1860	80	80	1.5	1.5	1.276
1861	16.4	16.4	1.2	1.2	0.198
1862	60	60	1.5	1.5	0.951
1863	40	40	2	2	0.824
1864	40	40	1	1	0.423
1865	50	40	1	1	0.477
1866	100	100	2.5	2.5	2.642
1867	40	40	2.5	2.5	1.016
1868	40	40	3	3	1.203
1869	50	50	1.2	1.2	0.635
1870	60	40	1.2	1.2	0.637
1871	60	20	1.2	1.2	0.504
1872	80	20	1.2	1.2	0.634
1873	80	80	4	4	3.295
1874	70	70	2.5	2.5	1.797
2619	75	32	1	1	0.569
3882	80	16.8	1.4	1.4	0.766
4042	40	20	1.5	1.5	0.455
4043	40	20	2	2	0.598

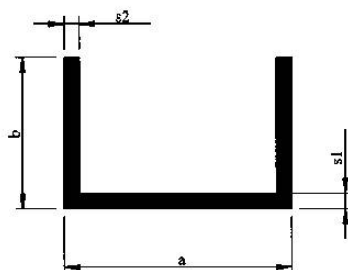

PROFIL NO	a	b	S1	S2	Kg/mt
1500	17	17	1.2	1.2	0.158
1501	19	20	1.2	1.2	0.184
1502	13	16	1	1	0.117
1503	22	22	1.2	1.2	0.207
1504	21	25	1.2	1.2	0.223
1505	18	16	1.3	1.3	0.167
1506	28	30	5	2.5	0.718
1507	19.5	28	2.8	2.8	0.530
1508	18	20	1	1	0.152
1509	17	17	2	2	0.255
1510	33	31.5	1.5	1.5	0.378
1511	20	50	3	3	0.927
1512	18	18	2	2	0.271
1513	18	13.5	2	2	0.222
1514	14	8	1.2	1.2	0.090
1515	17	17	1	1	0.132
1516	18.2	18.2	1.4	1.4	0.197
1517	18.2	17.8	1.1	1.1	0.154
1518	13.5	14	1.2	1.2	0.127
1519	11.8	14	1.2	1.2	0.121
1520	15.6	8	1.2	1.2	0.095
1521	17	16	1	1	0.127
3279	18	18.2	1.5	1.5	0.209
3333	10	20	1.3	1.3	0.167
3338	10	11	1.3	1.3	0.104
3391	80	80	2.5	2.5	1.583
4030	120	30	2	2	0.954

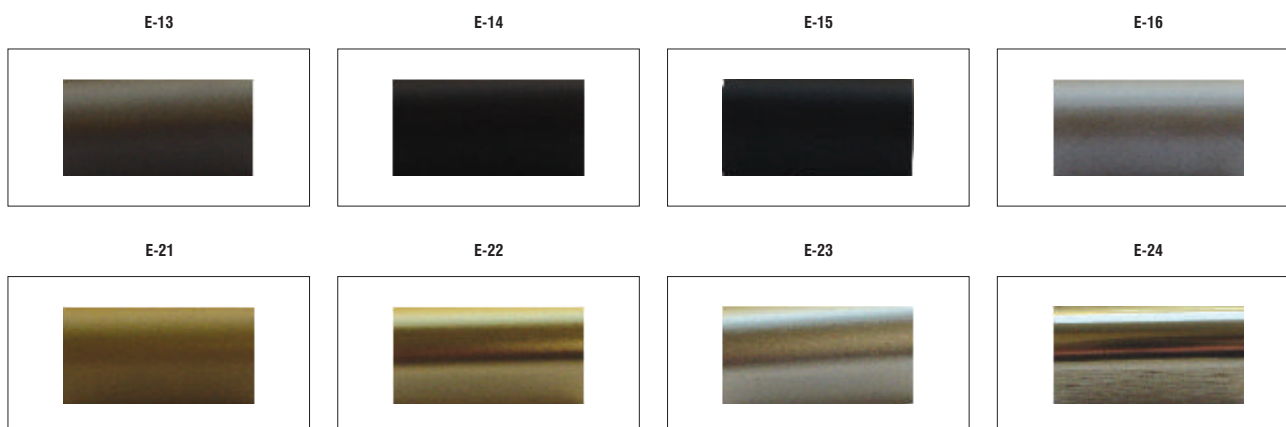
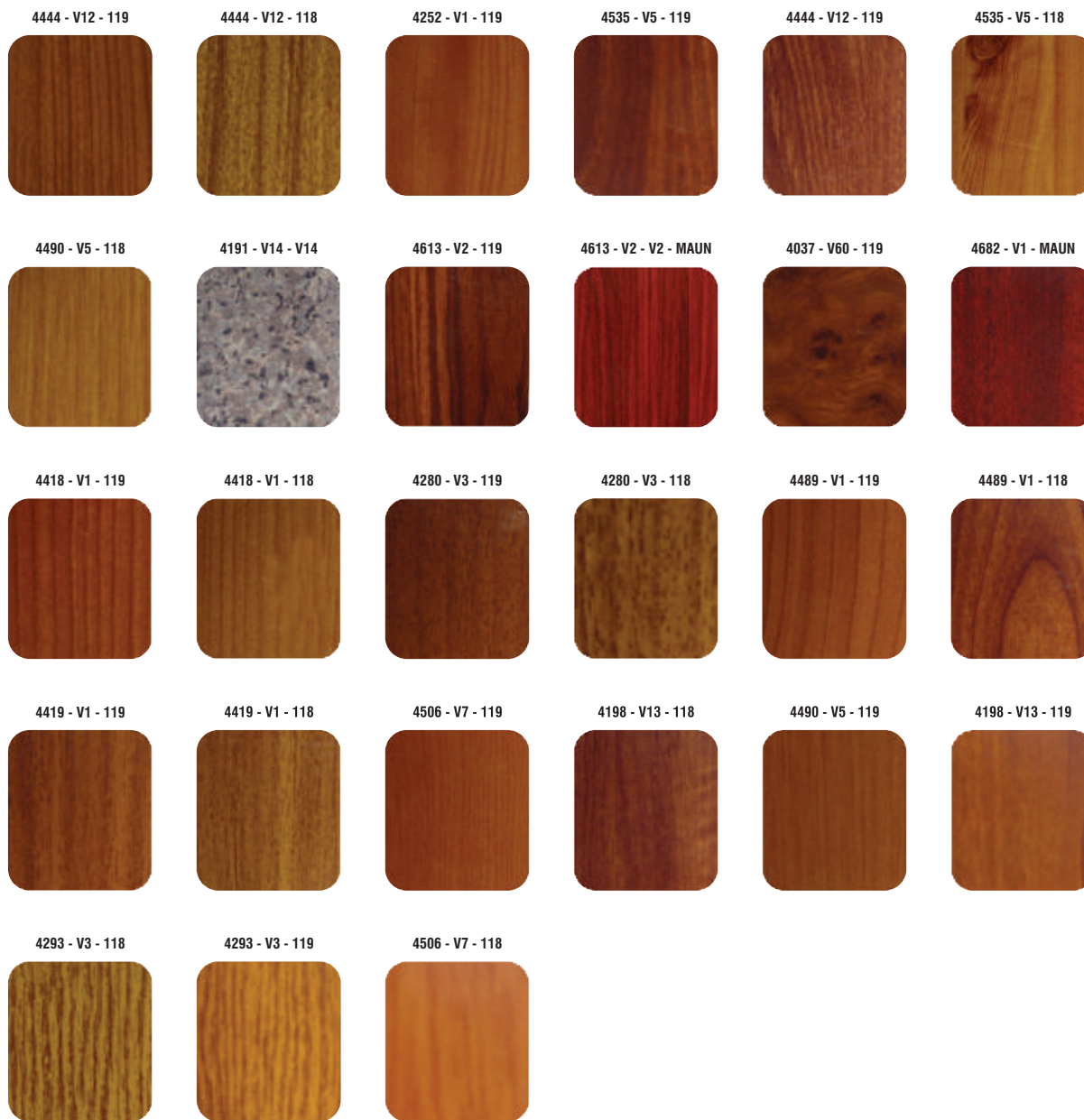

MAT / MAT

KIRMIZI



NATURAL

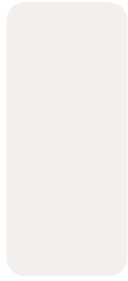

701



C 33



703



C 34



709



PARLAK / GLOSSY





* XRD series is a category entry used for other alloys

Wrought aluminium alloy composition limits (% weight)

Alloy	Si	Fe	Cu	Mn	Mg	Zn	V	Ti	Pb	Li	Pb	Zr	Limits**		Al
													Each	Total	
1050	0.25	0.25	0.05	0.02	0.02	0.02	0.01	0.05	0.02	0.02	0.02	0.02	0.02	0.02	99.5 min
1100	0.05 Fe+Pb		0.05-0.20	0.05			0.10							0.05	99.5 min
2014	0.50-1.0	0.7	3.0-6.0	0.10-0.2	0.20-0.8	0.10	0.25		0.15					0.05	0.15 remainder
2024	0.10	0.50	2.0-4.5	0.20-0.5	1.2-1.8	0.10	0.20		0.15					0.05	0.15 remainder
2219	0.2	0.20	0.0-0.5	0.20-0.40	0.02		0.10	0.05-0.10	0.02-0.10			0.10-0.25		0.05	0.15 remainder
3003	0.5	0.7	0.05-0.20	1.0-1.5			0.10							0.05	0.15 remainder
5005	0.50	0.7	0.25	1.0-1.5	0.8-1.3		0.25							0.05	0.15 remainder
5102	0.40	0.7	0.10	0.05-0.40			0.20		0.10					0.05	0.15 remainder
4043	4.0-6.0	0.60	0.20	0.05	0.05		0.10		0.20					0.05	0.15 remainder
5052	0.25	0.40	0.10	0.10	2.0-2.5	0.15-0.35	0.10							0.05	0.15 remainder
5053	0.40	0.40	0.10	0.10-0.5	1.0-1.5	0.05-0.25	0.25		0.15					0.05	0.15 remainder
5056	0.40	0.50	0.10	0.20-0.7	2.5-4.0	0.05-0.20	0.20		0.15					0.05	0.15 remainder
5154	0.25	0.40	0.10	0.10	2.10-2.90	0.15-0.25	0.20		0.20					0.05	0.15 remainder
5356	0.25	0.40	0.10	0.10	4.50-5.50	0.05-0.20	0.10		0.05-0.20					0.05	0.15 remainder
5454	0.25	0.40	0.10	0.50-1.0	2.0-3.0	0.05-0.20	0.25		0.20					0.05	0.15 remainder
5456	0.25	0.40	0.10	0.50-1.0	4.7-5.2	0.05-0.20	0.20		0.20					0.05	0.15 remainder
5754	0.40	0.40	0.10	0.20	2.0-3.0	0.20	0.20		0.15					0.05	0.15 remainder
6061	0.5-0.8	0.25	0.10	0.10	0.40-0.6	0.10	0.10		0.10					0.05	0.15 remainder
6063	0.50-0.9	0.25	0.20	0.50	0.40-0.7	0.20	0.20		0.10					0.05	0.15 remainder
6069	0.20-0.6	0.10-0.30	0.10	0.10	0.35-0.6	0.05	0.15		0.10					0.05	0.15 remainder
6081	0.40-0.8	0.7	0.10-0.40	0.15	0.0-1.2	0.04-0.20	0.20		0.15					0.05	0.15 remainder
6101	0.20-0.5	0.25	0.10	0.10	0.45-0.9	0.10	0.10		0.10					0.05	0.15 remainder
6066	0.5-1.8	0.60	0.7-1.2	0.5-1.1	0.8-1.4	0.40	0.25		0.20					0.05	0.15 remainder
6060	1.0-1.7	0.60	0.10-0.40	0.40-1.0	0.60-1.2	0.10	0.20		0.15					0.05	0.15 remainder
6102	0.7-1.3	0.60	0.10	0.10-0.5	0.60-1.2	0.25	0.20		0.10					0.05	0.15 remainder
6105	0.5-1.0	0.25	0.10	0.10	0.45-0.8	0.10	0.10		0.10					0.05	0.15 remainder
6102	0.40-0.8	0.60	0.20	0.10	0.7-1.1	0.10	0.20		0.10					0.05	0.15 remainder
6202	0.40-0.8	0.7	0.10-0.40	0.15	0.0-1.2	0.04-0.14	0.20		0.15	0.40-0.7	0.40-0.7			0.05	0.15 remainder
6351	0.7-1.3	0.60	0.10	0.10-0.5	0.40-0.8		0.20		0.20					0.05	0.15 remainder
6463	0.20-0.6	0.15	0.20	0.05	0.45-0.9		0.05							0.05	0.15 remainder
7050	0.25	0.40	0.10	0.20-0.70	1.0-1.8	0.05-0.20	4.0-5.0		0.01-0.05			0.05-0.20		0.05	0.15 remainder
7052	0.50	0.60	0.50-1.00	0.10-0.40	2.65-3.70	0.10-0.35	4.30-5.70		0.20					0.05	0.15 remainder
7072	0.7-8.0 Fe		0.10	0.10	0.10		0.8-1.3							0.05	0.15 remainder
7075	0.40	0.50	1.2-2.0	0.20	2.1-2.9	0.10-0.25	5.1-6.1		0.20					0.05	0.15 remainder
7079	0.3	0.40	0.40-0.80	0.10-0.30	2.9-3.7	0.10-0.25	3.0-4.0		0.10					0.05	0.15 remainder
7116	0.15	0.20	0.50-1.1	0.05	0.8-1.4		4.2-6.2	0.05	0.05		0.03			0.05	0.15 remainder
7129	0.15	0.20	0.50-0.9	0.10	1.3-2.0	0.10	4.2-6.2	0.05	0.05		0.03			0.05	0.15 remainder
7170	0.40	0.50	1.0-2.4	0.20	2.4-3.1	0.10-0.25	6.2-7.0		0.20					0.05	0.15 remainder

**Manganese plus chromium must be between 0.17-0.50%
 †† This column lists the limits that apply to all elements, whether a table column exists for them or not, for which no other limits are specified.

- Heat treated to produce stable tempers
- T1
- Cooled from hot working and naturally aged (at room temperature)
- T2
- Cooled from hot working, cold-worked, and naturally aged
- T3
- Solution heat treated and cold worked
- T4
- Solution heat treated and naturally aged
- T5
- Cooled from hot working and artificially aged (at elevated temperature)
- T51
- Stress relieved by stretching
- T510
- No further straightening after stretching
- T511
- Minor straightening after stretching
- T52
- Stress relieved by thermal treatment
- T6
- Solution heat treated and artificially aged
- T7
- Solution heat treated and stabilized
- T8
- Solution heat treated, cold worked, and artificially aged
- T9
- Solution heat treated, artificially aged, and cold worked
- T10
- Cooled from hot working, cold-worked, and artificially aged

Solution heat treated only.

Note: -W is a relatively soft intermediary designation that applies after heat treat and before aging is completed. The -W condition can be extended at extremely low temperatures but not indefinitely and depending on the material will typically last no longer than 15 minutes at ambient temperatures.

A) [edit] Wrought alloys

The International Alloy Designation System is the most widely accepted naming scheme for wrought alloys. Each alloy is given a four-digit number, where the first digit indicates the major alloying elements.

1000 series are essentially *pure aluminium* with a minimum 99% aluminium content by weight and can be work hardened.

2000 series are alloyed with *copper*, can be precipitation hardened to strengths comparable to steel. Formerly referred to as duralumin, they were once the most common aerospace alloys, but were susceptible to stress corrosion cracking and are increasingly replaced by 7000 series in new designs.



Alucomplast

C 60 Profilu

C 60 Profiles

C 60 Profile

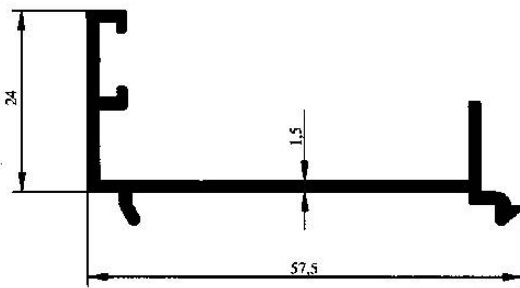
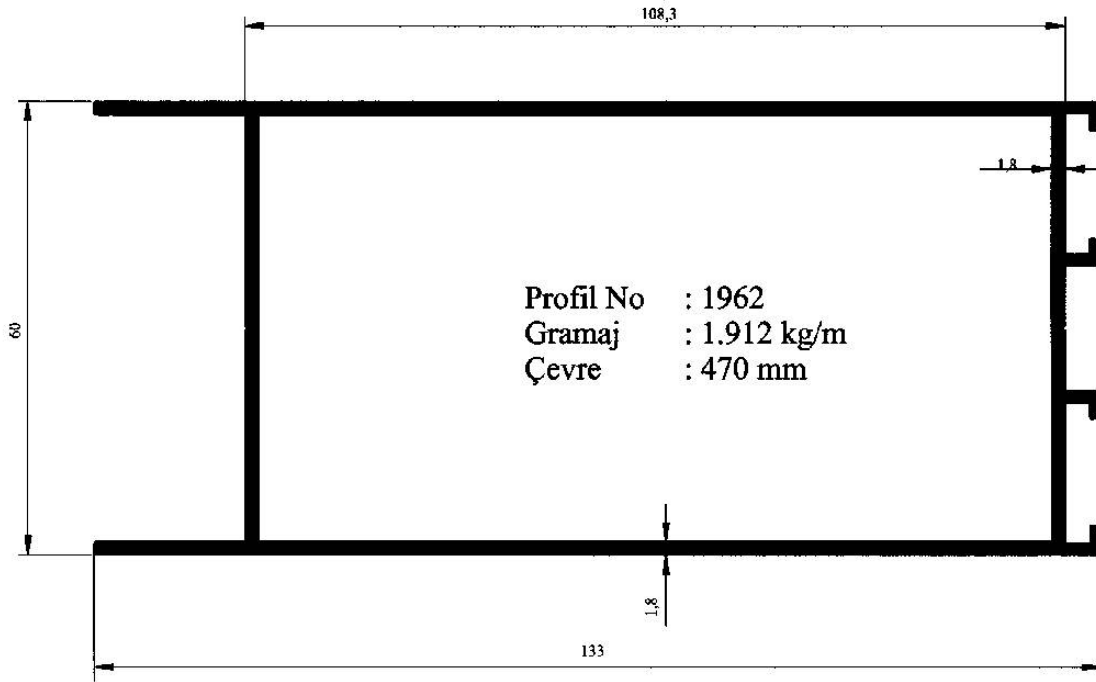
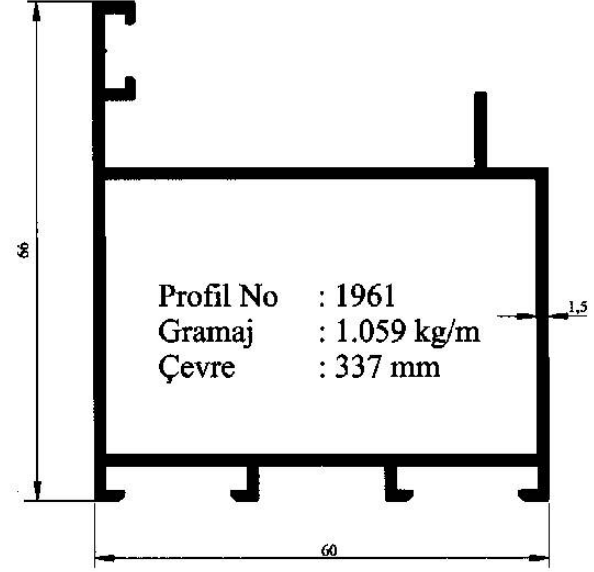
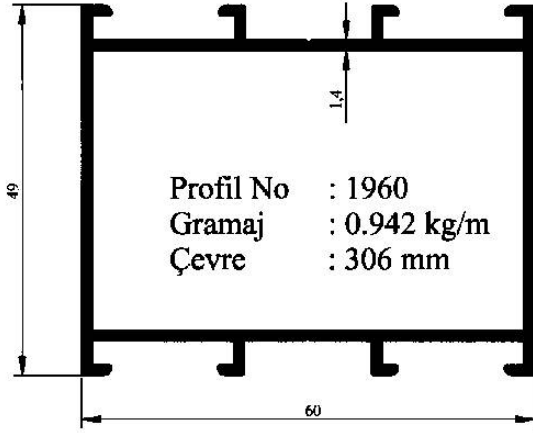

Profil No : 1963
Gramaj : 0.442 kg/m
Çevre : 219 mm

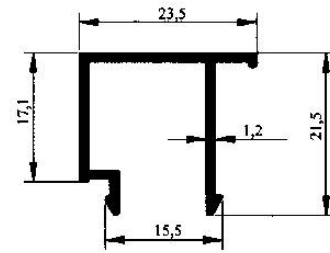

Profil No : 1964
Gramaj : 0.229 kg/m
Çevre : 140 mm

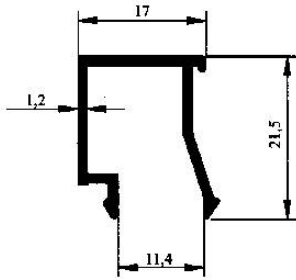

Profil No : 1965
Gramaj : 0.208 kg/m
Çevre : 127 mm

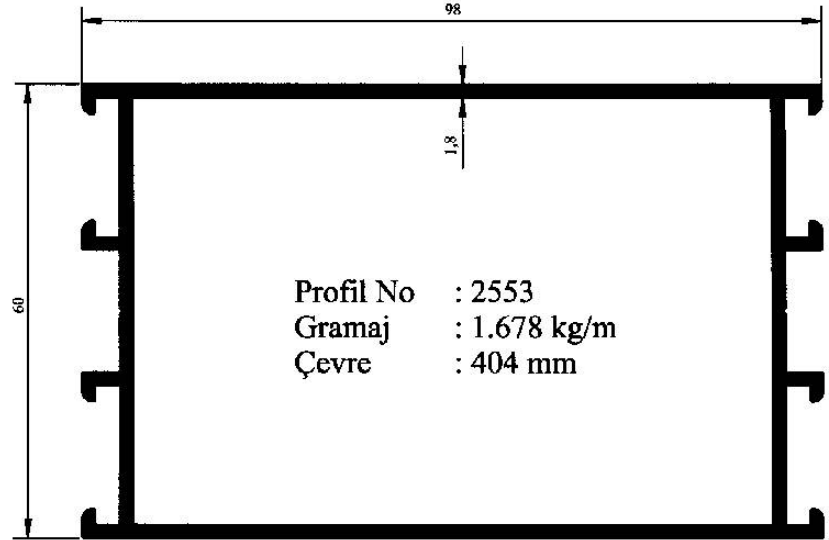

Profil No : 2553
Gramaj : 1.678 kg/m
Çevre : 404 mm

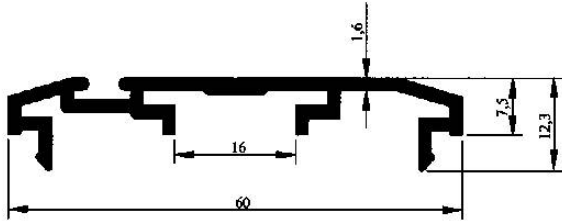

Profil No : 2570
Gramaj : 0.499 kg/m
Çevre : 229 mm

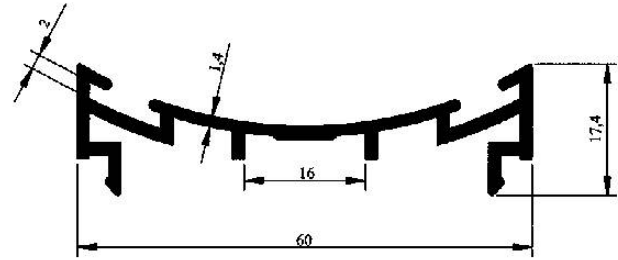

Profil No : 2571
Gramaj : 0.530 kg/m
Çevre : 225 mm

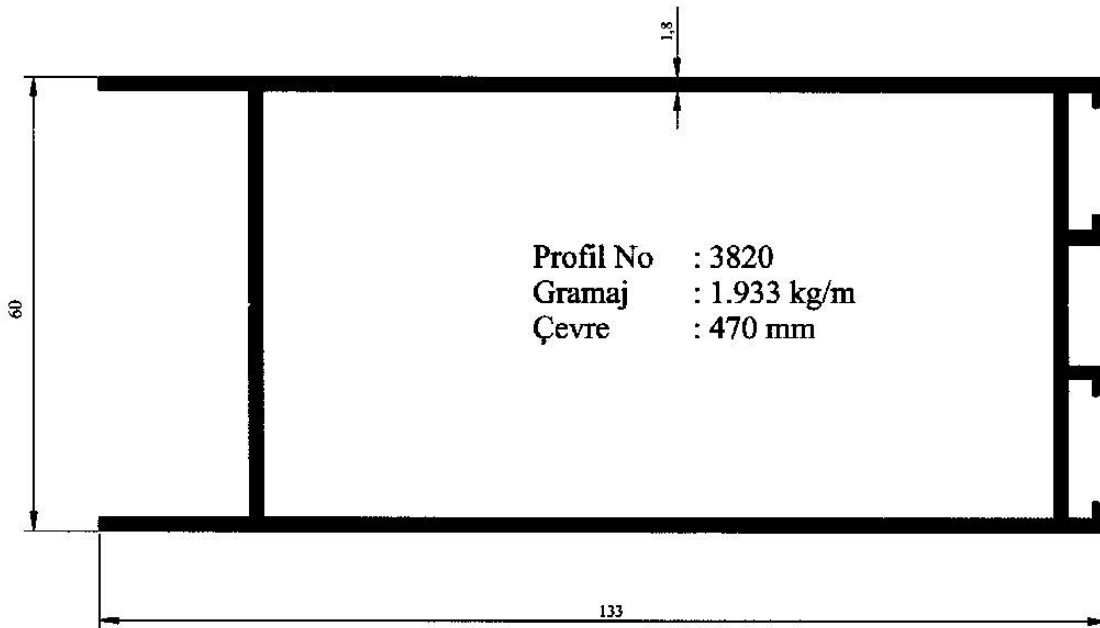

Profil No : 3820
Gramaj : 1.933 kg/m
Çevre : 470 mm

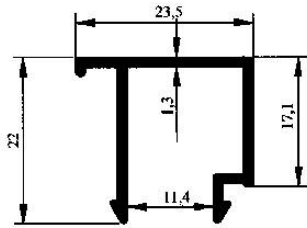
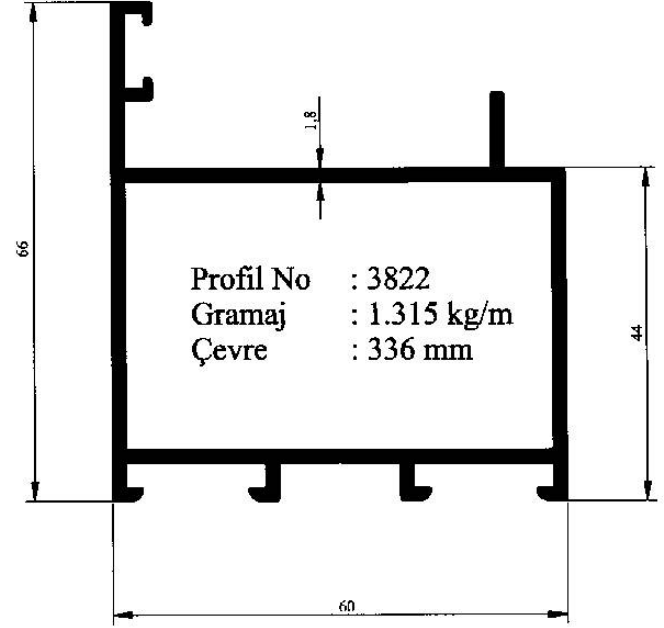
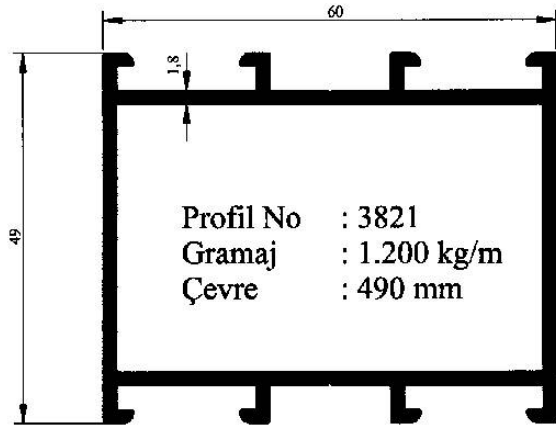

Profil No : 3823
Gramaj : 0.252 kg/m
Çevre : 143 mm

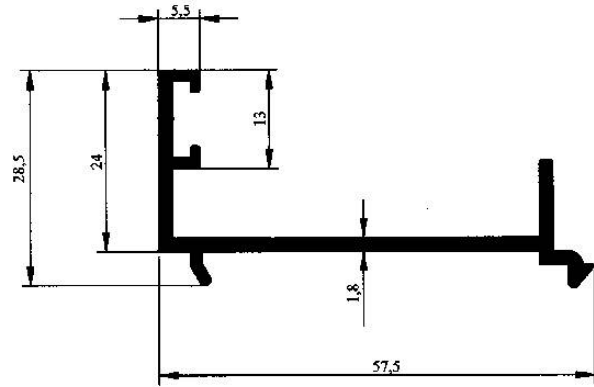

Profil No : 3824
Gramaj : 0.516 kg/m
Çevre : 219 mm

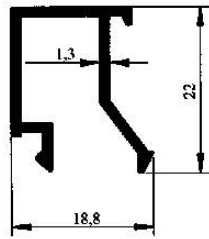

Profil No : 3899
Gramaj : 0.230 kg/m
Çevre : 132 mm



Alucomplast

Zasklívání lodžii
Balcony Glazing Profiles
Balkonverglasungen Profile

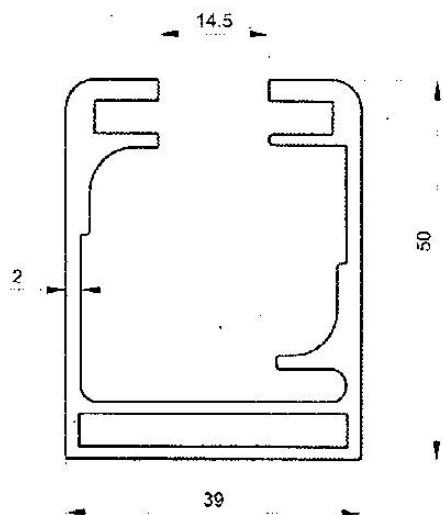

1.282 kg/m
4700

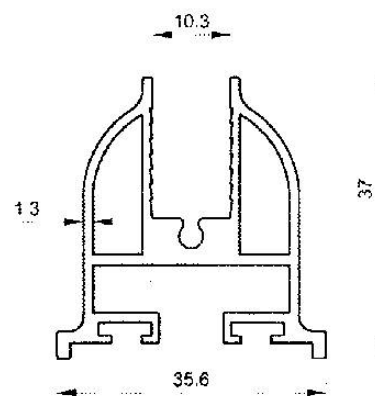

0.748 kg/m
4701

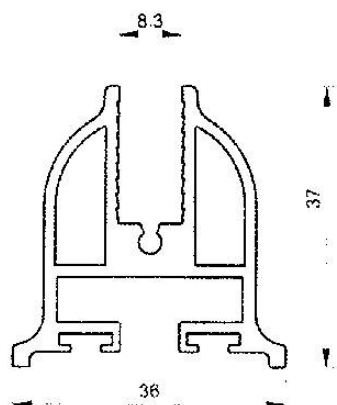

0.870 kg/m
4702

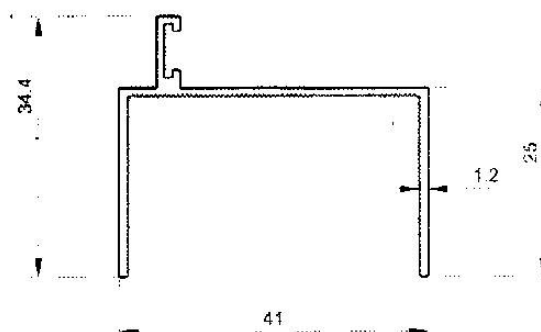

0,317 Kg./m
4703

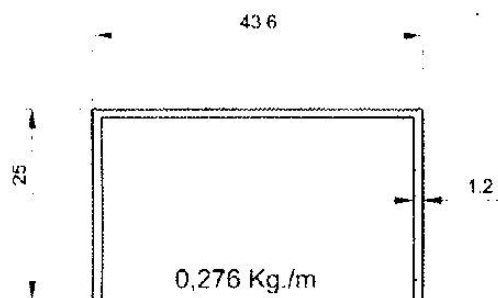

0,276 Kg./m
4704

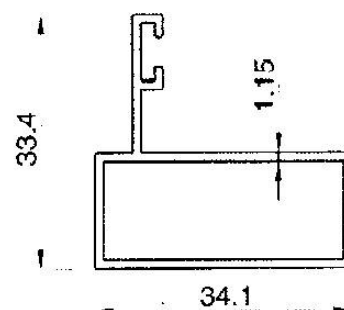

0,375 Kg./m
4705

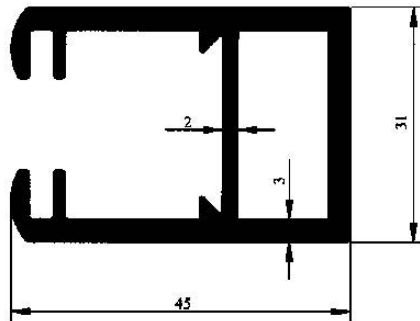

Profil No : 1901
 Gramaj : 1.212 kg/m
 Çevre : 257 mm

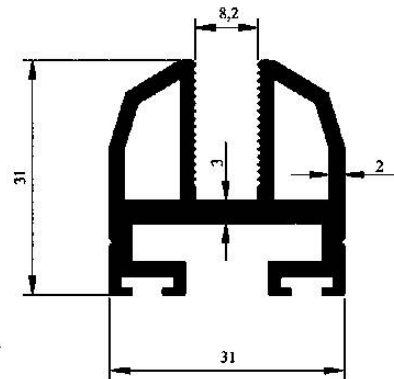

Profil No : 1902
 Gramaj : 0.904 kg/m
 Çevre : 231 mm

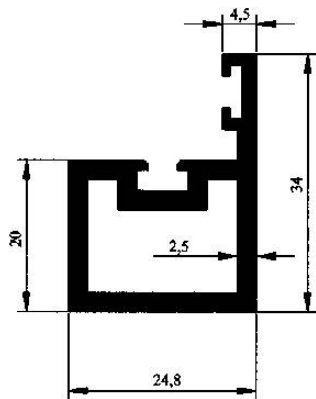

Profil No : 1903
 Gramaj : 0.713 kg/m
 Çevre : 145 mm



Alucomplast

Hliníkové zábradlí
Railing Profiles

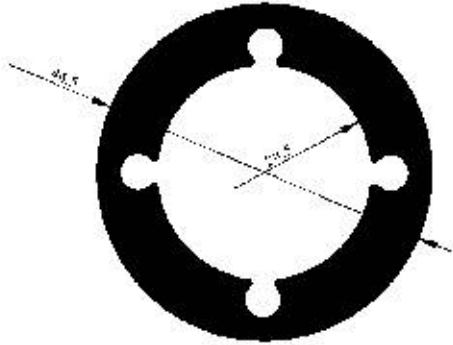

Profil No : 2225
Gramaj : 2.278 kg/m
Çevre : 140 mm

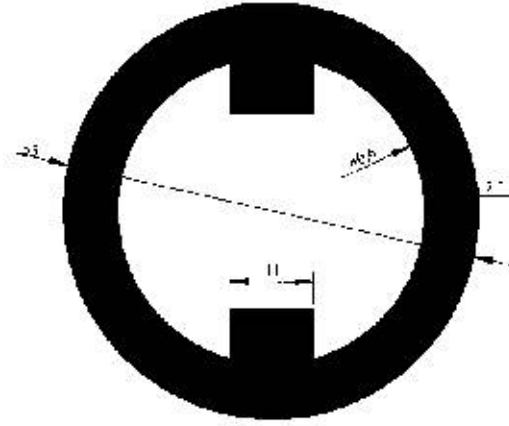

Profil No : 2226
Gramaj : 3.354 kg/m
Çevre : 173 mm

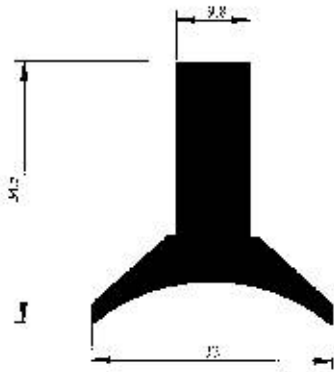

Profil No : 2227
Gramaj : 1.046 kg/m
Çevre : 125 mm

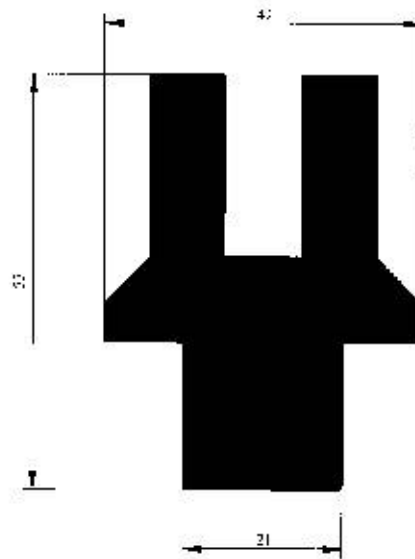

Profil No : 2228
Gramaj : 3.592 kg/m
Çevre : 234 mm

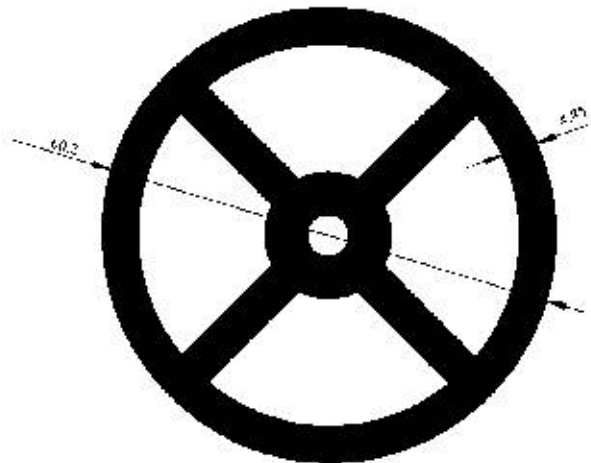

Profil No : 2230
Gramaj : 3.740 kg/m
Çevre : 189 mm

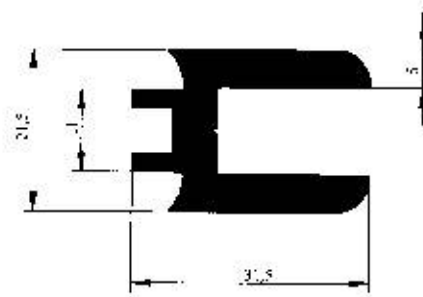

Profil No : 2229
Gramaj : 0.917 kg/m
Çevre : 157 mm

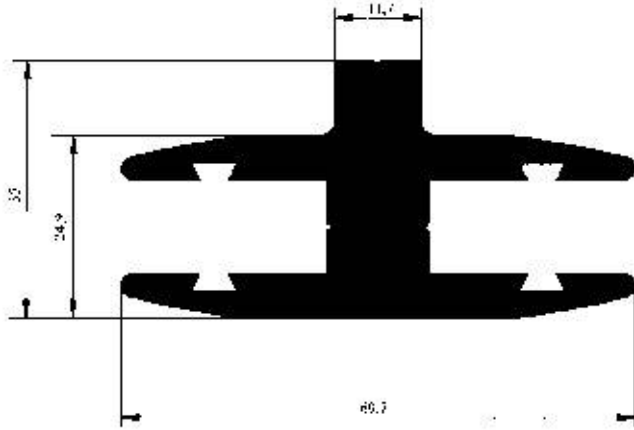

Profil No : 2239
Gramaj : 2.715 kg/m
Çevre : 333 mm

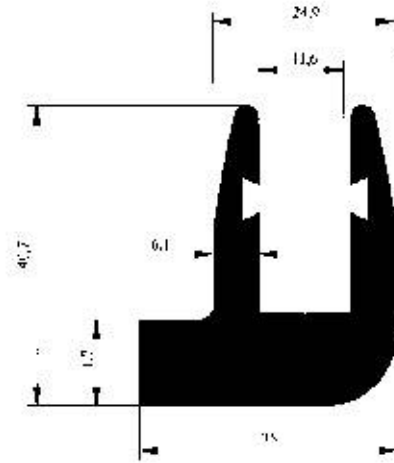

Profil No : 2245
Gramaj : 1.854 kg/m
Çevre : 209 mm

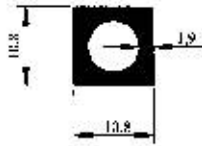

Profil No : 2256
Gramaj : 0.212 kg/m
Çevre : 43 mm

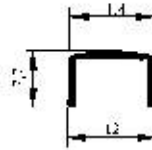

Profil No : 2989
Gramaj : 0.059 kg/m
Çevre : 50 mm

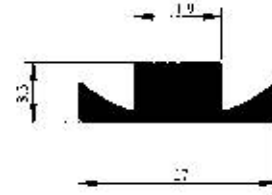

Profil No : 2273
Gramaj : 0.403 kg/m
Çevre : 80 mm

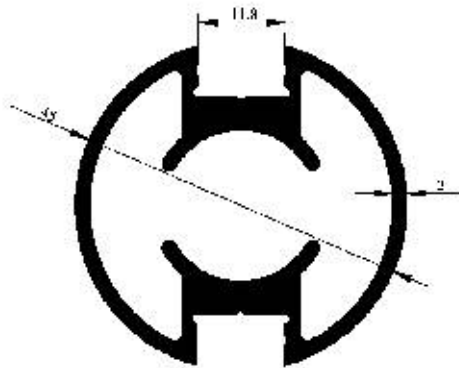

Profil No : 2913
Gramaj : 1.261 kg/m
Çevre : 374 mm

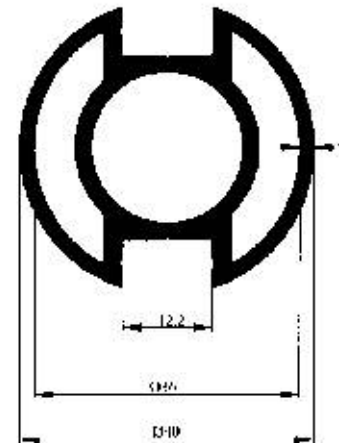

Profil No : 3061
Gramaj : 1.151 kg/m
Çevre : 151 mm

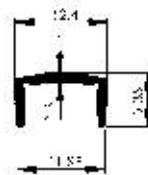

Profil No : 3062
Gramaj : 0.068 kg/m
Çevre : 48 mm

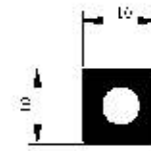
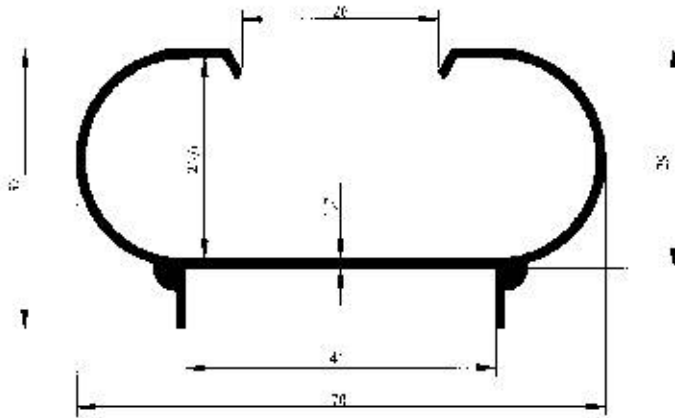

Profil No : 2938
 Gramaj : 0.214 kg/m
 Çevre : 56 mm

Profil No : 3610
 Gramaj : 0.569 kg/m
 Çevre : 324 mm

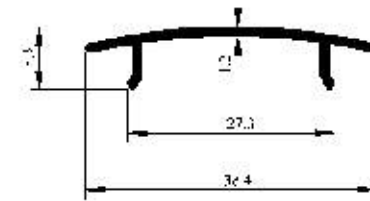
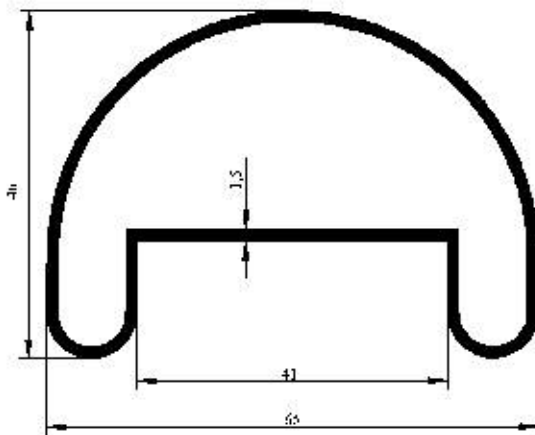

Profil No : 3611
 Gramaj : 0.164 kg/m
 Çevre : 102 mm

Profil No : 3684
 Gramaj : 0.857 kg/m
 Çevre : 215 mm

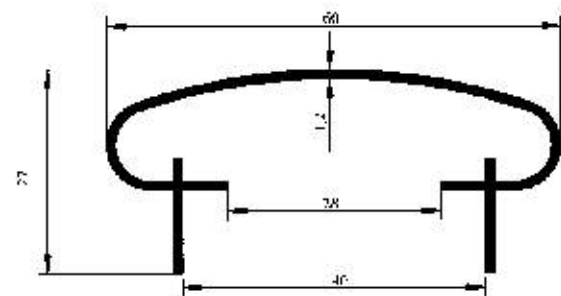
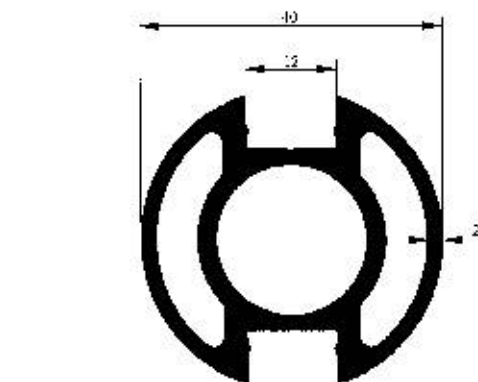

Profil No : 3688
 Gramaj : 0.425 kg/m
 Çevre : 264 mm

Profil No : 3993
 Gramaj : 1,225 kg/m
 Çevre : 155 mm

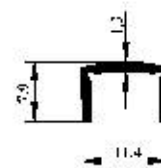

Profil No : 3994
 Gramaj : 0.076 kg/m
 Çevre : 51 mm

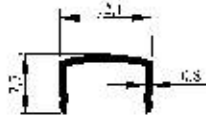

Profil No : 4038
Gramaj : 0.054 kg/m
Çevre : 51 mm

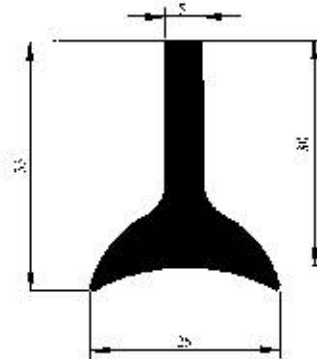

Profil No : 4063
Gramaj : 0.734 kg/m
Çevre : 104 mm

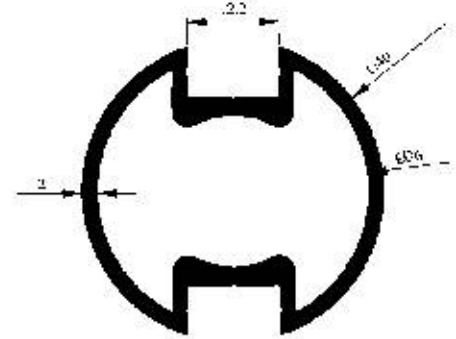

Profil No : 4071
Gramaj : 0.866 kg/m
Çevre : 152 mm

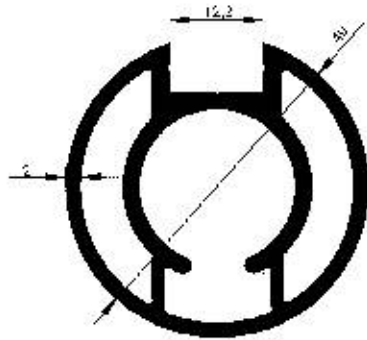

Profil No : 4082
Gramaj : 1.125 kg/m
Çevre : 139 mm

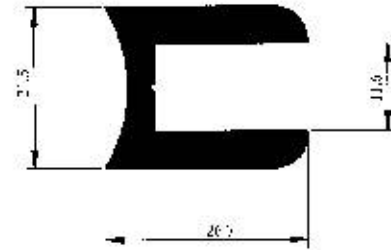

Profil No : 4090
Gramaj : 0.780 kg/m
Çevre : 134 mm

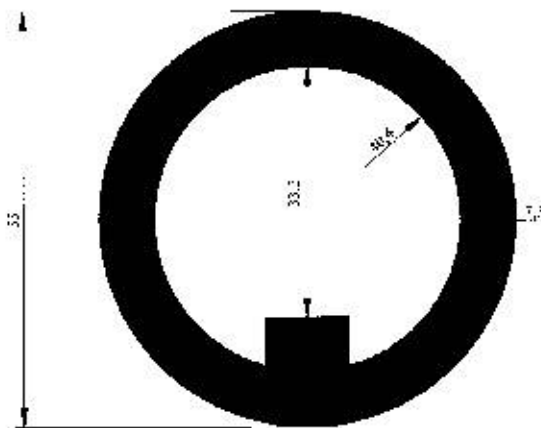

Profil No : 4101
Gramaj : 3.172 kg/m
Çevre : 173 mm

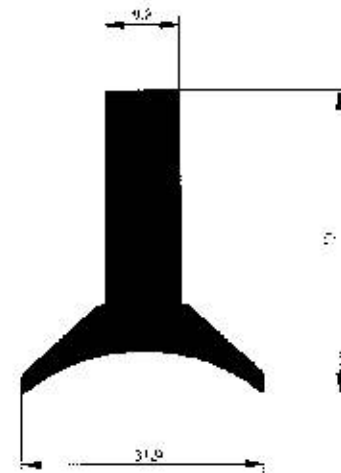

Profil No : 4376
Gramaj : 1.193 kg/m
Çevre : 136 mm

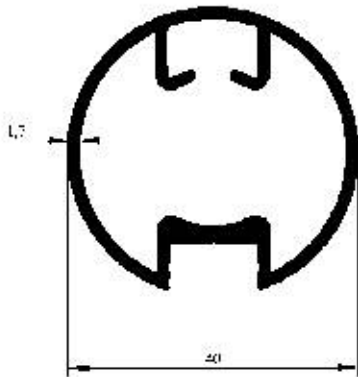

Profil No : 4473
Gramaj : 0.775 kg/m
Çevre : 139 mm

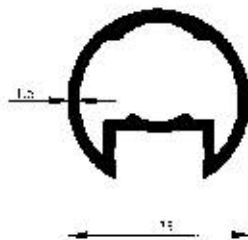

Profil No : 4504
Gramaj : 0.371 kg/m
Çevre : 91 mm

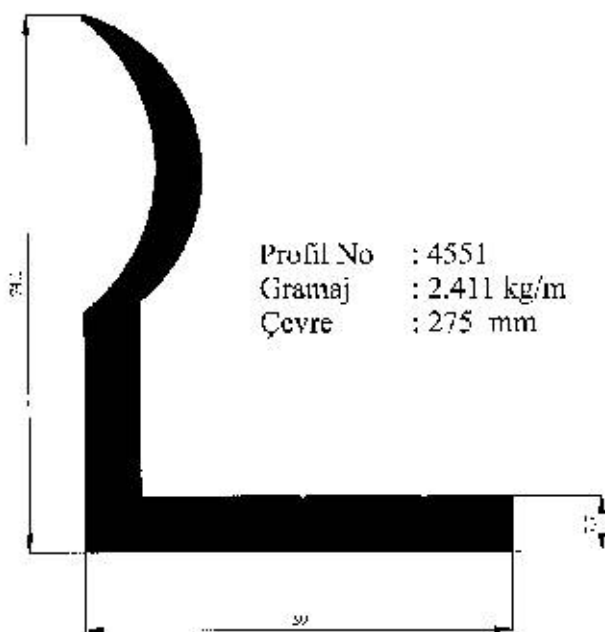

Profil No : 4551
Gramaj : 2.411 kg/m
Çevre : 275 mm

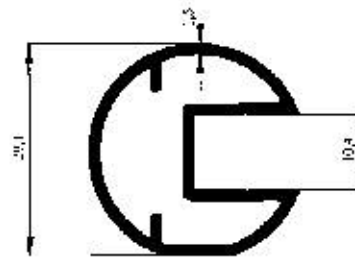

Profil No : 4486
Gramaj : 0.505 kg/m
Çevre : 123 mm

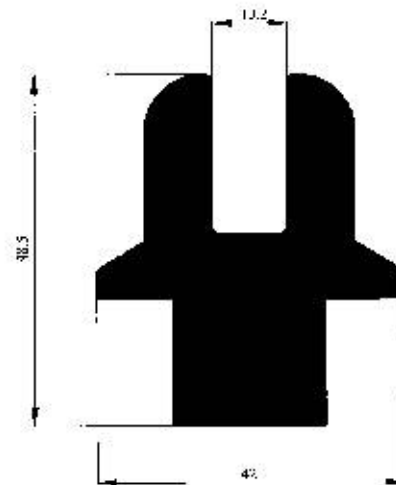

Profil No : 4510
Gramaj : 2.961 kg/m
Çevre : 210 mm

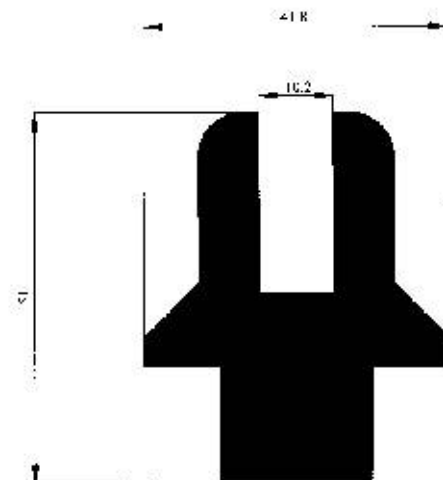

Profil No : 4553
Gramaj : 3.026 kg/m
Çevre : 221 mm

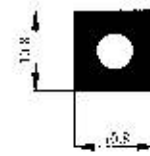
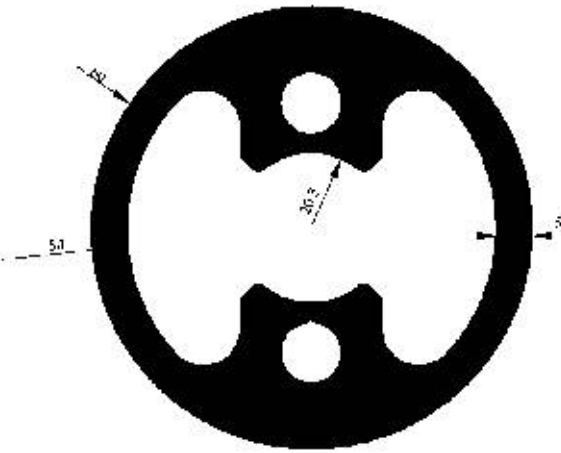

Profil No : 4603
Gramaj : 0.263 kg/m
Çevre : 43 mm

Profil No : 4561
Gramaj : 3.903 kg/m
Çevre : 188 mm

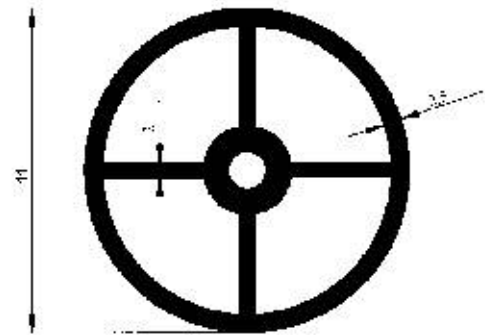
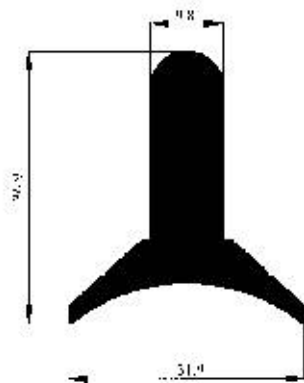

Profil No : 4610
Gramaj : 1.431 kg/m
Çevre : 138 mm

Profil No : 4613
Gramaj : 1.080 kg/m
Çevre : 125 mm

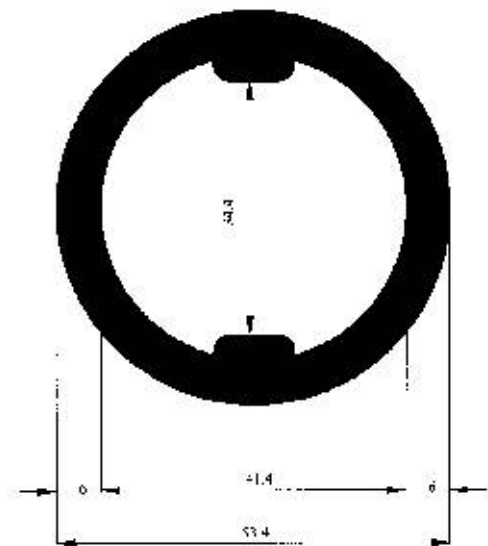
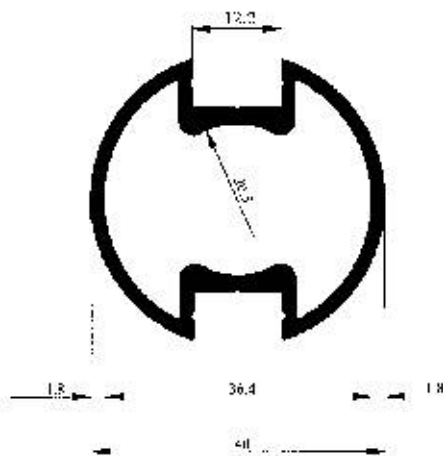

Profil No : 4614
Gramaj : 2.604 kg/m
Çevre : 168 mm

Profil No : 4694
Gramaj : 0.799 kg/m
Çevre : 152 mm

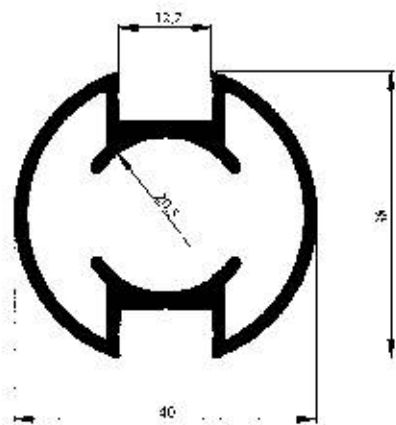

Profil No : 4716
Gramaj : 0.851 kg/m
Çevre : 152 mm

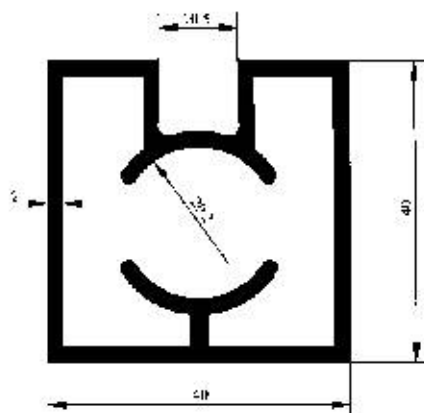

Profil No : 4725
Gramaj : 1.153 kg/m
Çevre : 178 mm

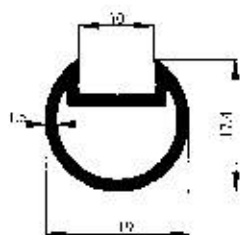

Profil No : 4728
Gramaj : 0.257 kg/m
Çevre : 68 mm

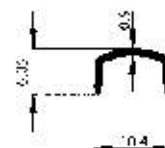

Profil No : 4729
Gramaj : 0.043 kg/m
Çevre : 39 mm

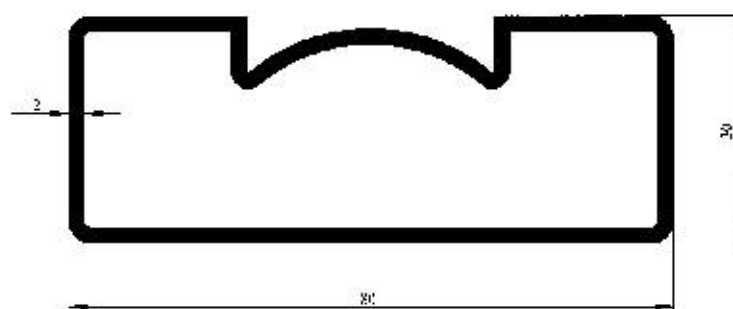

Profil No : 4726
Gramaj : 1.221 kg/m
Çevre : 232 mm

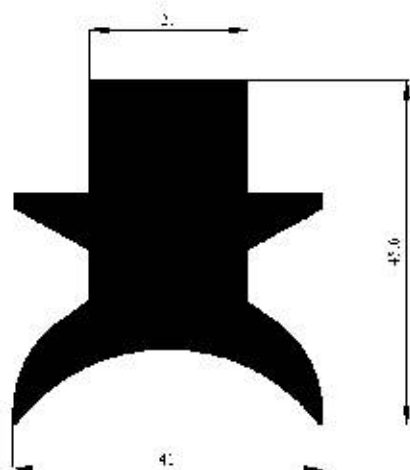

Profil No : 4736
Gramaj : 2.739 kg/m
Çevre : 198 mm

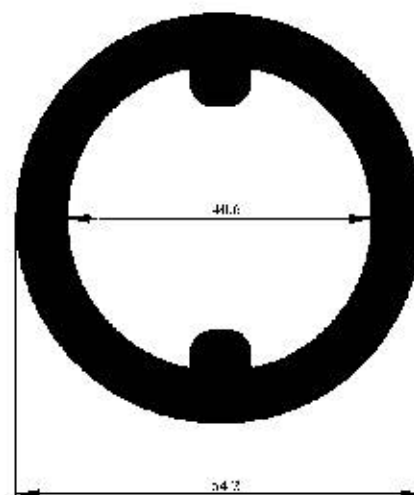

Profil No : 4738
Gramaj : 2.954 kg/m
Çevre : 170 mm





Alucomplast

Okení Parapety
Windows Sills

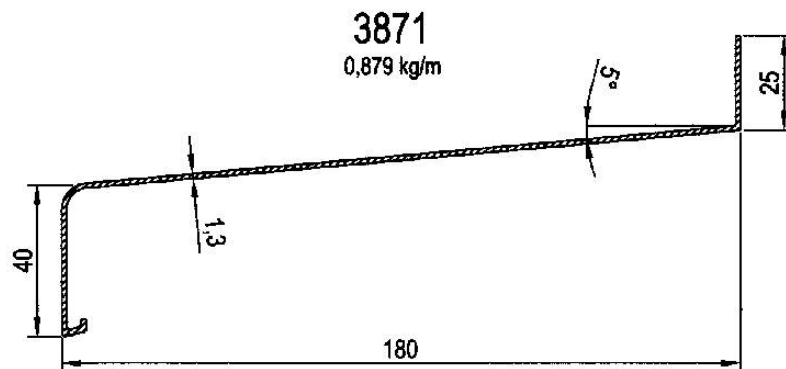
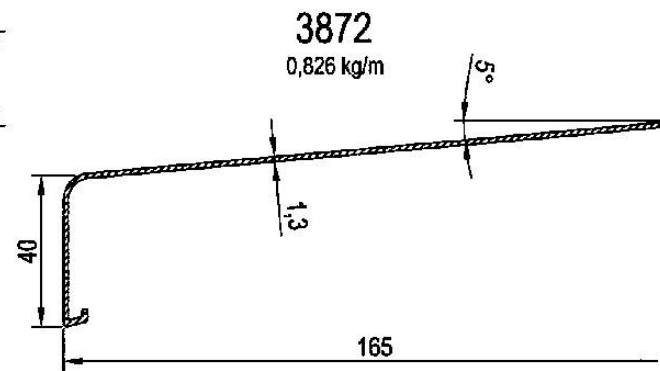
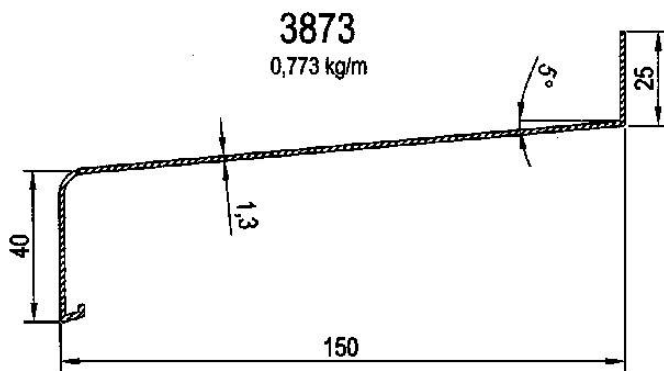
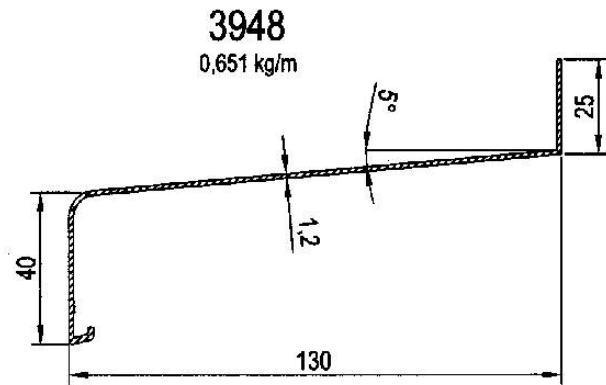
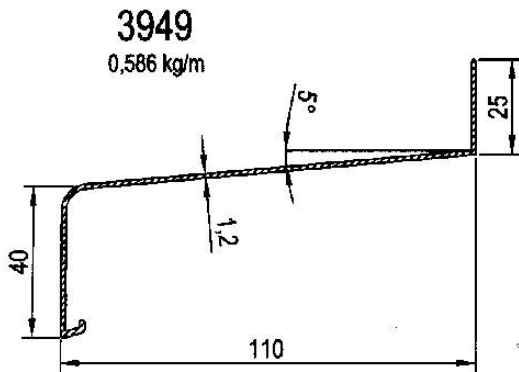
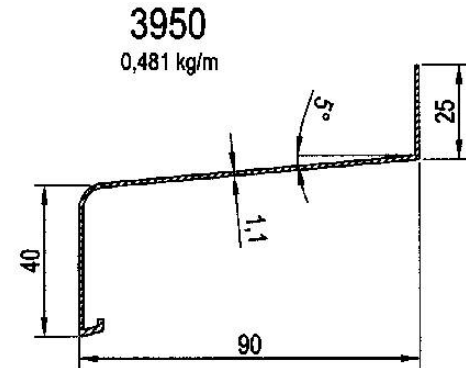
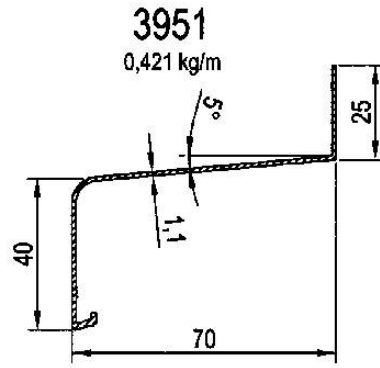
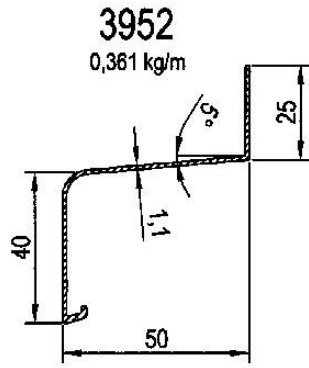

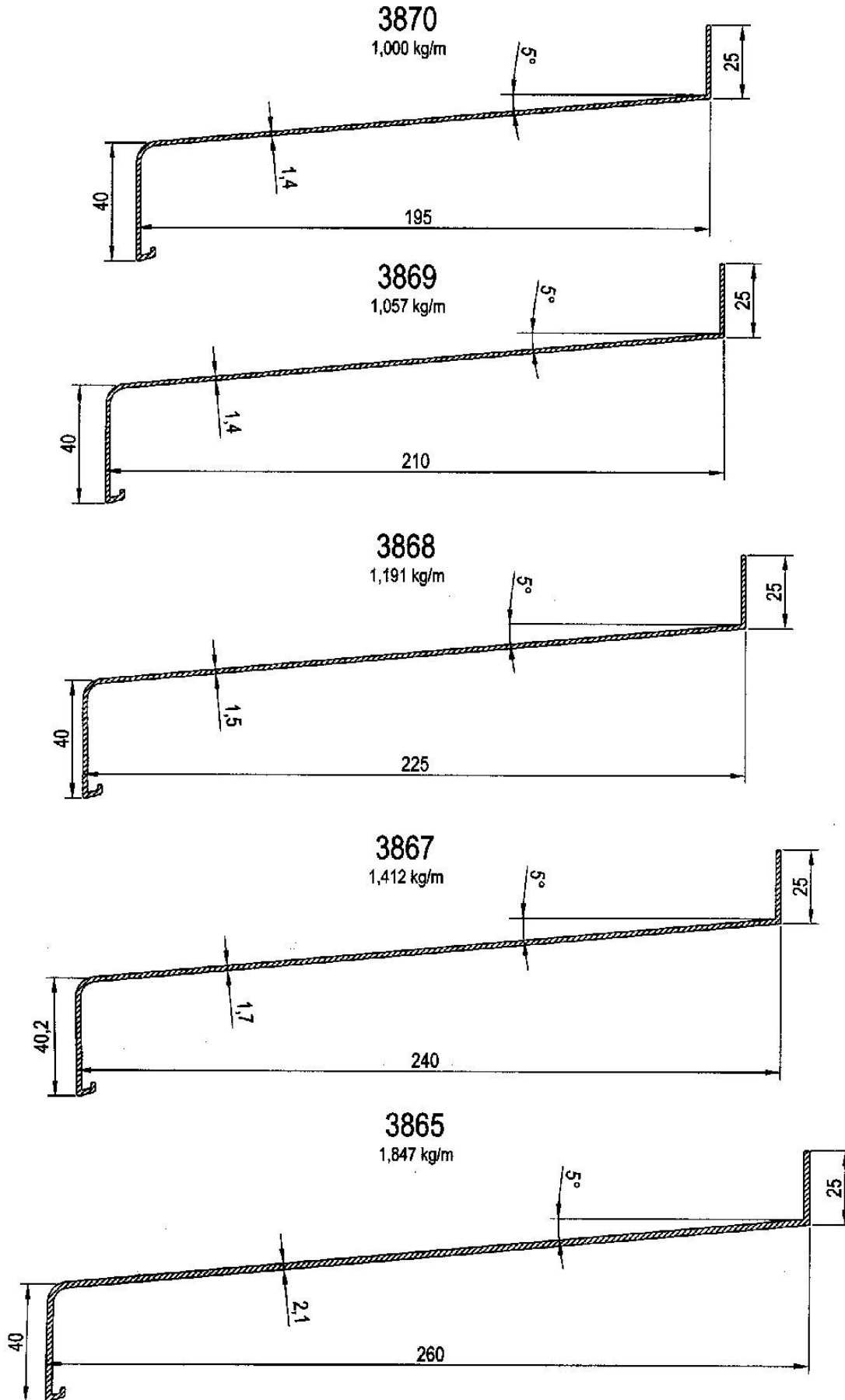

3866
1,961 kg/m

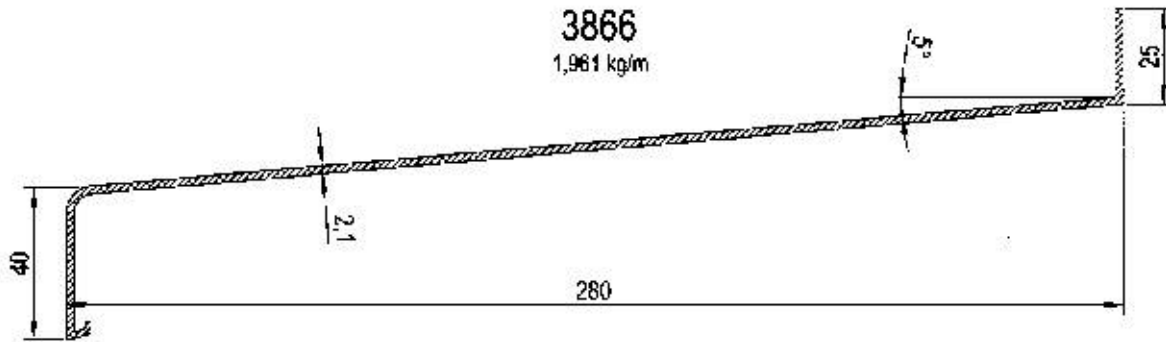

3786
2,171 kg/m

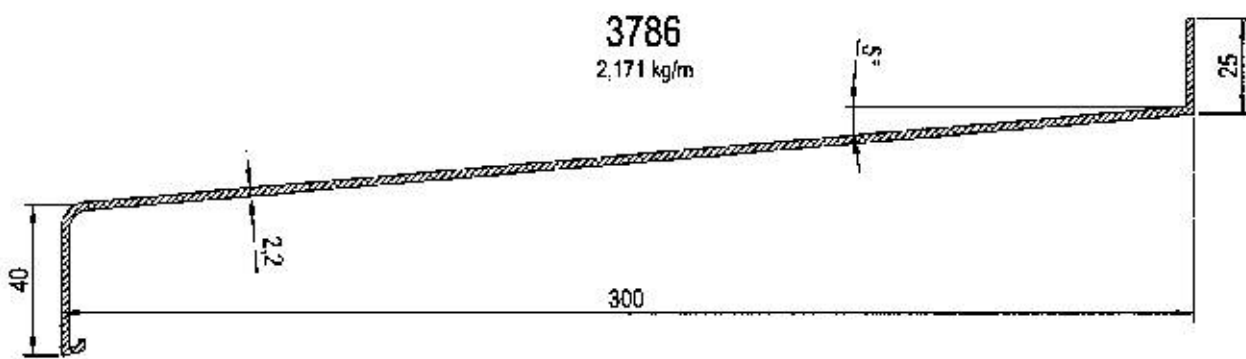

3787
2,291 kg/m

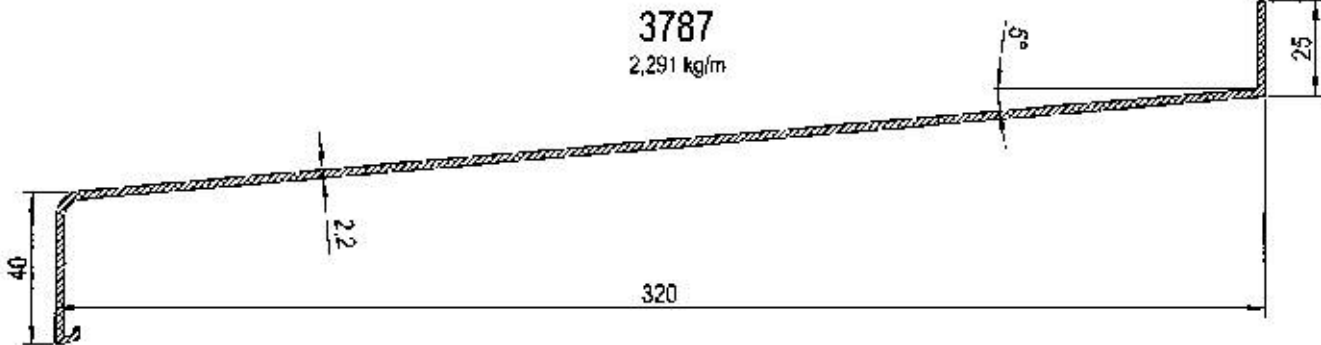

3788
2,411 kg/m

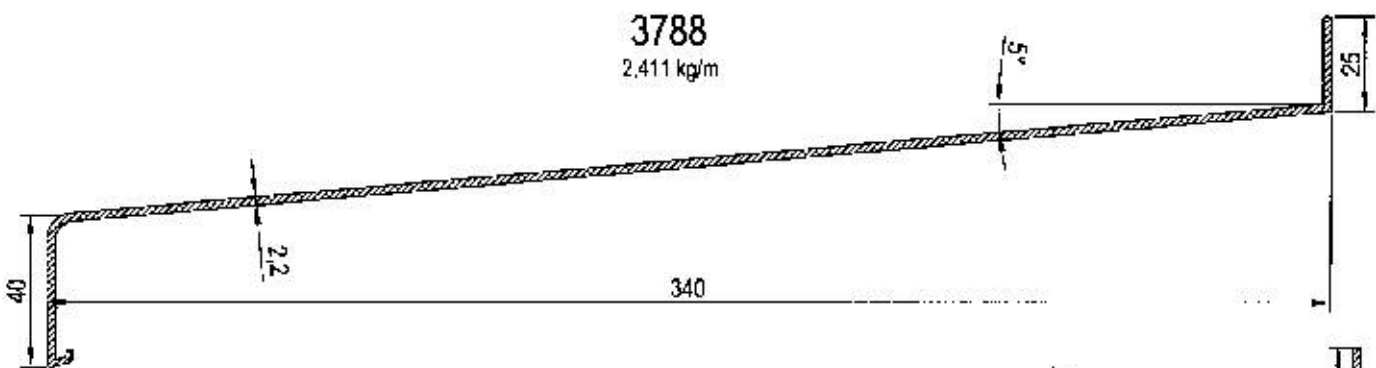

3789
2,842 kg/m

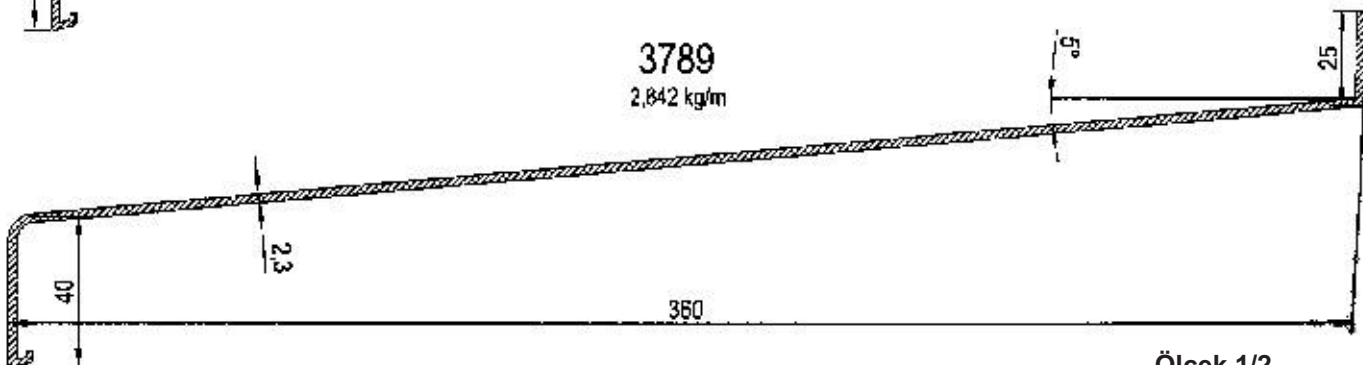

Ölçek 1/2

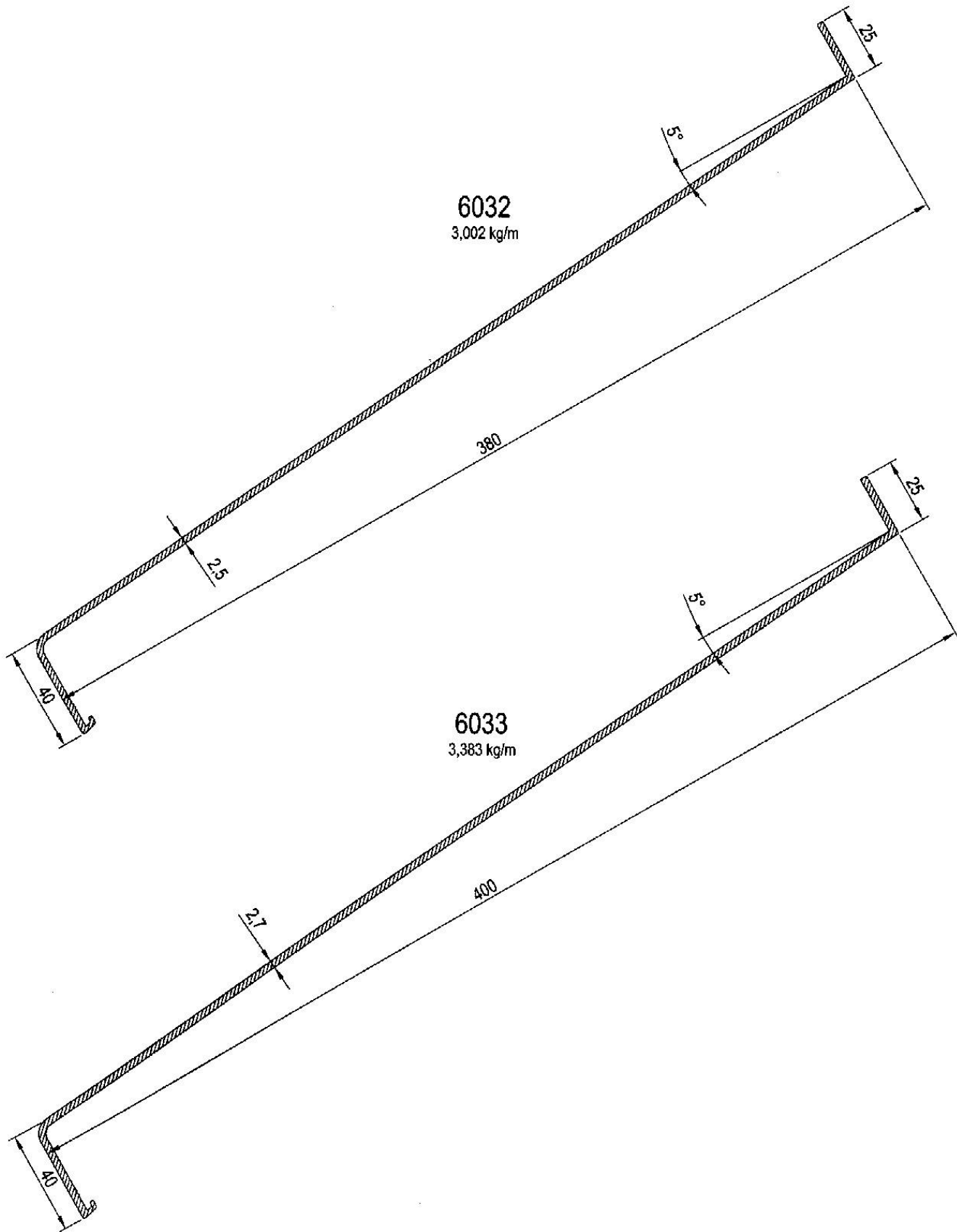

4457
0,665 kg/m

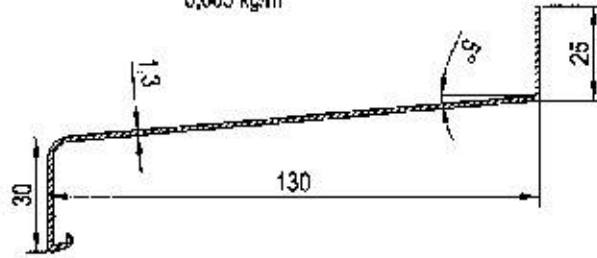

4456
0,737 kg/m

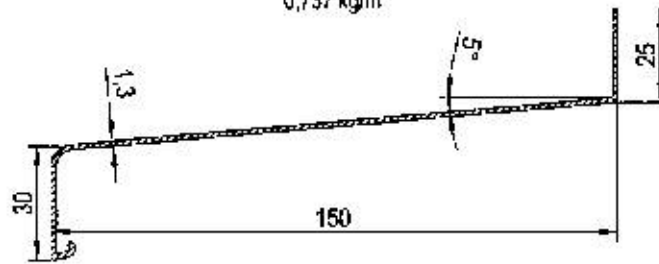

4455
0,807 kg/m

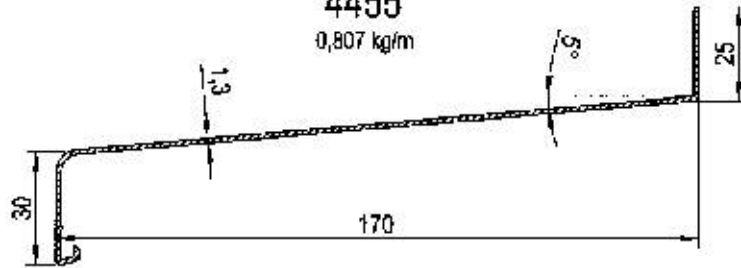

4454
0,879 kg/m

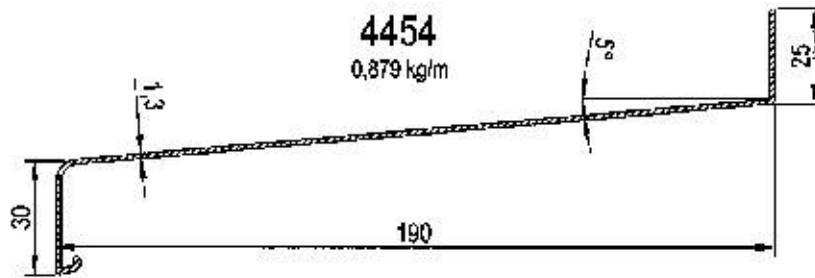

4453
1,020 kg/m

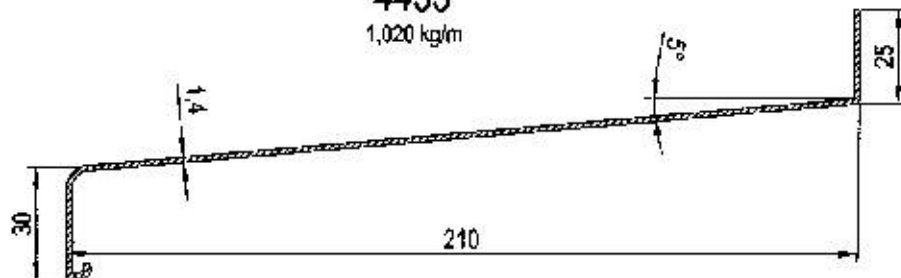

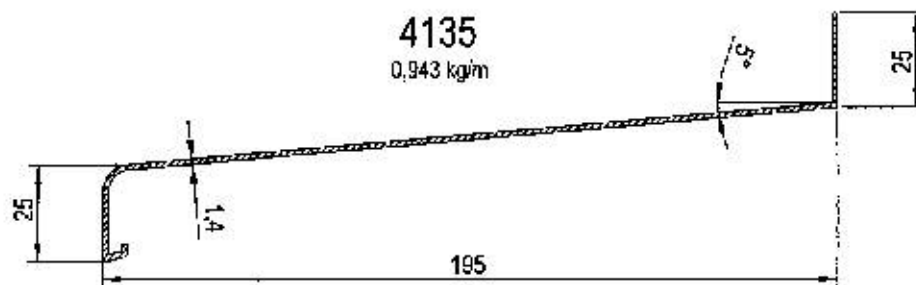
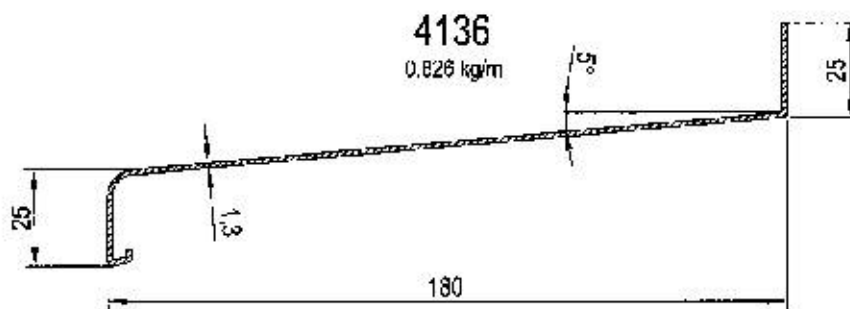
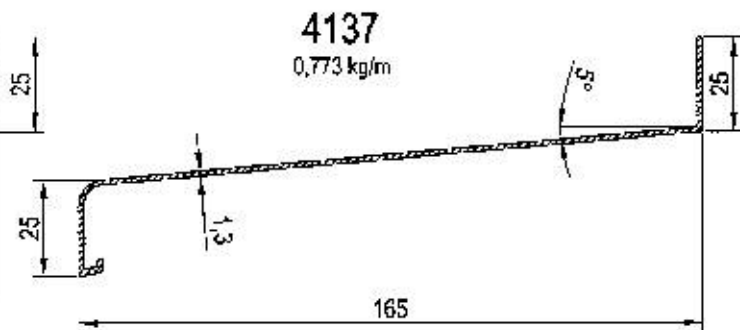
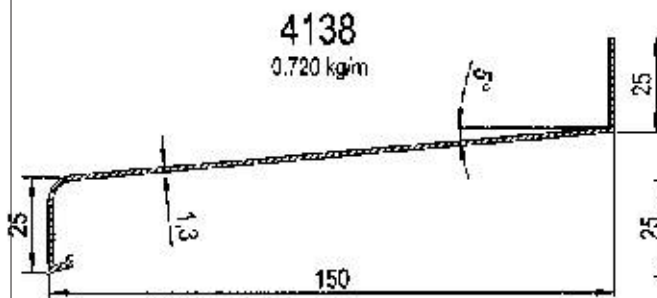
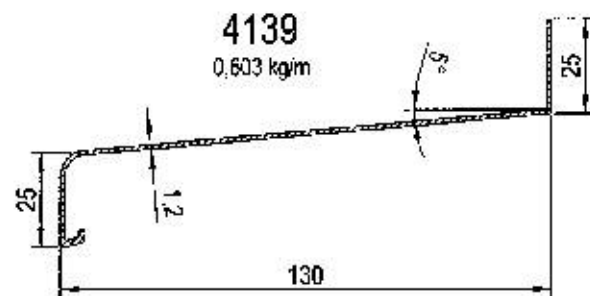
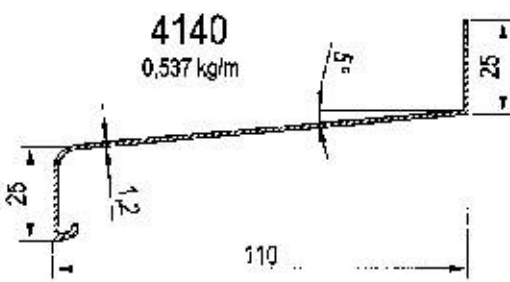
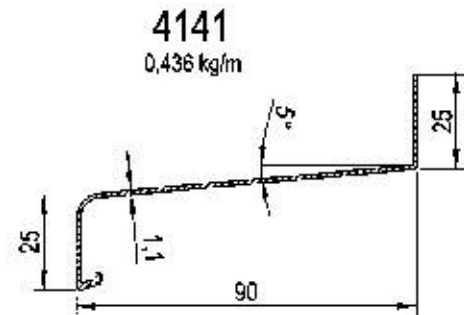
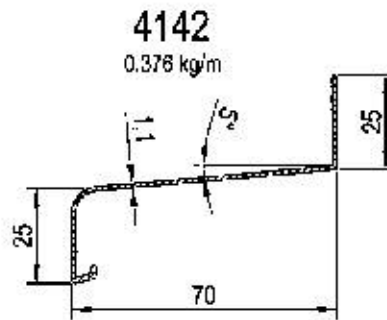
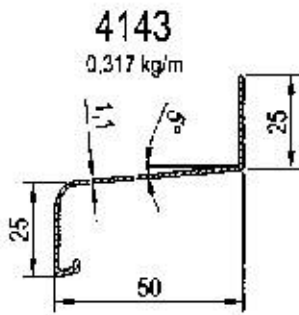

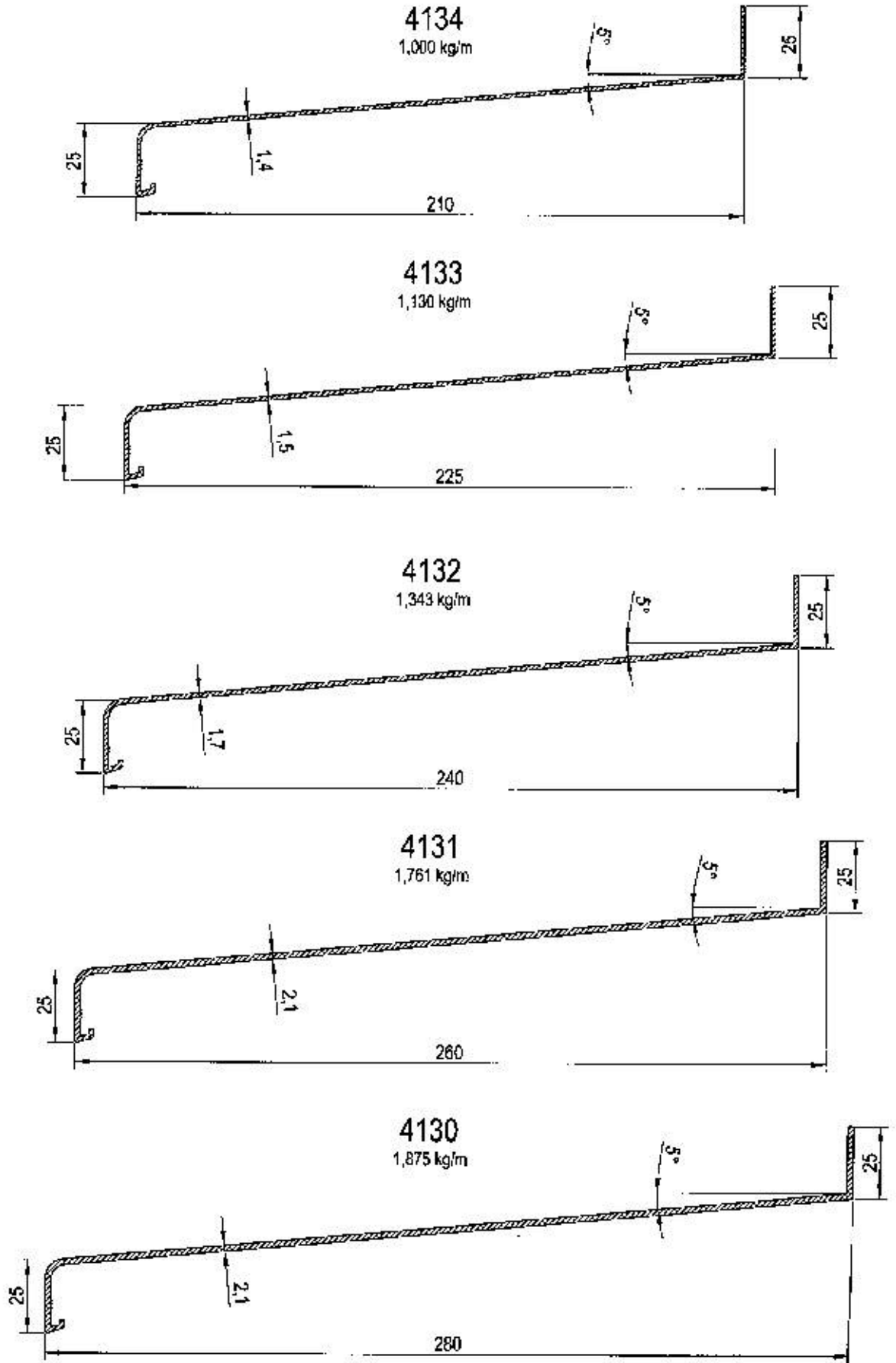

4213
2,081 kg/m

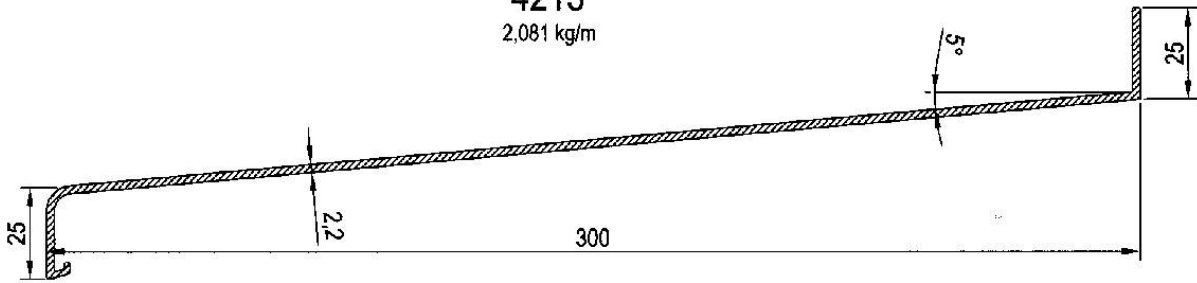

3261
2,108 kg/m

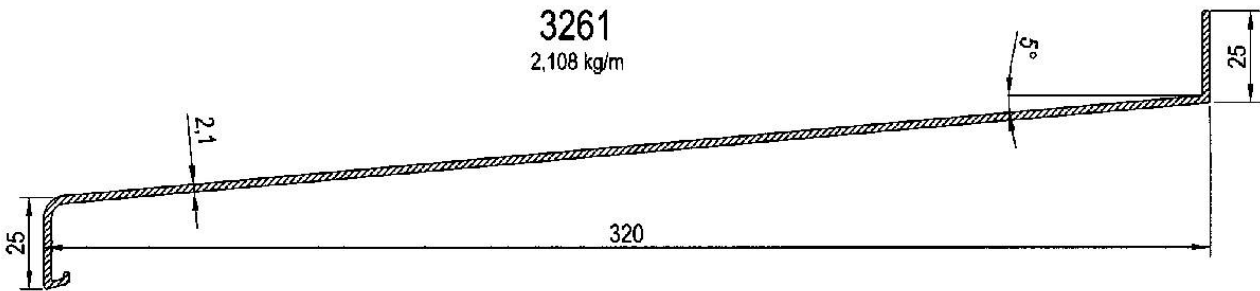

4212
2,321 kg/m

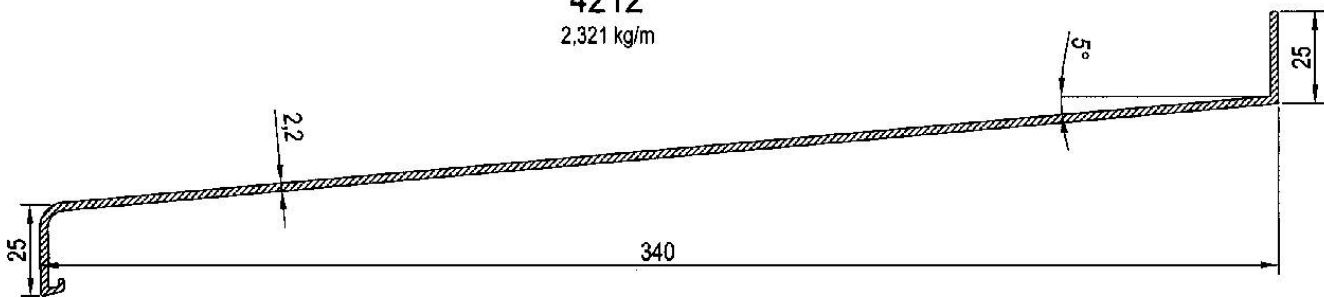

6085
2,548 kg/m

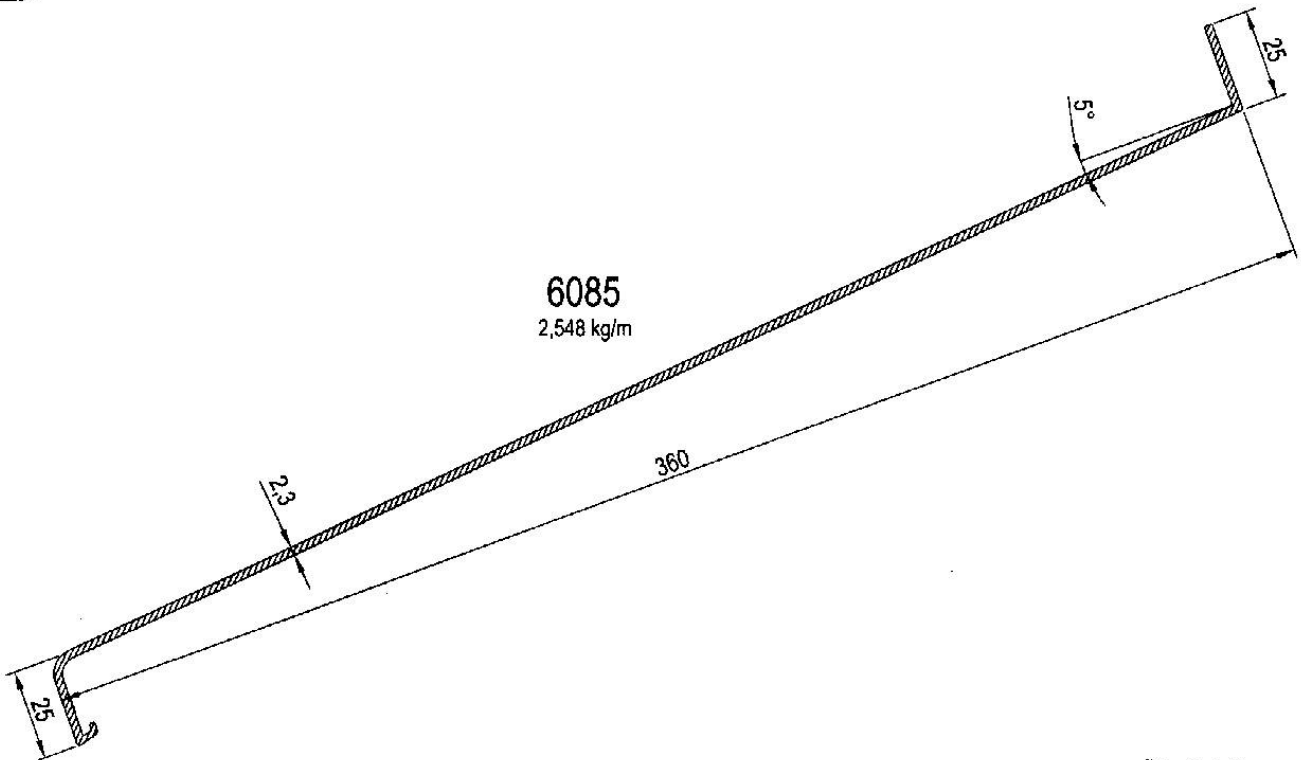

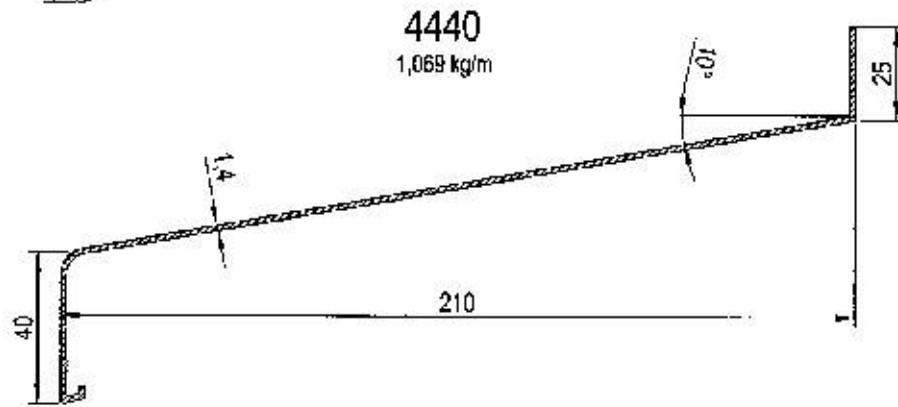
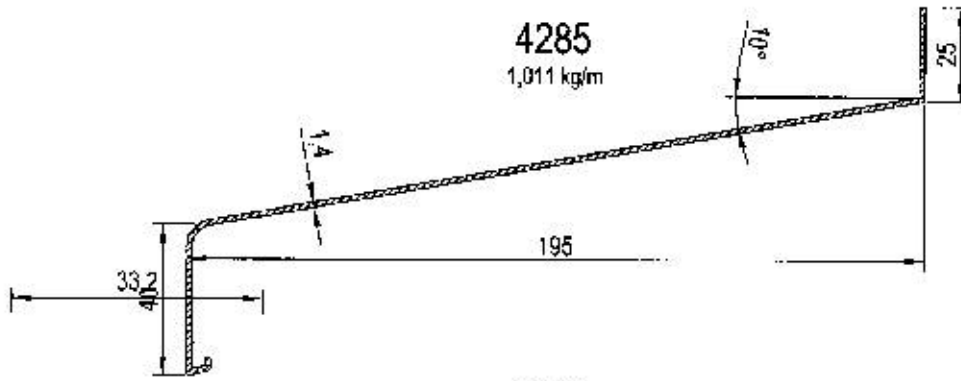
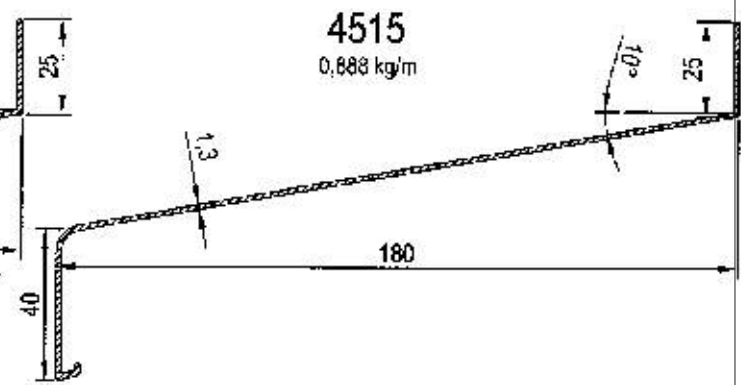
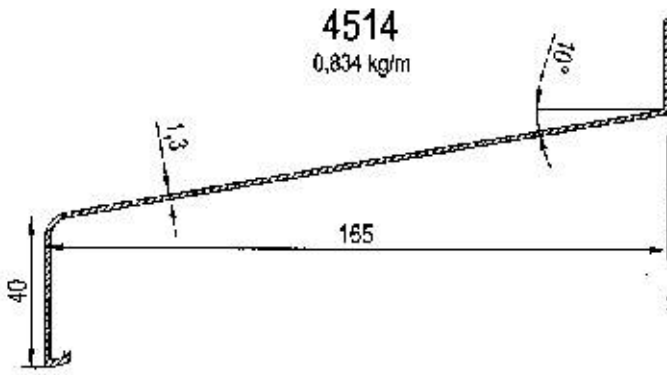
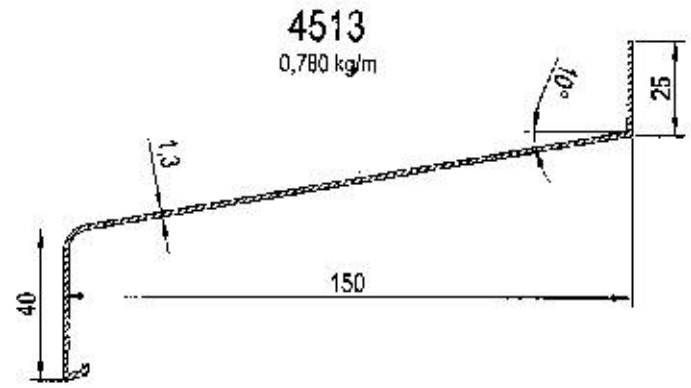
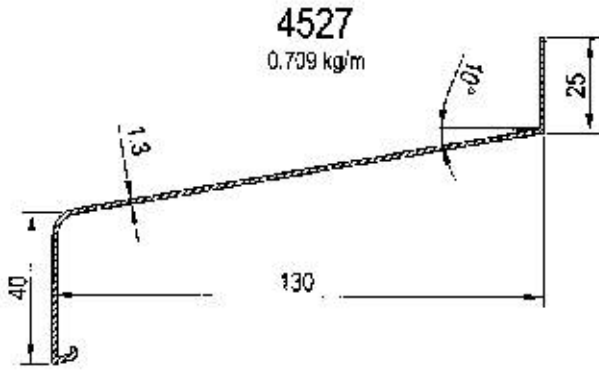

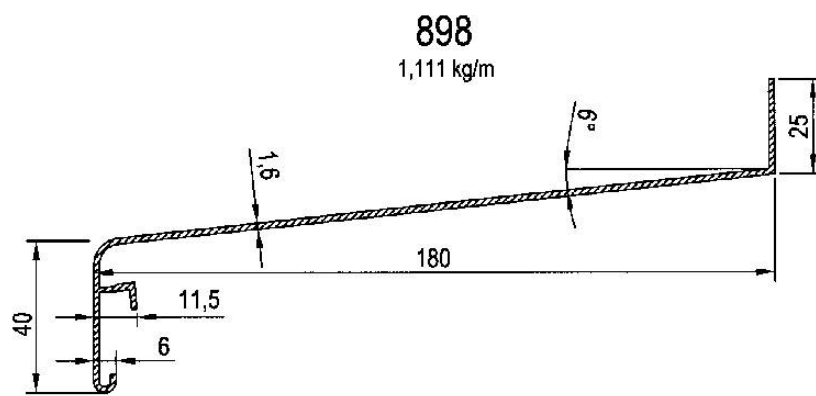
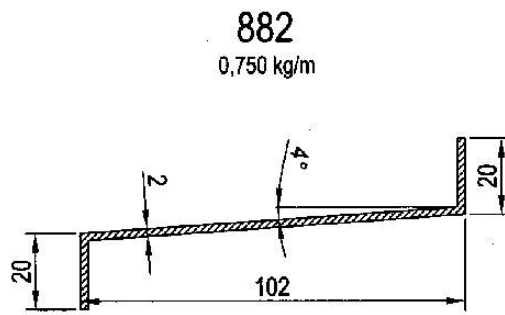
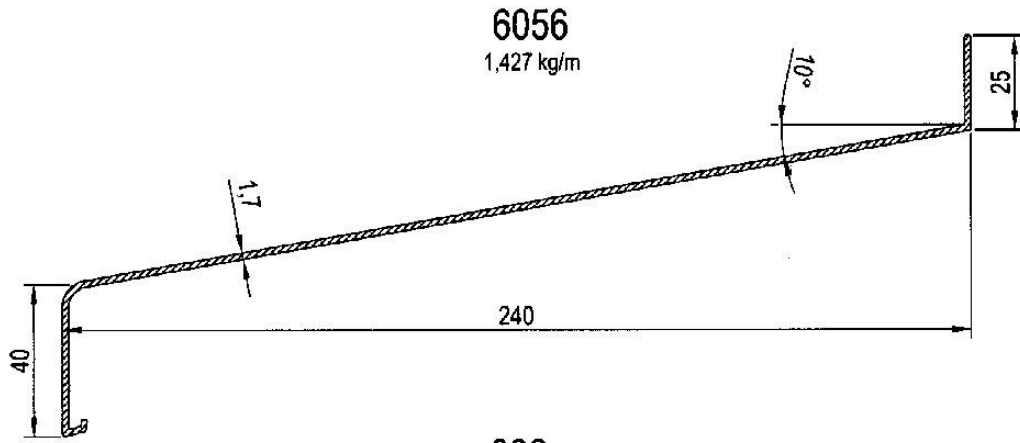





Alucomplast

Paneling Profiles
Hliníkové Výplně

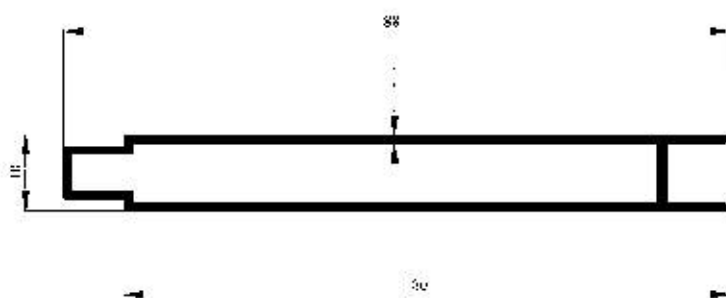

Profil No : 2000
Gramaj : 0.570 kg/m
Çevre : 212 mm

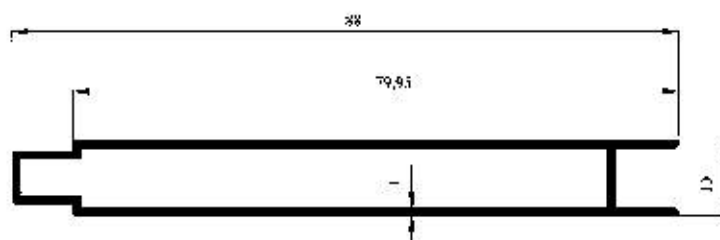

Profil No : 2077
Gramaj : 0.524 kg/m
Çevre : 212 mm

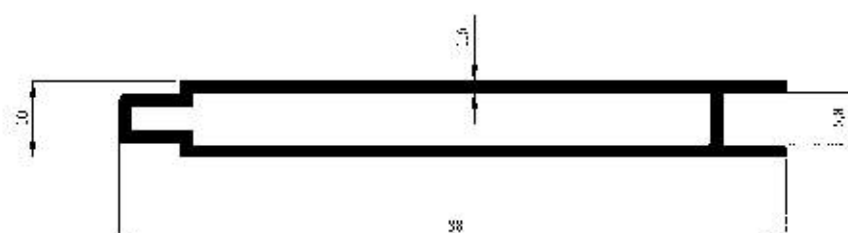

Profil No : 2087
Gramaj : 0.821 kg/m
Çevre : 212 mm



Profil No : 2088
Gramaj : 0.969 kg/m
Çevre : 212 mm

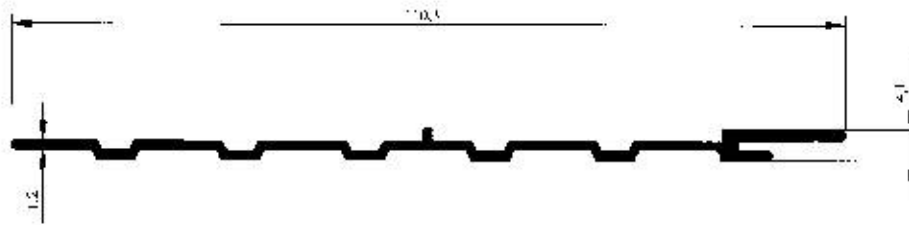

Profil No : 2664
 Gramaj : 0.425 kg/m
 Çevre : 252 mm

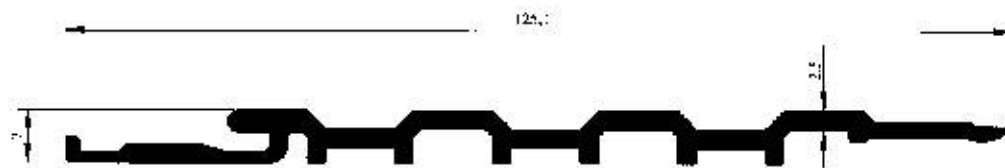

Profil No : 2735
 Gramaj : 1.010 kg/m
 Çevre : 315 mm

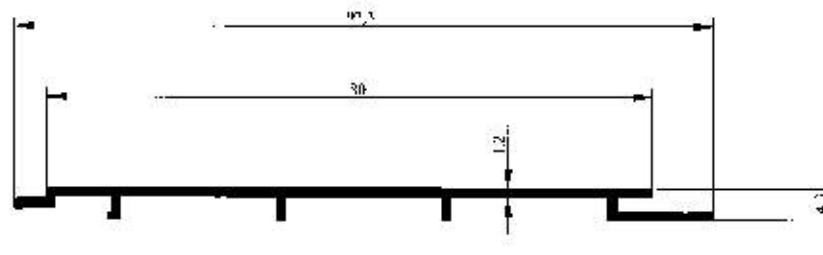

Profil No : 3000
 Gramaj : 0.363 kg/m
 Çevre : 224 mm

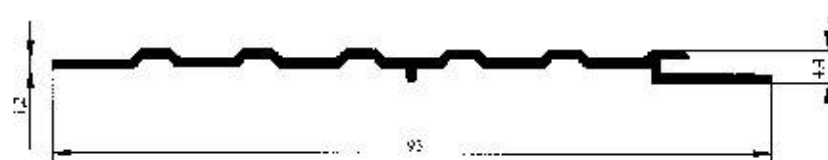

Profil No : 3001
 Gramaj : 0.354 kg/m
 Çevre : 219 mm

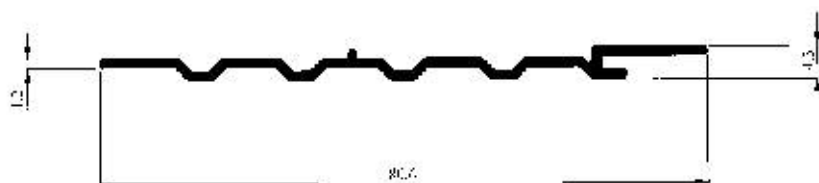

Profil No : 3238
Gramaj : 0.309 kg/m
Çevre : 187 mm

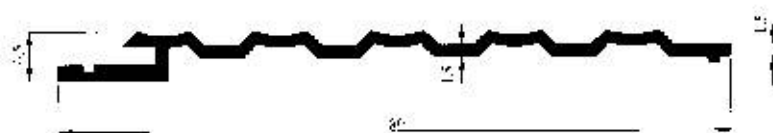

Profil No : 3281
Gramaj : 0.445 kg/m
Çevre : 217 mm

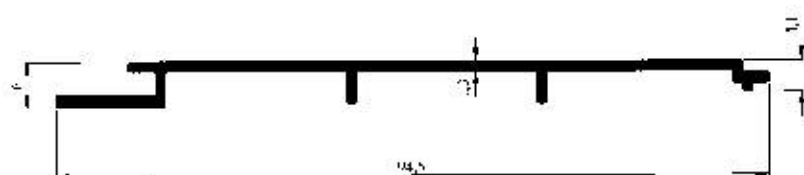

Profil No : 3320
Gramaj : 0.420 kg/m
Çevre : 229 mm



Profil No : 3228
Gramaj : 0.282 kg/m
Çevre : 207 mm

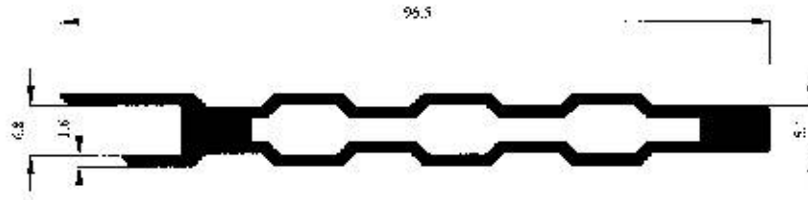

Profil No : 3487
 Gramaj : 1.024 kg/m
 Çevre : 234 mm

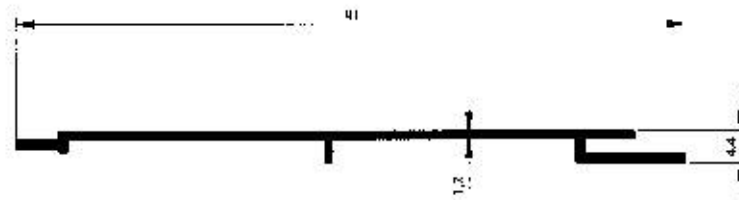

Profil No : 3635
 Gramaj : 0.343 kg/m
 Çevre : 214 mm

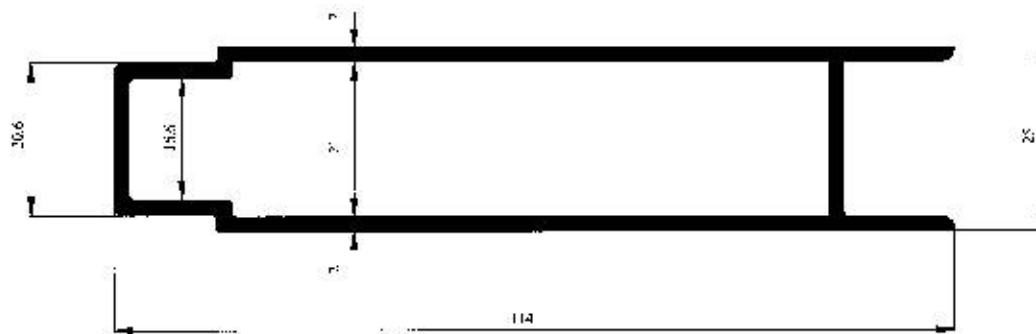

Profil No : 3502
 Gramaj : 1.460 kg/m
 Çevre : 305 mm

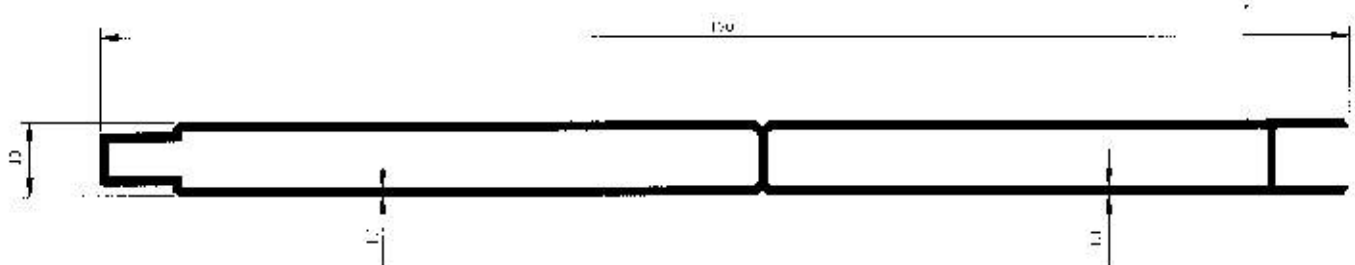

Profil No : 4197
 Gramaj : 1.079 kg/m
 Çevre : 379 mm





Alucomplast

Reklamní stojany, rámy, Klaprámy
Picture Frame Profiles

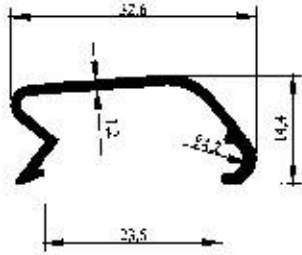

Profil No : 2733
Gramaj : 0.195 kg/m
Çevre : 119 mm

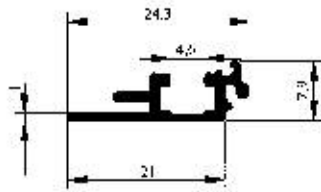

Profil No : 2742
Gramaj : 0.141 kg/m
Çevre : 93 mm

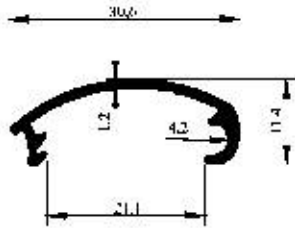

Profil No : 2766
Gramaj : 0.170 kg/m
Çevre : 100 mm

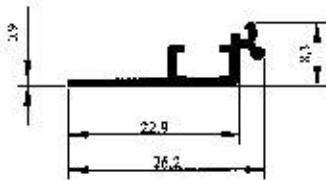

Profil No : 2798
Gramaj : 0.115 kg/m
Çevre : 84 mm

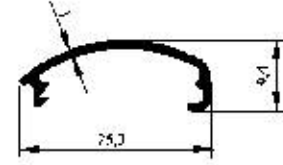

Profil No : 2741
Gramaj : 0.106 kg/m
Çevre : 78 mm

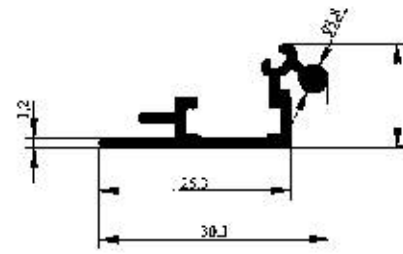

Profil No : 2757
Gramaj : 0.227 kg/m
Çevre : 126 mm

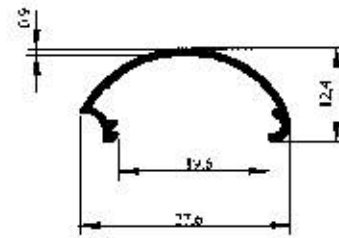

Profil No : 2797
Gramaj : 0.116 kg/m
Çevre : 92 mm

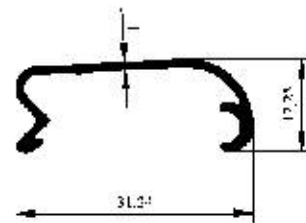

Profil No : 2799
Gramaj : 0.166 kg/m
Çevre : 114 mm

Reklamní stojany, rámy, Klaprámy
Picture Frame Profiles

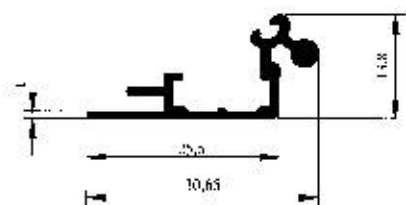

Profil No : 2800
Gramaj : 0.202 kg/m
Çevre : 121 mm

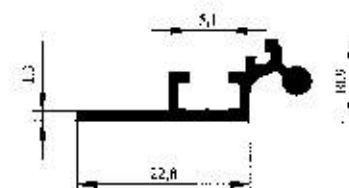

Profil No : 2832
Gramaj : 0.202 kg/m
Çevre : 105 mm

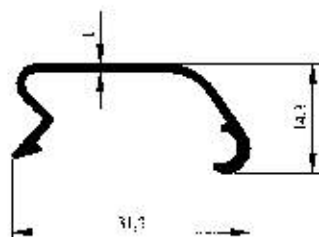

Profil No : 2864
Gramaj : 0.164 kg/m
Çevre : 114 mm

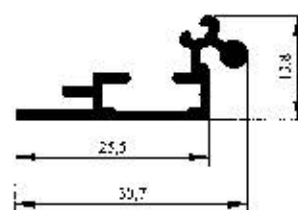

Profil No : 2886
Gramaj : 0.225 kg/m
Çevre : 129 mm

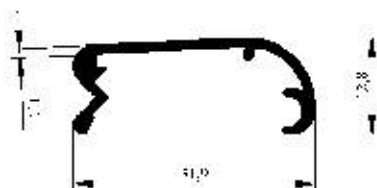

Profil No : 2887
Gramaj : 0.208 kg/m
Çevre : 118 mm

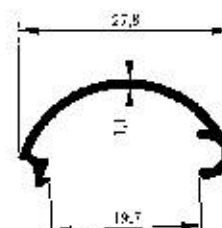

Profil No : 2888
Gramaj : 0.145 kg/m
Çevre : 97 mm

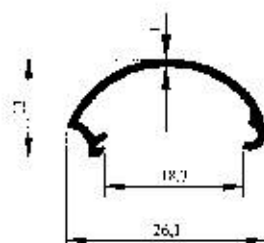

Profil No : 2893
Gramaj : 0.123 kg/m
Çevre : 83 mm

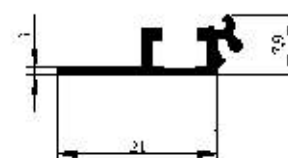

Profil No : 2894
Gramaj : 0.126 kg/m
Çevre : 83 mm

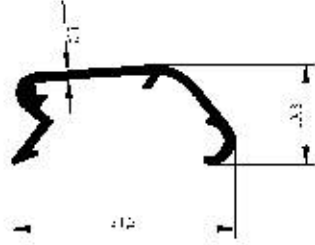

Profil No : 2895
Gramaj : 0.205 kg/m
Çevre : 118 mm

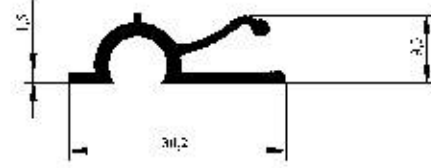

Profil No : 2897
Gramaj : 0.245 kg/m
Çevre : 115 mm

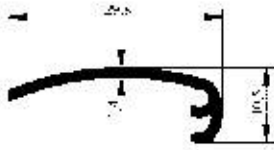

Profil No : 2898
Gramaj : 0.158 kg/m
Çevre : 84 mm

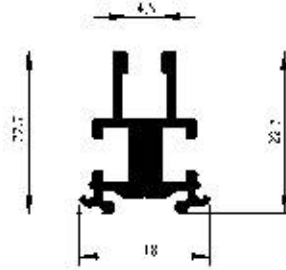

Profil No : 2933
Gramaj : 0.340 kg/m
Çevre : 147 mm

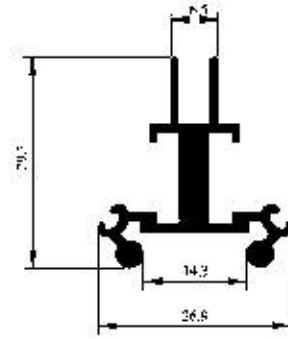

Profil No : 2934
Gramaj : 0.429 kg/m
Çevre : 189 mm

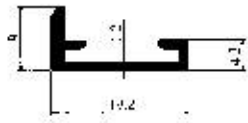

Profil No : 3092
Gramaj : 0.128 kg/m
Çevre : 67 mm

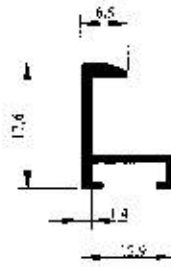

Profil No : 3110
Gramaj : 0.138 kg/m
Çevre : 82 mm

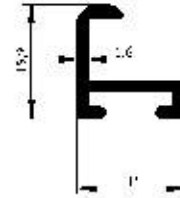

Profil No : 3162
Gramaj : 0.179 kg/m
Çevre : 84 mm

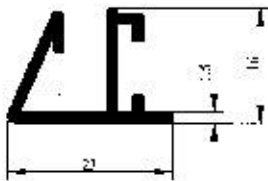

Profil No : 3163
Gramaj : 0.263 kg/m
Çevre : 129 mm

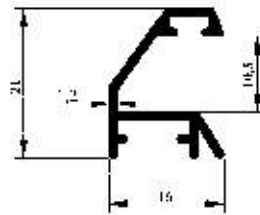

Profil No : 3164
Gramaj : 0.201 kg/m
Çevre : 120 mm

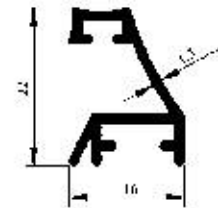

Profil No : 3165
Gramaj : 0.236 kg/m
Çevre : 127 mm

Reklamní stojany, rámy, Klaprámy
Picture Frame Profiles

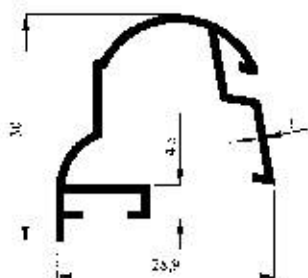

Profil No : 3217
Gramaj : 0.268 kg/m
Çevre : 198 mm

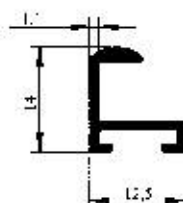

Profil No : 3245
Gramaj : 0.118 kg/m
Çevre : 75 mm

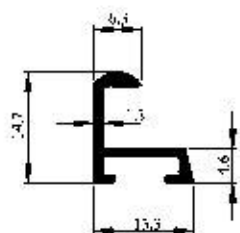

Profil No : 3406
Gramaj : 0.127 kg/m
Çevre : 76 mm

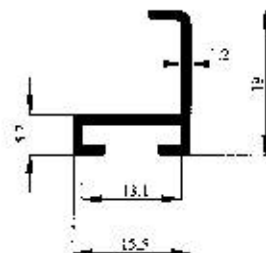

Profil No : 3441
Gramaj : 0.153 kg/m
Çevre : 94 mm

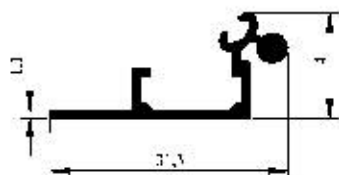

Profil No : 3570
Gramaj : 0.190 kg/m
Çevre : 116 mm



Profil No : 3571
Gramaj : 0.162 kg/m
Çevre : 116 mm

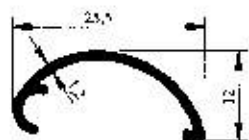

Profil No : 3596
Gramaj : 0.134 kg/m
Çevre : 81 mm

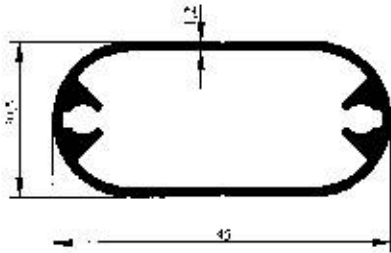

Profil No : 1927
Gramaj : 0.483 kg/m
Çevre : 114 mm

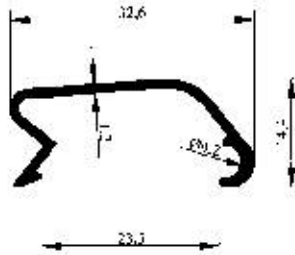

Profil No : 2733
Gramaj : 0.195 kg/m
Çevre : 119 mm

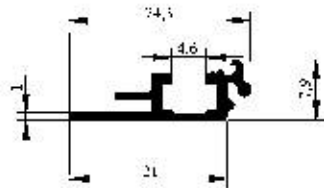

Profil No : 2742
Gramaj : 0.141 kg/m
Çevre : 93 mm

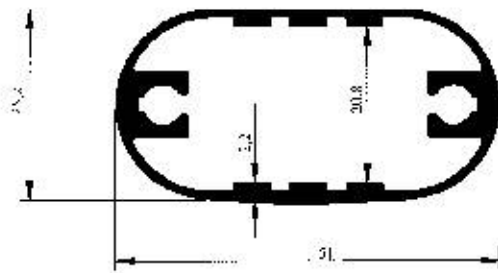

Profil No : 2753
Gramaj : 0.751 kg/m
Çevre : 322 mm

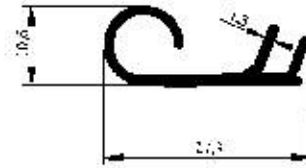

Profil No : 2653
Gramaj : 0.203 kg/m
Çevre : 111 mm

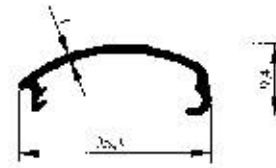

Profil No : 2741
Gramaj : 0.106 kg/m
Çevre : 78 mm

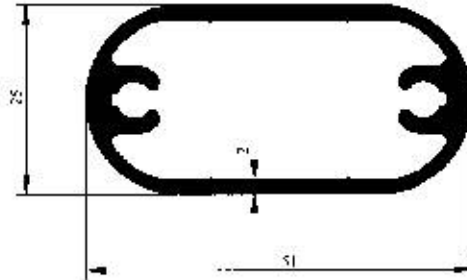

Profil No : 2746
Gramaj : 0.908 kg/m
Çevre : 131 mm

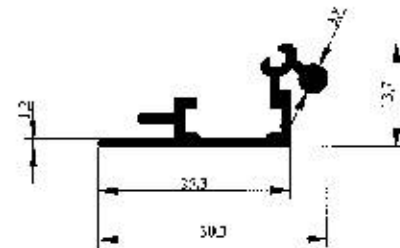

Profil No : 2757
Gramaj : 0.227 kg/m
Çevre : 126 mm

Reklamní stojany, rámy, Klaprámy
Picture Frame Profiles

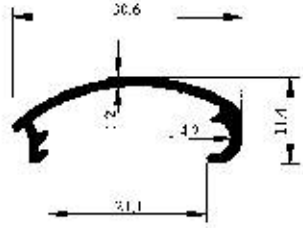

Profil No : 2766
Gramaj : 0.170 kg/m
Çevre : 100 mm

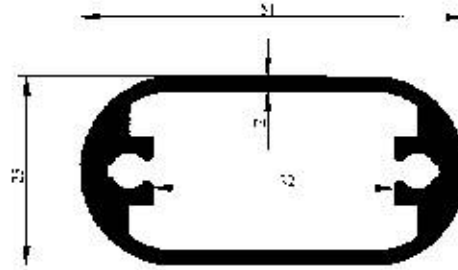

Profil No : 2728
Gramaj : 0.986 kg/m
Çevre : 131 mm

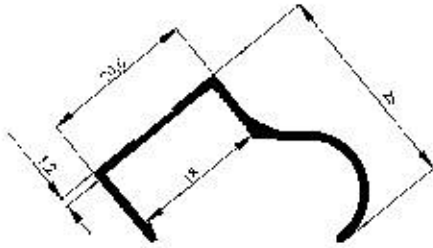

Profil No : 2678
Gramaj : 0.214 kg/m
Çevre : 140 mm

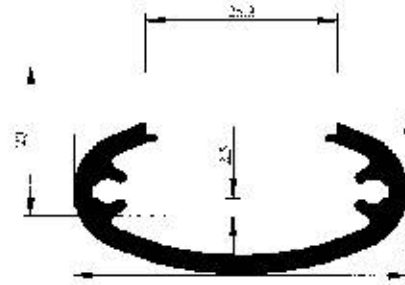

Profil No : 2899
Gramaj : 0.589 kg/m
Çevre : 176 mm

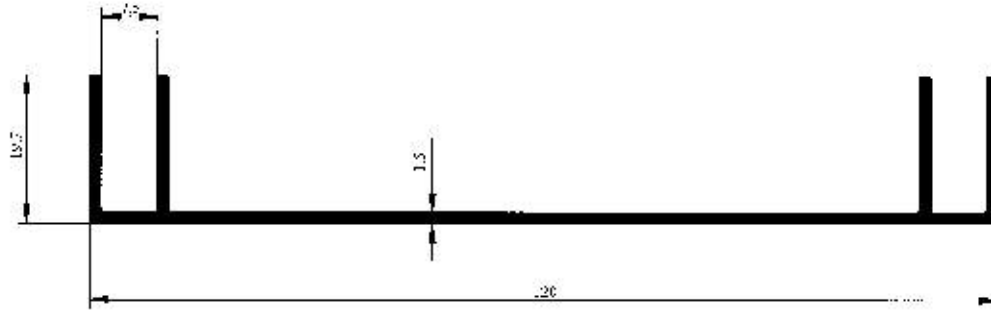

Profil No : 2862
Gramaj : 0.783 kg/m
Çevre : 385 mm

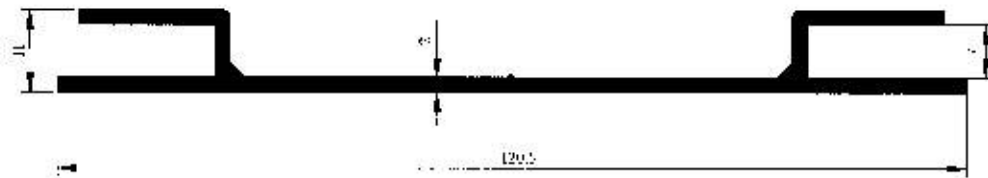

Profil No : 2863
Gramaj : 0.957 kg/m
Çevre : 351 mm



Reklamní stojany, rámy, Klaprámy
Picture Frame Profiles

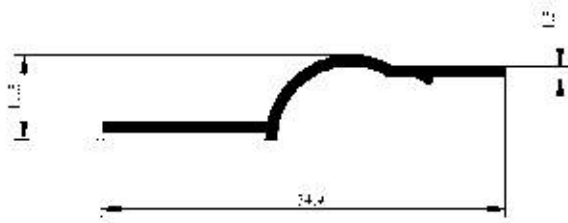

Profil No : 2923
 Gramaj : 0.250 kg/m
 Çevre : 125 mm

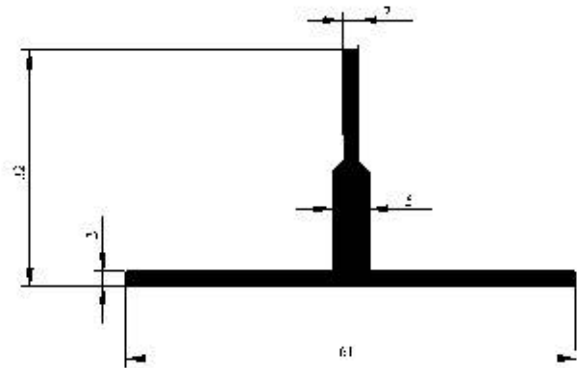

Profil No : 2924
 Gramaj : 0.609 kg/m
 Çevre : 183 mm

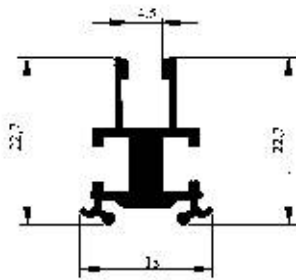

Profil No : 2933
 Gramaj : 0.340 kg/m
 Çevre : 147 mm

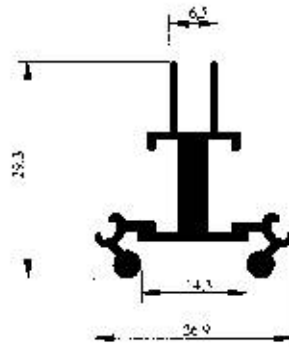

Profil No : 2934
 Gramaj : 0.429 kg/m
 Çevre : 189 mm

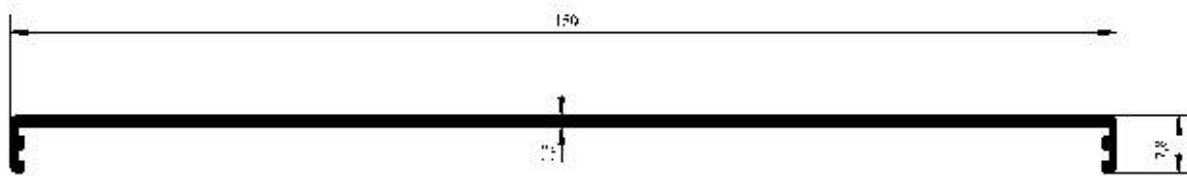

Profil No : 2937
 Gramaj : 0.658 kg/m
 Çevre : 336 mm

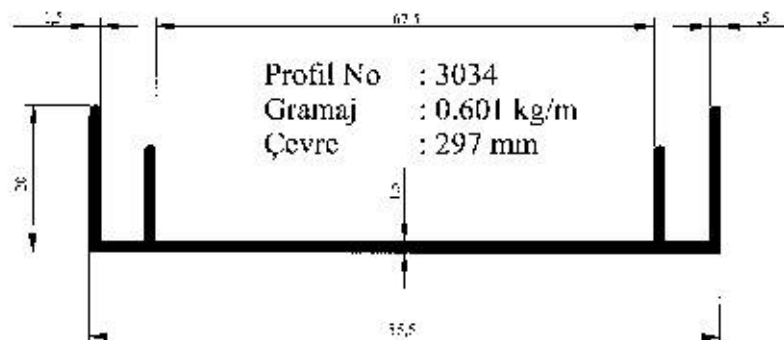

Profil No : 3034
 Gramaj : 0.601 kg/m
 Çevre : 297 mm

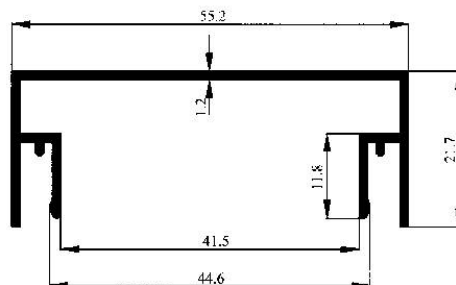

Profil No : 3080
Gramaj : 0.431 kg/m
Çevre : 266 mm

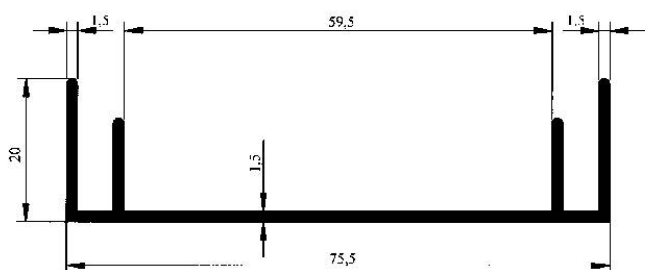

Profil No : 3035
Gramaj : 0.560 kg/m
Çevre : 277 mm

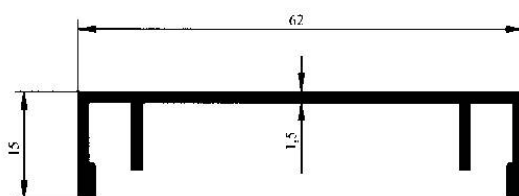

Profil No : 3036
Gramaj : 0.463 kg/m
Çevre : 222 mm

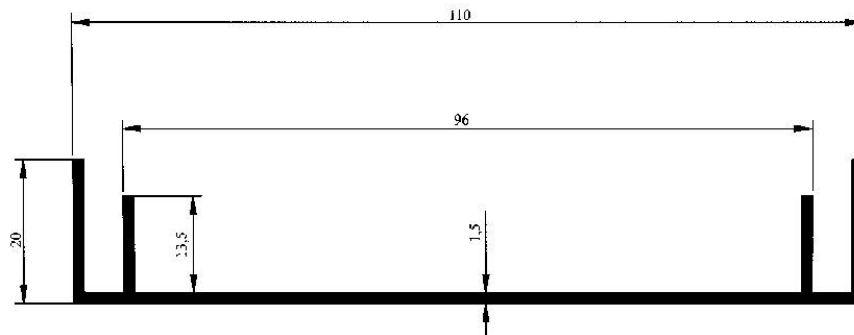

Profil No : 3630
Gramaj : 0.707 kg/m
Çevre : 350 mm

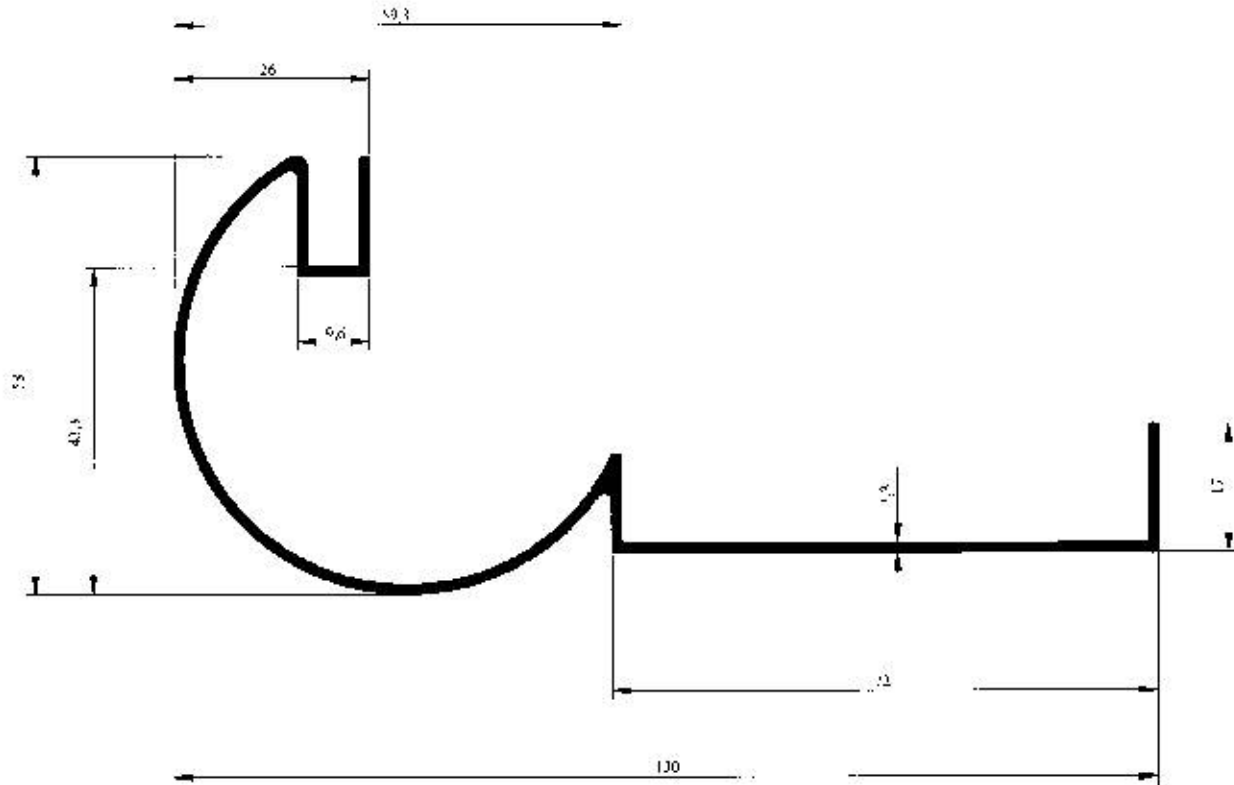

Profil No : 3654
Gramaj : 0.707 kg/m
Çevre : 495 mm

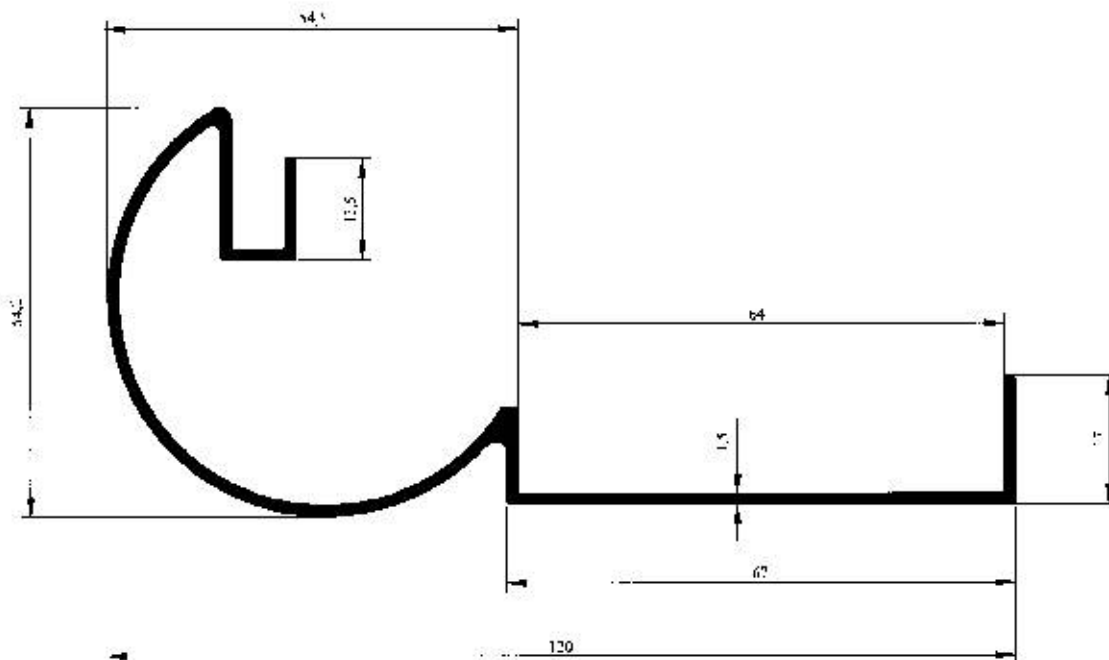

Profil No : 3687
Gramaj : 0.889 kg/m
Çevre : 468 mm



Alucomplast

Stair Noising Profiles
Řechodové lišty - Obkladové lišty

Stair Noising Profiles
Přechodové lišty - Obkladové lišty

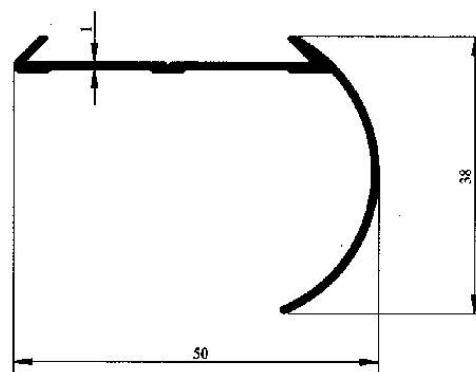
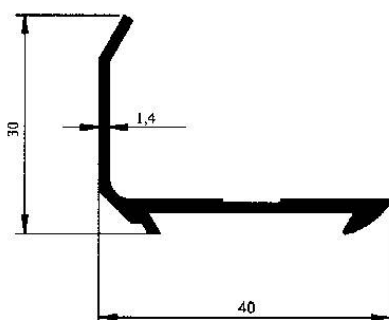
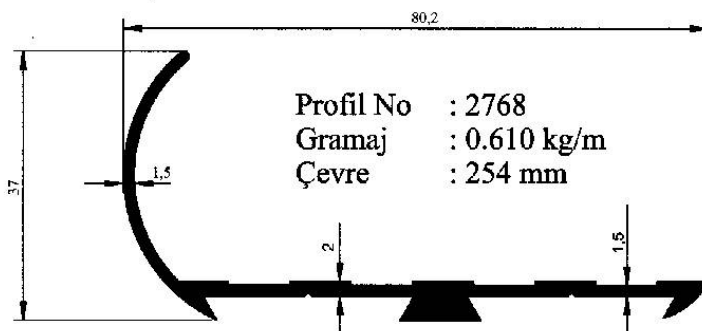
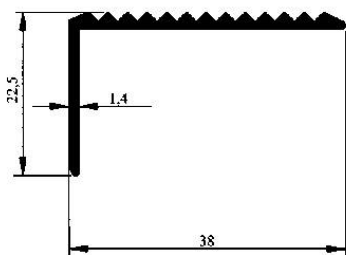
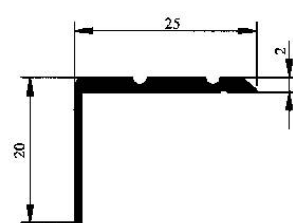
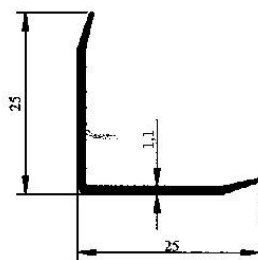
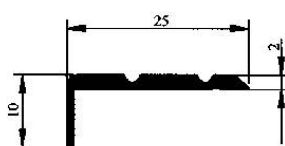
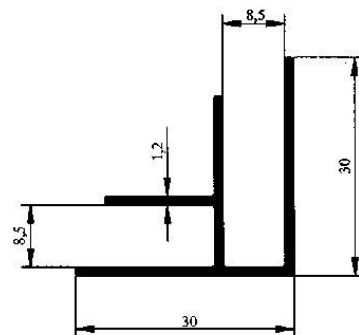
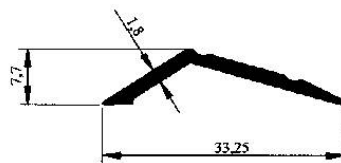
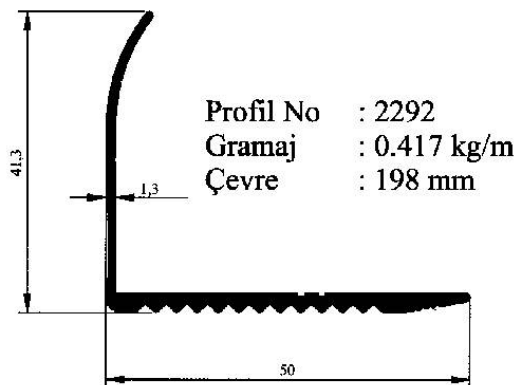

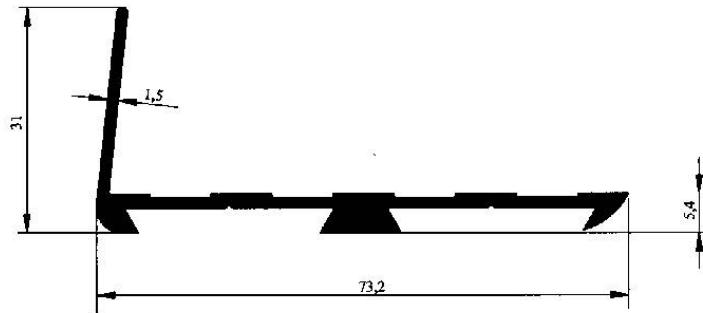

Profil No : 2870
 Gramaj : 0.587 kg/m
 Çevre : 230 mm

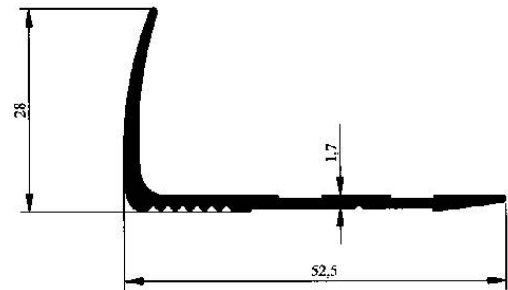

Profil No : 2878
 Gramaj : 0.347 kg/m
 Çevre : 164 mm

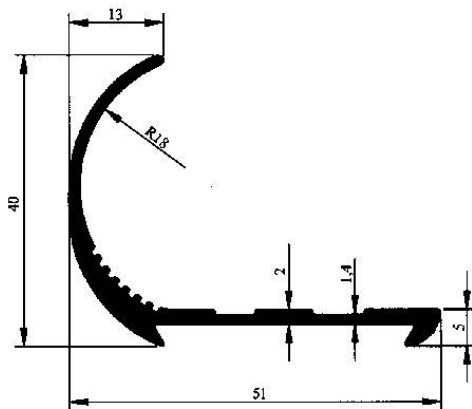

Profil No : 3037
 Gramaj : 0.496 kg/m
 Çevre : 196 mm

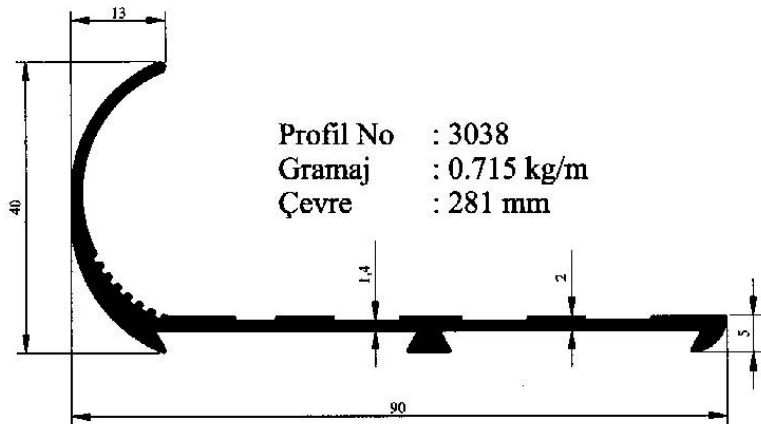

Profil No : 3038
 Gramaj : 0.715 kg/m
 Çevre : 281 mm

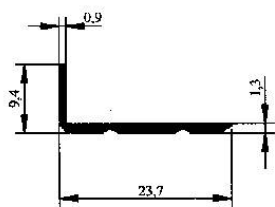

Profil No : 3779
 Gramaj : 0.095 kg/m
 Çevre : 65 mm

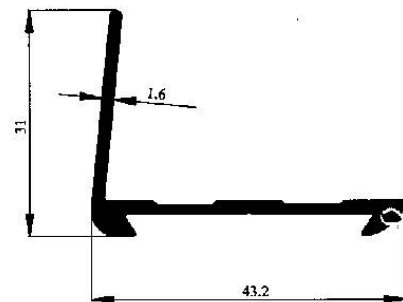

Profil No : 3098
 Gramaj : 0.360 kg/m
 Çevre : 154 mm

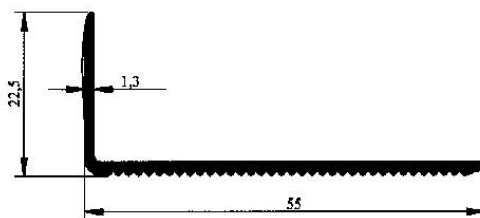

Profil No : 3964
 Gramaj : 0.298 kg/m
 Çevre : 172 mm

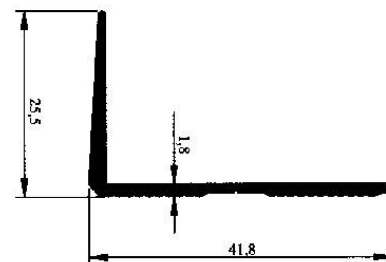

Profil No : 8018
 Gramaj : 0.275 kg/m
 Çevre : 134 mm

Stair Noising Profiles
Přechodové lišty - Obkladové lišty

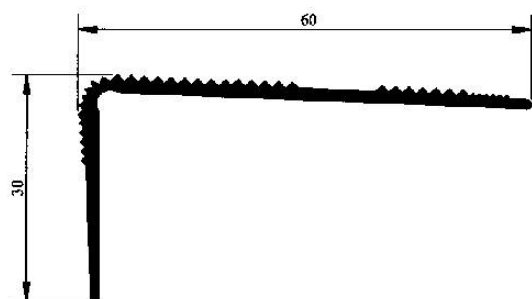

Profil No : 4717
Gramaj : 0.379 kg/m
Çevre : 197 mm

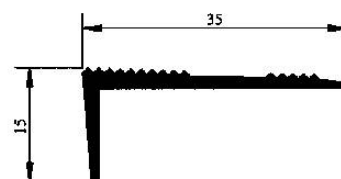

Profil No : 4718
Gramaj : 0.215 kg/m
Çevre : 104 mm

Stair Noising Profiles
Přechodové lišty - Obkladové lišty

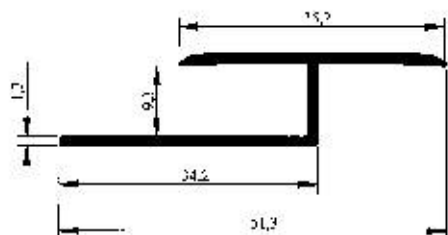

Profil No : 2696
 Gramaj : 0.293 kg/m
 Çevre : 159 mm

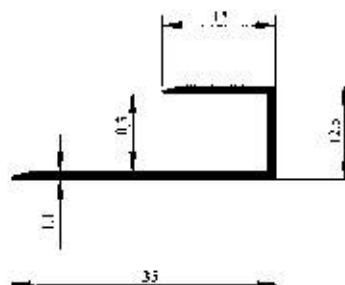

Profil No : 2721
 Gramaj : 0.174 kg/m
 Çevre : 121 mm

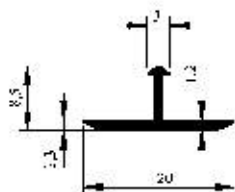

Profil No : 2726
 Gramaj : 0.084 kg/m
 Çevre : 57 mm

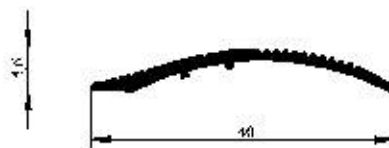

Profil No : 2737
 Gramaj : 0.168 kg/m
 Çevre : 94 mm

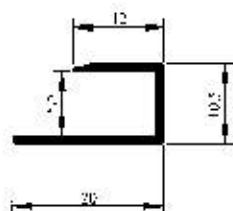

Profil No : 2754
 Gramaj : 0.107 kg/m
 Çevre : 81 mm

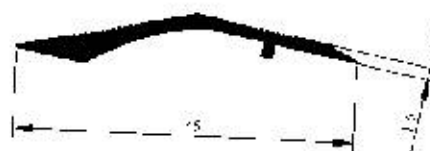

Profil No : 2755
 Gramaj : 0.234 kg/m
 Çevre : 102 mm

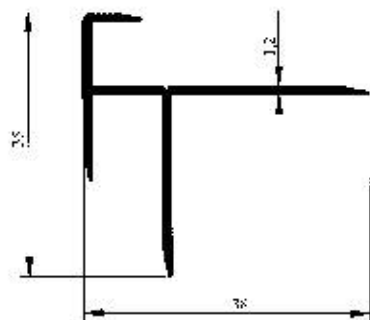

Profil No : 2876
 Gramaj : 0.274 kg/m
 Çevre : 180 mm



Profil No : 2885
 Gramaj : 0.156 kg/m
 Çevre : 133 mm

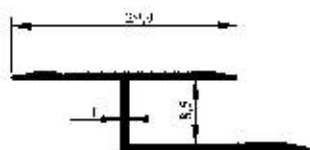

Profil No : 2994
 Gramaj : 0.157 kg/m
 Çevre : 134 mm

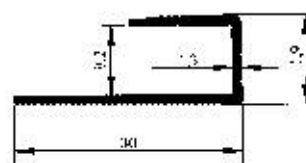

Profil No : 2996
 Gramaj : 0.168 kg/m
 Çevre : 116 mm

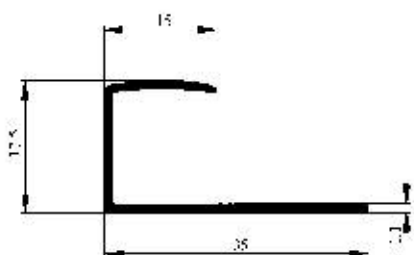

Profil No : 3069
 Gramaj : 0.190 kg/m
 Çevre : 129 mm

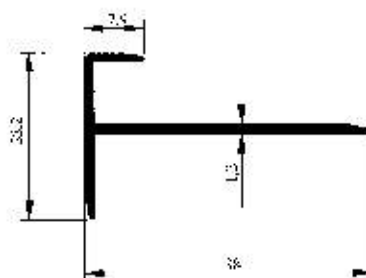

Profil No : 3176
 Gramaj : 0.199 kg/m
 Çevre : 132 mm

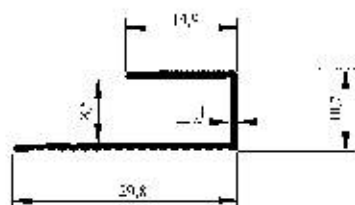

Profil No : 8005
 Gramaj : 0.138 kg/m
 Çevre : 133 mm

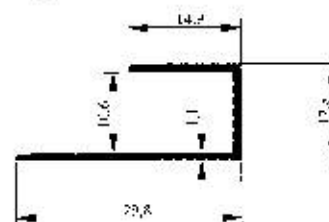

Profil No : 8015
 Gramaj : 0.144 kg/m
 Çevre : 118 mm

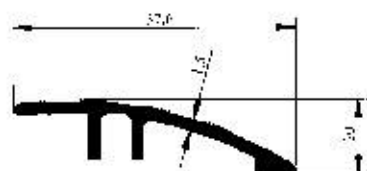

Profil No : 8030
 Gramaj : 0.219 kg/m
 Çevre : 216 mm

Stair Noising Profiles
Přechodové lišty - Obkladové lišty

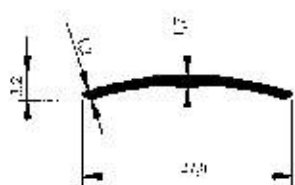

Profil No : 2255
 Gramaj : 0.093 kg/m
 Çevre : 59 mm



Profil No : 2290
 Gramaj : 0.133 kg/m
 Çevre : 73 mm

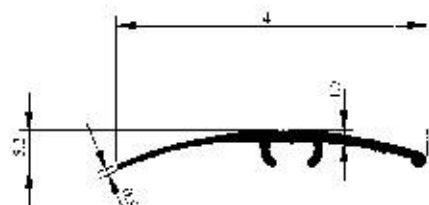

Profil No : 2722
 Gramaj : 0.160 kg/m
 Çevre : 100 mm

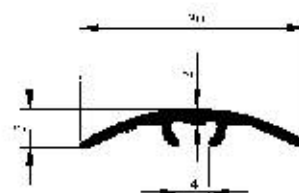

Profil No : 2723
 Gramaj : 0.140 kg/m
 Çevre : 77 mm

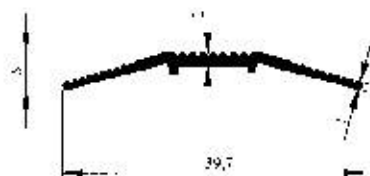

Profil No : 2738
 Gramaj : 0.146 kg/m
 Çevre : 97 mm

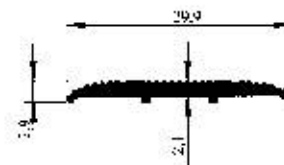

Profil No : 2739
 Gramaj : 0.144 kg/m
 Çevre : 72 mm

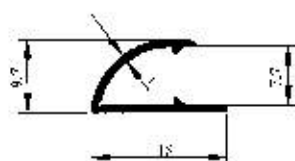

Profil No : 2763
 Gramaj : 0.099 kg/m
 Çevre : 75 mm

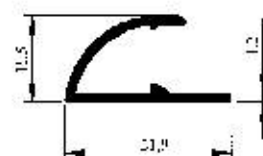

Profil No : 2769
 Gramaj : 0.141 kg/m
 Çevre : 88 mm

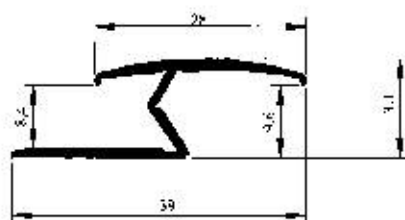

Profil No : 2770
 Gramaj : 0.205 kg/m
 Çevre : 134 mm

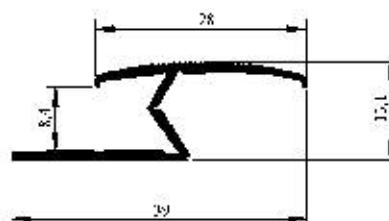

Profil No : 2771
 Gramaj : 0.199 kg/m
 Çevre : 139 mm

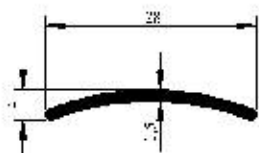

Profil No : 2772
 Gramaj : 0.115 kg/m
 Çevre : 59 mm

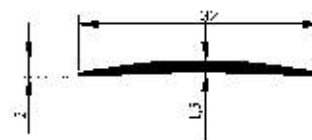

Profil No : 2773
 Gramaj : 0.103 kg/m
 Çevre : 65 mm

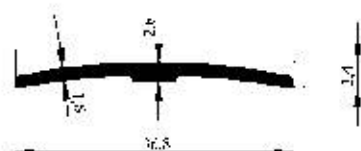

Profil No : 2780
 Gramaj : 0.175 kg/m
 Çevre : 77 mm

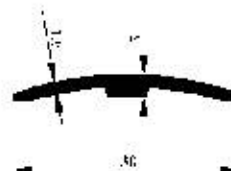

Profil No : 2781
 Gramaj : 0.147 kg/m
 Çevre : 64 mm

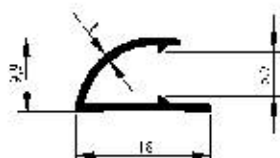

Profil No : 2861
 Gramaj : 0.103 kg/m
 Çevre : 75 mm

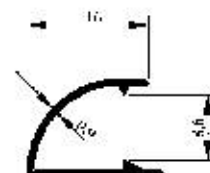

Profil No : 2877
 Gramaj : 0.103 kg/m
 Çevre : 85 mm

Stair Noising Profiles
Přechodové lišty - Obkladové lišty

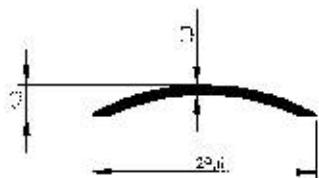

Profil No : 2879
 Gramaj : 0.103 kg/m
 Çevre : 62 mm

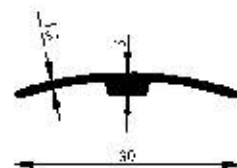

Profil No : 2883
 Gramaj : 0.125 kg/m
 Çevre : 65 mm

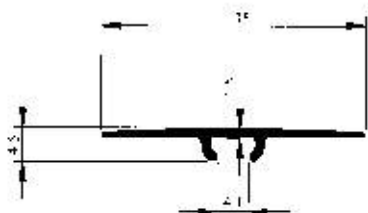

Profil No : 2908
 Gramaj : 0.126 kg/m
 Çevre : 83 mm

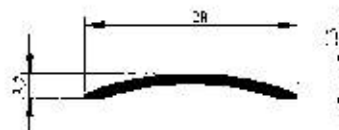

Profil No : 2940
 Gramaj : 0.099 kg/m
 Çevre : 58 mm

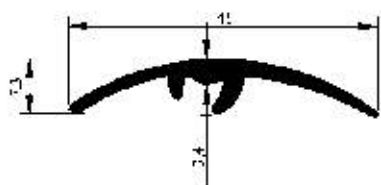

Profil No : 2997
 Gramaj : 0.256 kg/m
 Çevre : 103 mm

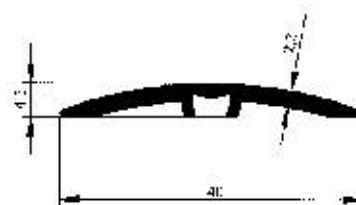

Profil No : 2998
 Gramaj : 0.237 kg/m
 Çevre : 92 mm

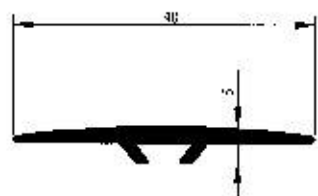

Profil No : 2999
 Gramaj : 0.221 kg/m
 Çevre : 93 mm

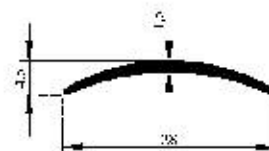

Profil No : 3102
 Gramaj : 0.098 kg/m
 Çevre : 59 mm

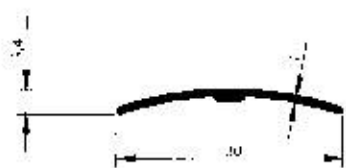

Profil No : 3995
 Gramaj : 0.090 kg/m
 Çevre : 63 mm

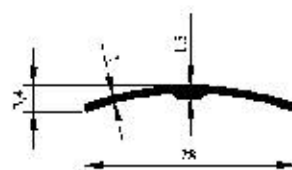

Profil No : 3996
 Gramaj : 0.085 kg/m
 Çevre : 59 mm

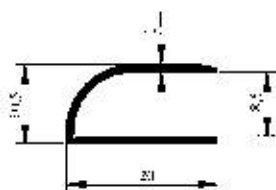

Profil No : 3997
 Gramaj : 0.119 kg/m
 Çevre : 91 mm

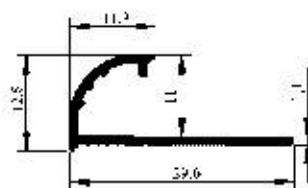

Profil No : 8008
 Gramaj : 0.150 kg/m
 Çevre : 104 mm

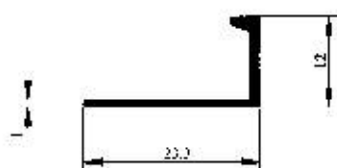

Profil No : 8009
 Gramaj : 0.108 kg/m
 Çevre : 77 mm

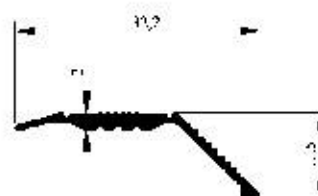

Profil No : 8041
 Gramaj : 0.129 kg/m
 Çevre : 82 mm

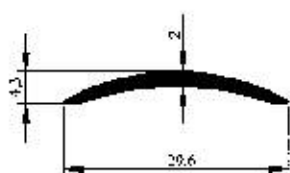

Profil No : 8016
 Gramaj : 0.136 kg/m
 Çevre : 62 mm

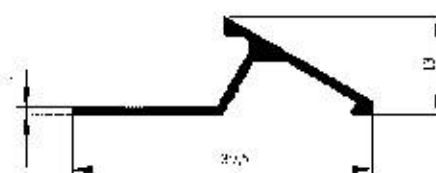

Profil No : 8040
 Gramaj : 0.173 kg/m
 Çevre : 109 mm

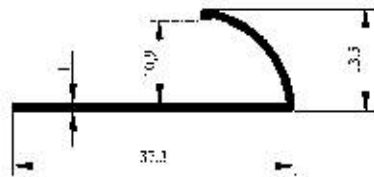

Profil No : 2846
 Gramaj : 0.152 kg/m
 Çevre : 113 mm

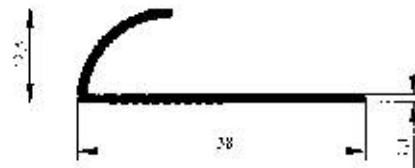

Profil No : 3009
 Gramaj : 0.174 kg/m
 Çevre : 121 mm

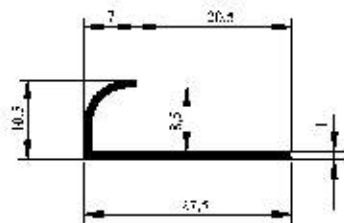

Profil No : 3951
 Gramaj : 0.110 kg/m
 Çevre : 82 mm

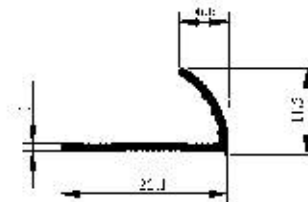

Profil No : 8010
 Gramaj : 0.089 kg/m
 Çevre : 73 mm

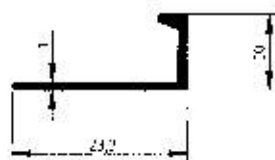

Profil No : 8011
 Gramaj : 0.101 kg/m
 Çevre : 73 mm

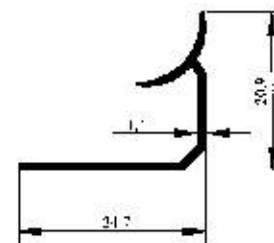

Profil No : 8012
 Gramaj : 0.142 kg/m
 Çevre : 108 mm



Profil No : 8014
 Gramaj : 0.289 kg/m
 Çevre : 170 mm

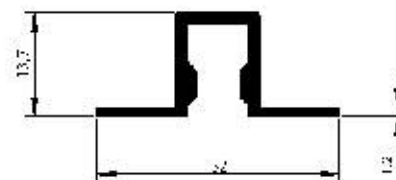

Profil No : 8020
 Gramaj : 0.239 kg/m
 Çevre : 116 mm

Stair Noising Profiles
Přechodové lišty - Obkladové lišty

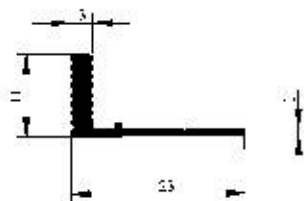

Profil No : 8031
Gramaj : 0.133 kg/m
Çevre : 76 mm

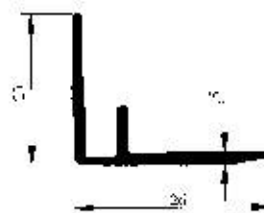

Profil No : 8029
Gramaj : 0.183 kg/m
Çevre : 109 mm



Alucomplast

Hliníkové nábytkové rámečky
Hliníkové lemovací profily

Hliníkové nábytkové rámečky
Hliníkové lemovací profily

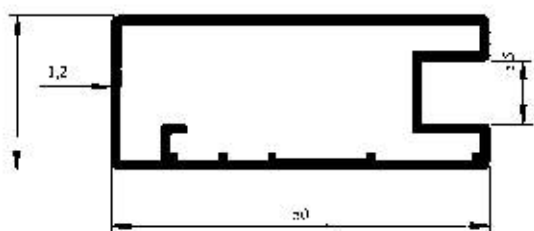

Profil No : 1906
 Gramaj : 0,539 kg/m
 Çevre : 157 mm

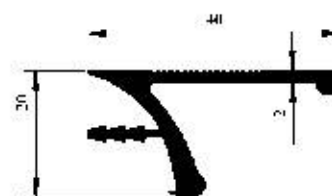

Profil No : 1907
 Gramaj : 0,446 kg/m
 Çevre : 155 mm

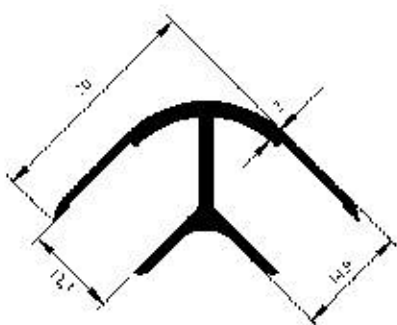

Profil No : 1908
 Gramaj : 0,370 kg/m
 Çevre : 177 mm

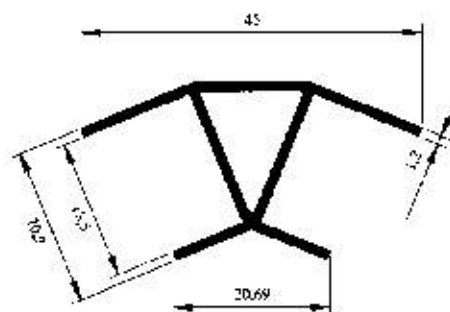

Profil No : 1909
 Gramaj : 0,377 kg/m
 Çevre : 160 mm

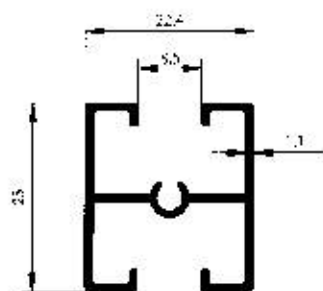

Profil No : 1910
 Gramaj : 0,307 kg/m
 Çevre : 211 mm

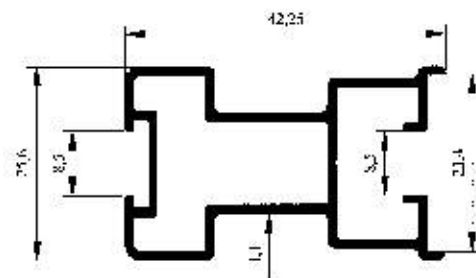

Profil No : 1911
 Gramaj : 0,496 kg/m
 Çevre : 224 mm

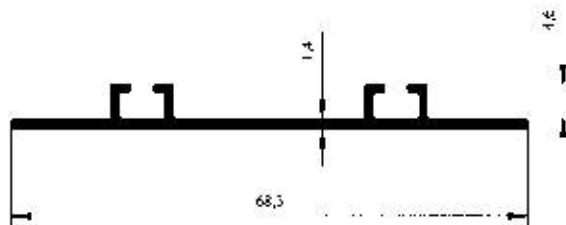

Profil No : 1912
Gramaj : 0.332 kg/m
Çevre : 183 mm

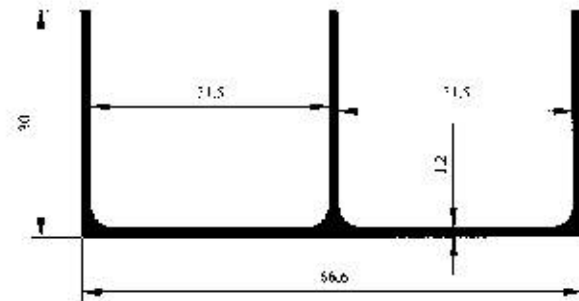

Profil No : 1913
Gramaj : 0.518 kg/m
Çevre : 302 mm

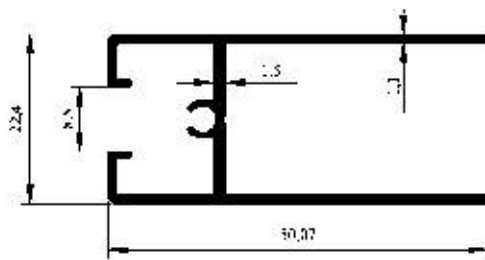

Profil No : 1914
Gramaj : 0.441 kg/m
Çevre : 282 mm

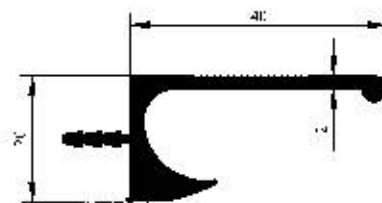

Profil No : 1915
Gramaj : 0.544 kg/m
Çevre : 166 mm

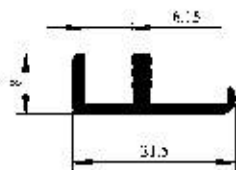

Profil No : 1923
Gramaj : 0.149 kg/m
Çevre : 76 mm

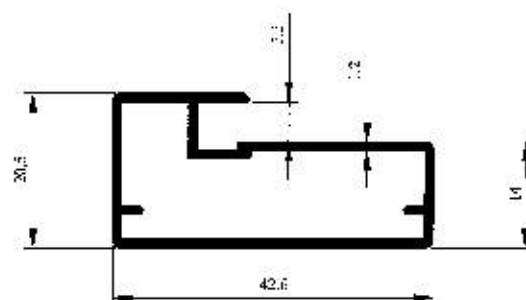

Profil No : 1930
Gramaj : 0.439 kg/m
Çevre : 139 mm

Hliníkové nábytkové rámečky
Hliníkové lemovací profily

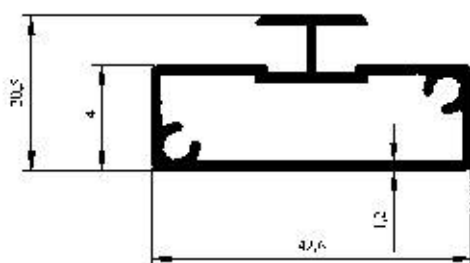

Profil No : 1931
 Gramaj : 0,481 kg/m
 Çevre : 154 mm

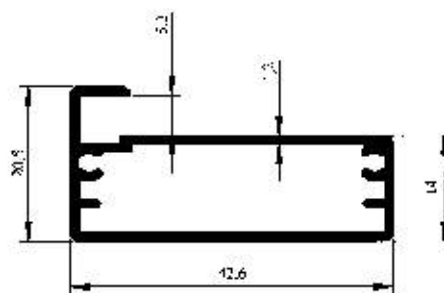

Profil No : 1932
 Gramaj : 0,447 kg/m
 Çevre : 139 mm

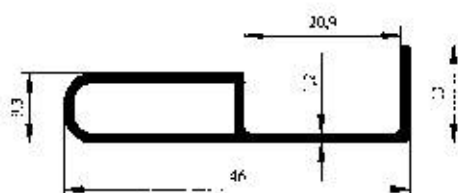

Profil No : 1933
 Gramaj : 0,302 kg/m
 Çevre : 129 mm

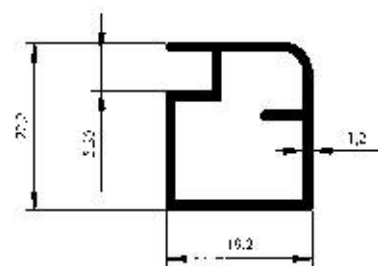

Profil No : 1934
 Gramaj : 0,285 kg/m
 Çevre : 92 mm

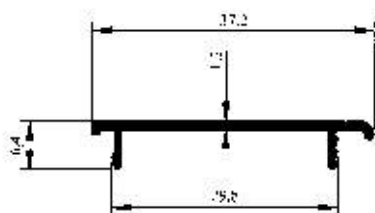

Profil No : 1935
 Gramaj : 0,154 kg/m
 Çevre : 100 mm

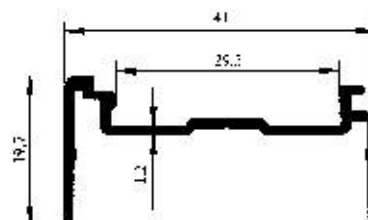

Profil No : 1936
 Gramaj : 0,284 kg/m
 Çevre : 180 mm

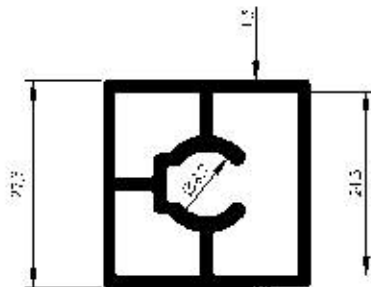

Profil No : 1937
Gramaj : 0.636 kg/m
Çevre : 108 mm

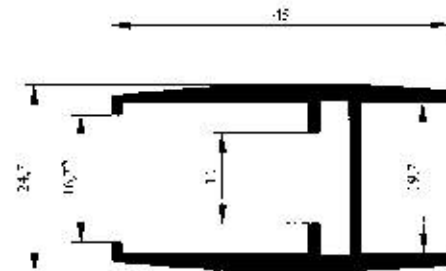

Profil No : 1958
Gramaj : 0.629 kg/m
Çevre : 242 mm

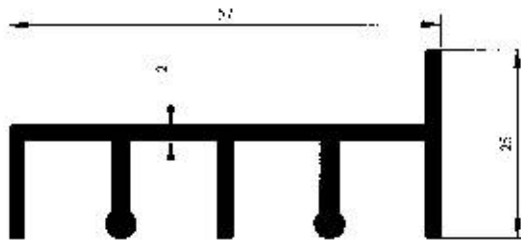

Profil No : 1959
Gramaj : 0.761 kg/m
Çevre : 268 mm



Profil No : 1972
Gramaj : 0.865 kg/m
Çevre : 78 mm



Profil No : 1973
Gramaj : 1.094 kg/m
Çevre : 184 mm

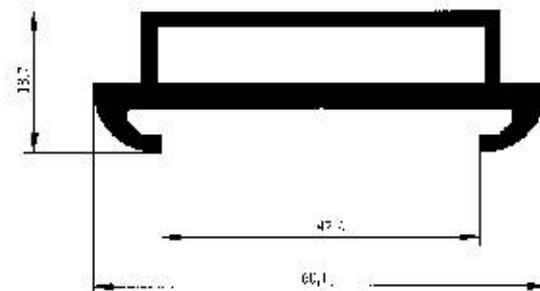

Profil No : 1974
Gramaj : 1.028 kg/m
Çevre : 178 mm

Hliníkové nábytkové rámečky
Hliníkové lemovací profily

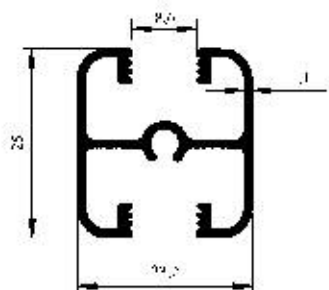

Profil No : 1984
Gramaj : 0.351 kg/m
Çevre : 230 mm

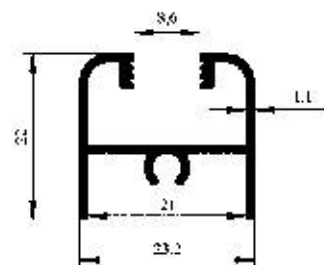

Profil No : 1985
Gramaj : 0.280 kg/m
Çevre : 185 mm

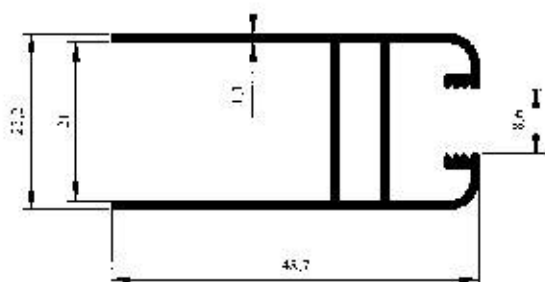

Profil No : 1986
Gramaj : 0.473 kg/m
Çevre : 263 mm

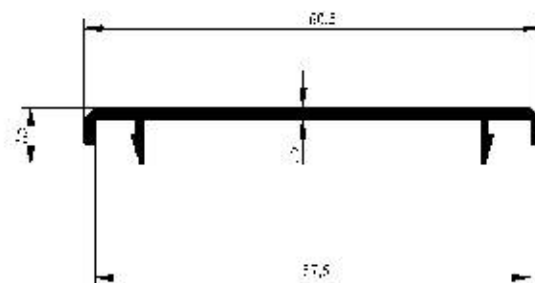

Profil No : 1987
Gramaj : 0.285 kg/m
Çevre : 152 mm

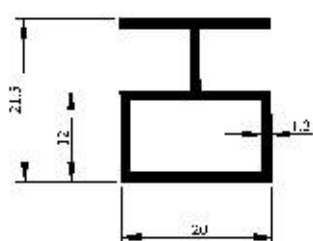

Profil No : 1988
Gramaj : 0.285 kg/m
Çevre : 121 mm

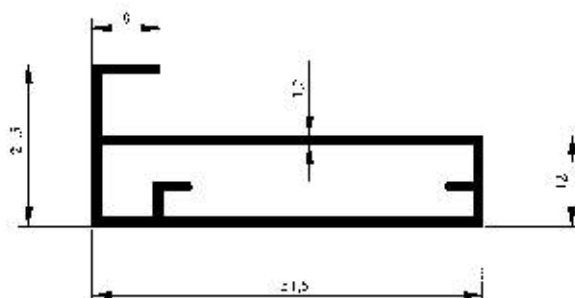

Profil No : 1992
Gramaj : 0.493 kg/m
Çevre : 161 mm

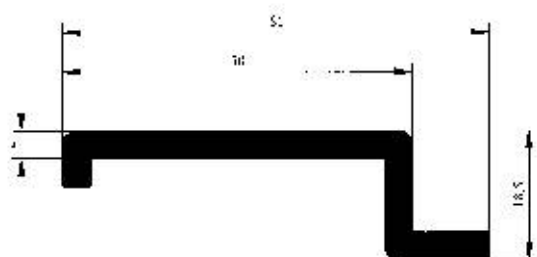

Profil No : 1993
Gramaj : 0.855 kg/m
Çevre : 164 mm

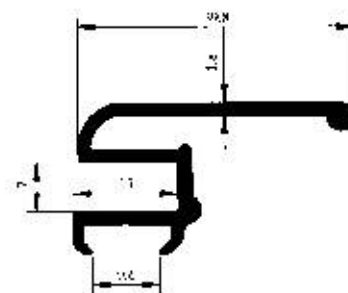

Profil No : 1996
Gramaj : 0.480 kg/m
Çevre : 189 mm

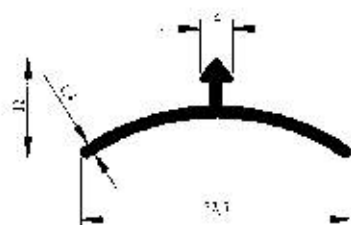

Profil No : 1997
Gramaj : 0.159 kg/m
Çevre : 84 mm

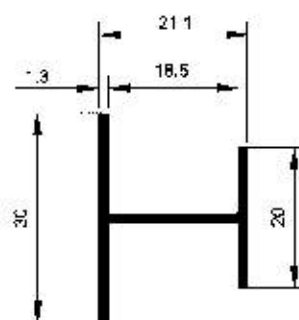

Profil No : 1999
Gramaj : 0.241 kg/m
Çevre : 140 mm

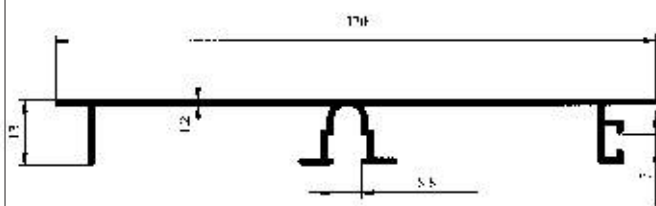

Profil No : 2204
Gramaj : 0.626 kg/m
Çevre : 381 mm

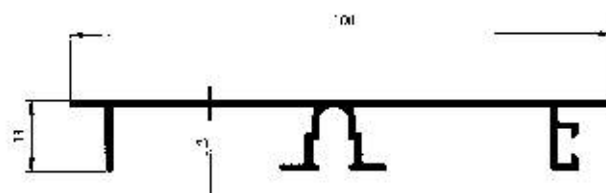

Profil No : 2205
Gramaj : 0.561 kg/m
Çevre : 341 mm

Hliníkové nábytkové rámečky
Hliníkové lemovací profily

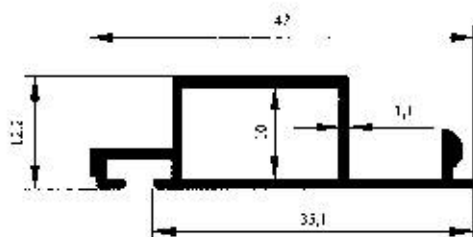

Profil No : 2206
 Gramaj : 0.296 kg/m
 Çevre : 133 mm

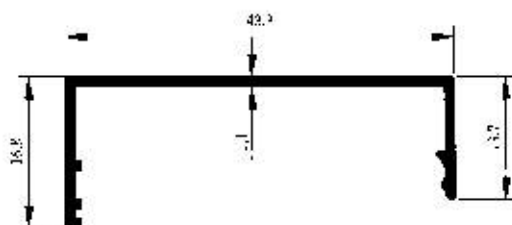

Profil No : 2207
 Gramaj : 0.223 kg/m
 Çevre : 150 mm

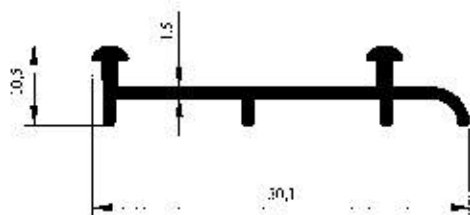

Profil No : 2210
 Gramaj : 0.328 kg/m
 Çevre : 153 mm

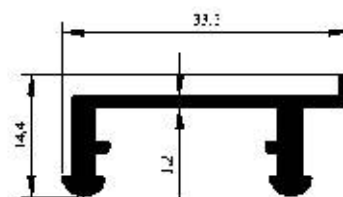

Profil No : 2211
 Gramaj : 0.307 kg/m
 Çevre : 127 mm

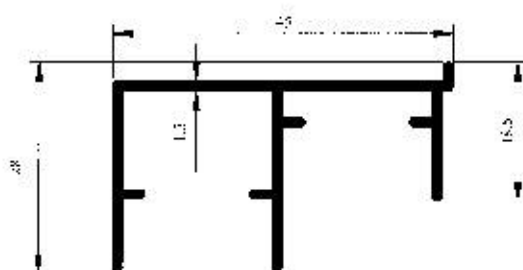

Profil No : 2212
 Gramaj : 0.428 kg/m
 Çevre : 243 mm



Profil No : 2213
 Gramaj : 0.102 kg/m
 Çevre : 37 mm

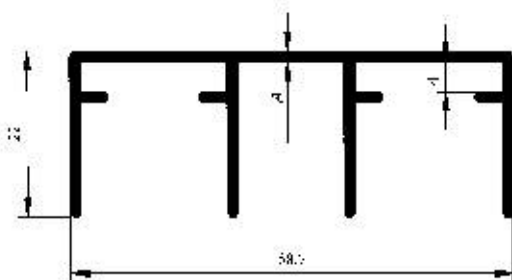

Profil No : 2214
 Gramaj : 0.586 kg/m
 Çevre : 309 mm

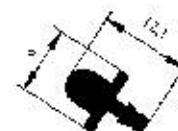

Profil No : 2215
 Gramaj : 0.126 kg/m
 Çevre : 41 mm

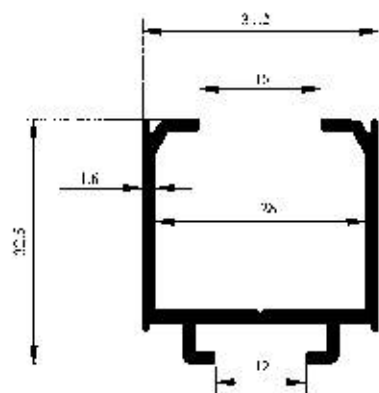

Profil No : 2216
 Gramaj : 0.483 kg/m
 Çevre : 226 mm

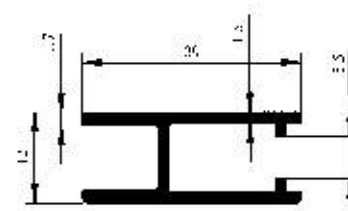

Profil No : 2220
 Gramaj : 0.294 kg/m
 Çevre : 143 mm

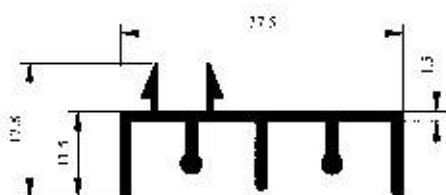

Profil No : 2221
 Gramaj : 0.379 kg/m
 Çevre : 189 mm

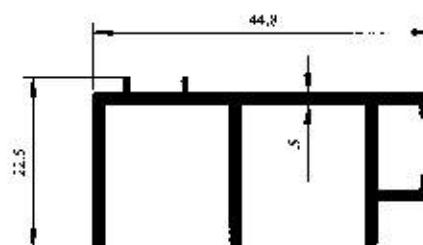

Profil No : 2222
 Gramaj : 0.464 kg/m
 Çevre : 234 mm

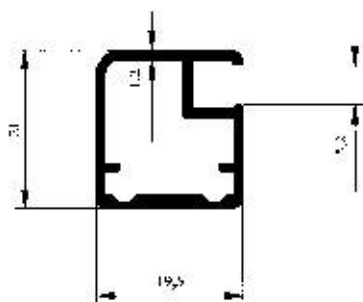

Profil No : 2224
 Gramaj : 0.296 kg/m
 Çevre : 93 mm

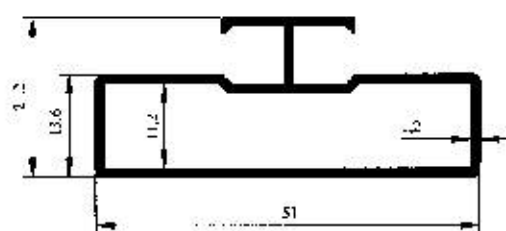

Profil No : 2231
 Gramaj : 0.492 kg/m
 Çevre : 182 mm

Hliníkové nábytkové rámečky
Hliníkové lemovací profily

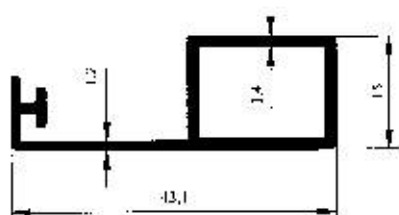

Profil No : 2235
 Gramaj : 0.369 kg/m
 Çevre : 143 mm

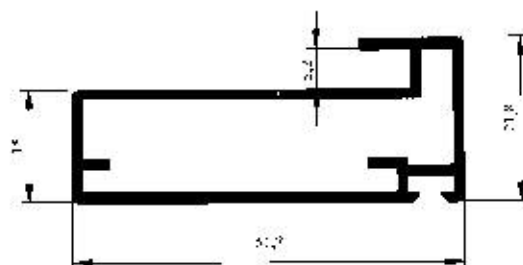

Profil No : 2236
 Gramaj : 0.575 kg/m
 Çevre : 173 mm

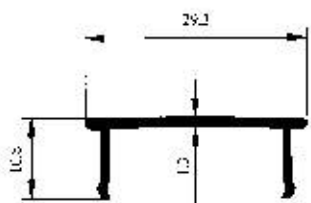

Profil No : 2241
 Gramaj : 0.155 kg/m
 Çevre : 98 mm

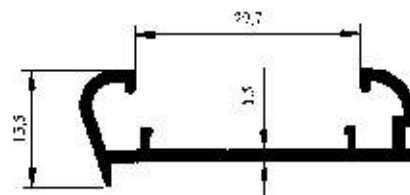

Profil No : 2242
 Gramaj : 0.439 kg/m
 Çevre : 139 mm

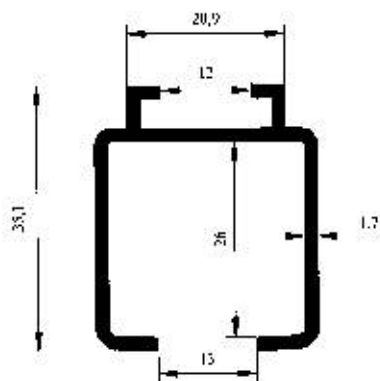

Profil No : 2251
 Gramaj : 0.513 kg/m
 Çevre : 225 mm

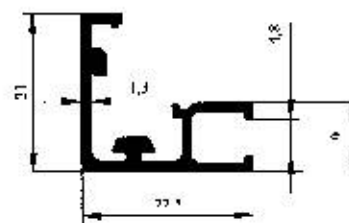

Profil No : 2253
 Gramaj : 0.273 kg/m
 Çevre : 146 mm

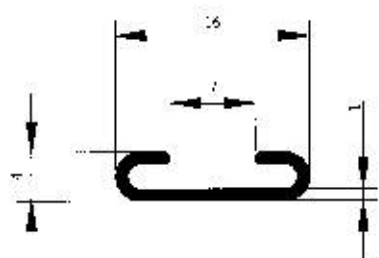

Profil No : 2254
Gramaj : 0.071 kg/m
Çevre : 54 mm

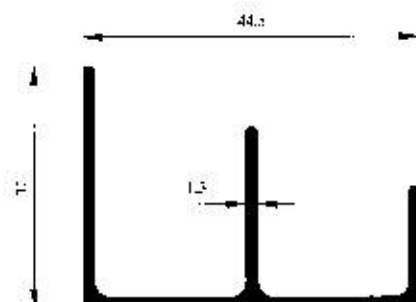

Profil No : 2266
Gramaj : 0.463 kg/m
Çevre : 221 mm

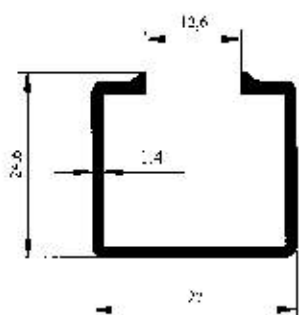

Profil No : 2267
Gramaj : 0.326 kg/m
Çevre : 168 mm

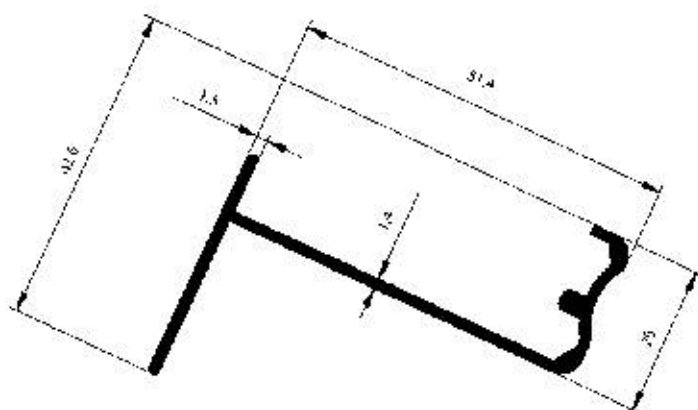

Profil No : 2268
Gramaj : 0.440 kg/m
Çevre : 214 mm

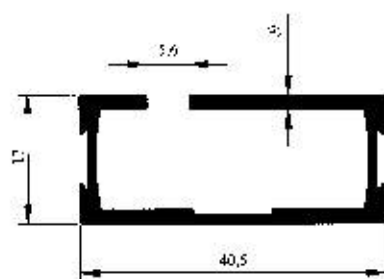

Profil No : 2269
Gramaj : 0.496 kg/m
Çevre : 211 mm

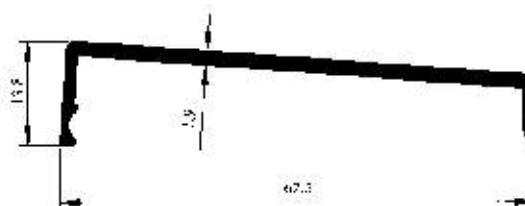

Profil No : 2270
Gramaj : 0.384 kg/m
Çevre : 166 mm

Hliníkové nábytkové rámečky
Hliníkové lemovací profily

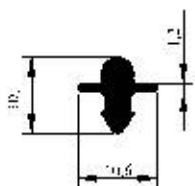

Profil No : 2282
 Gramaj : 0.115 kg/m
 Çevre : 36 mm

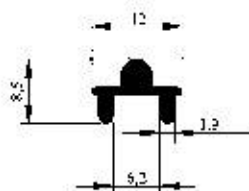

Profil No : 2283
 Gramaj : 0.110 kg/m
 Çevre : 44 mm

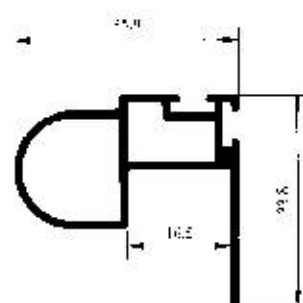

Profil No : 2630
 Gramaj : 0.453 kg/m
 Çevre : 170 mm

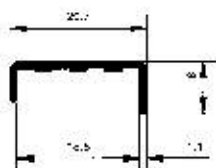

Profil No : 2631
 Gramaj : 0.106 kg/m
 Çevre : 68 mm

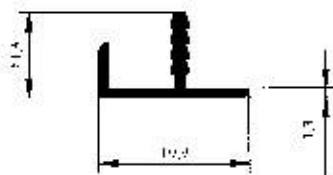

Profil No : 2655
 Gramaj : 0.141 kg/m
 Çevre : 77 mm

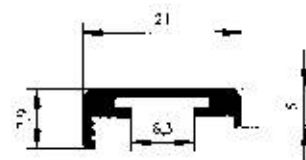

Profil No : 2659
 Gramaj : 0.148 kg/m
 Çevre : 74 mm

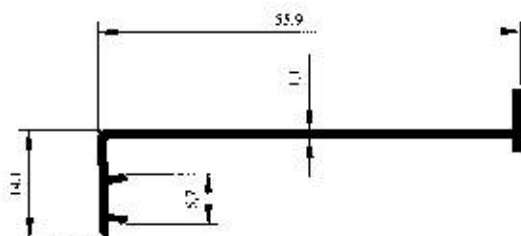

Profil No : 2666
 Gramaj : 0.238 kg/m
 Çevre : 163 mm

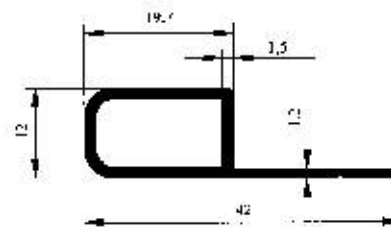

Profil No : 2667
 Gramaj : 0.293 kg/m
 Çevre : 104 mm

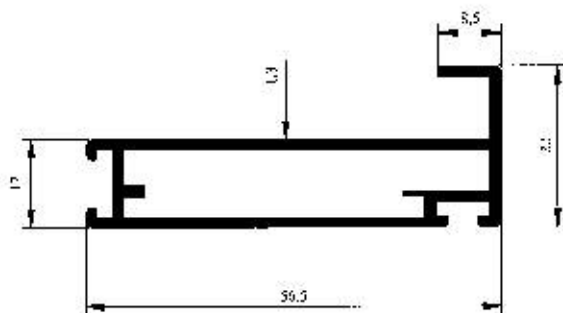

Profil No : 2668
Gramaj : 0.594 kg/m
Çevre : 195 mm

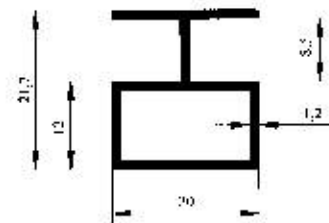

Profil No : 2669
Gramaj : 0.285 kg/m
Çevre : 121 mm

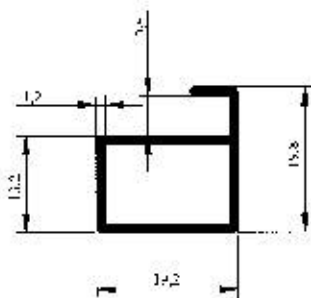

Profil No : 2670
Gramaj : 0.233 kg/m
Çevre : 87 mm

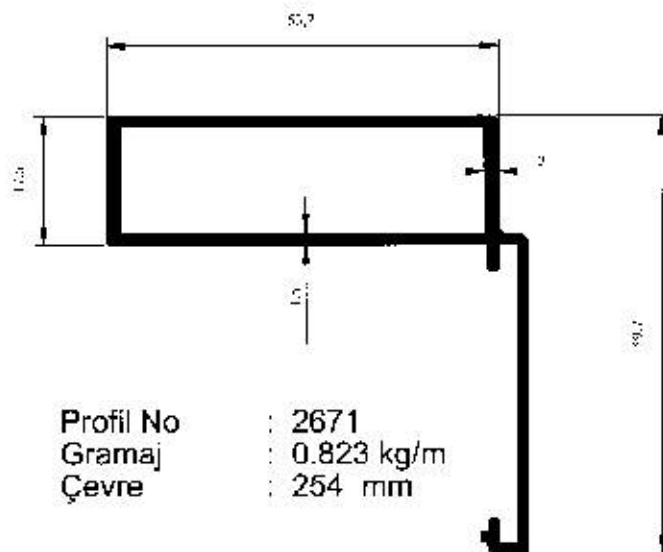

Profil No : 2671
Gramaj : 0.823 kg/m
Çevre : 254 mm

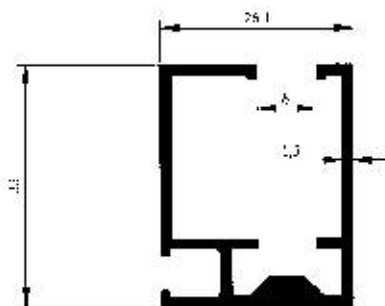

Profil No : 2692
Gramaj : 0.526 kg/m
Çevre : 246 mm

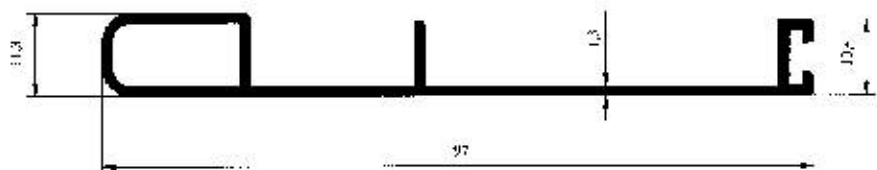

Profil No : 2693
Gramaj : 0.588 kg/m
Çevre : 260 mm

Hliníkové nábytkové rámečky
Hliníkové lemovací profily

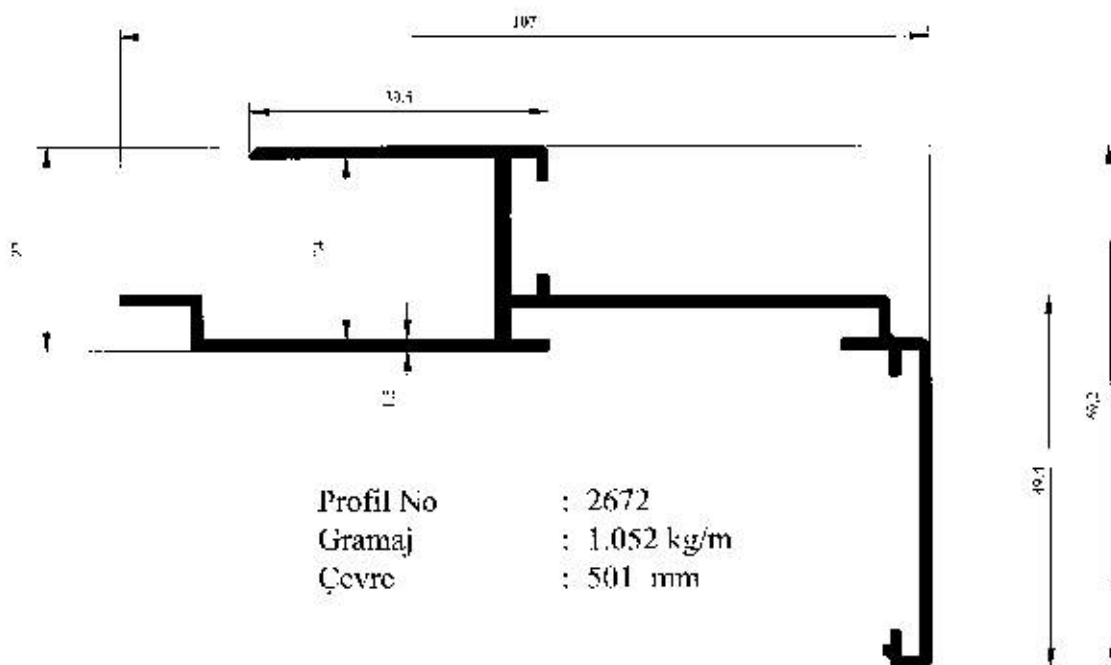

Profil No : 2672
Gramaj : 1.052 kg/m
Çevre : 501 mm

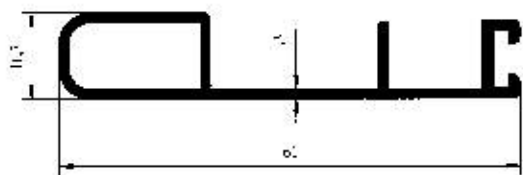

Profil No : 2694
Gramaj : 0.431 kg/m
Çevre : 188 mm

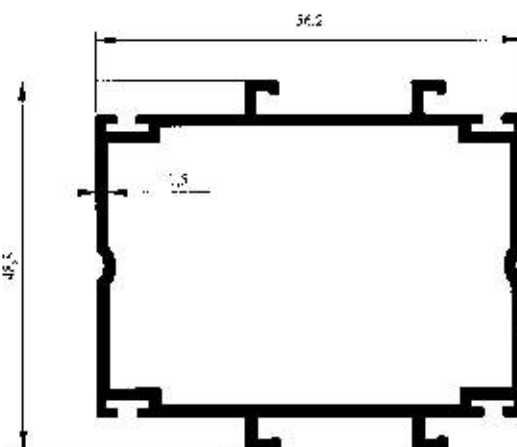

Profil No : 2695
Gramaj : 0.951 kg/m
Çevre : 297 mm

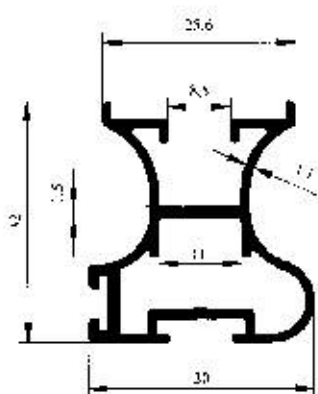

Profil No : 2698
Gramaj : 0.487 kg/m
Çevre : 200 mm

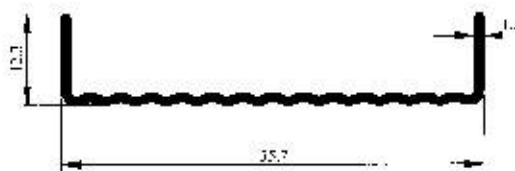

Profil No : 2734
Gramaj : 0.255 kg/m
Çevre : 168 mm

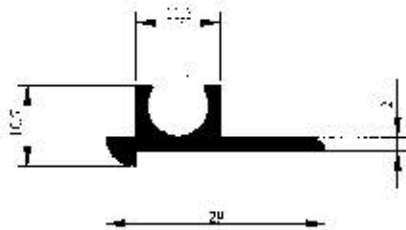

Profil No : 2765
Gramaj : 0.243 kg/m
Çevre : 88 mm

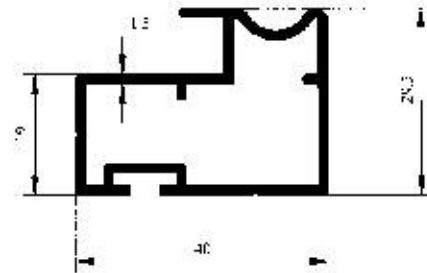

Profil No : 2841
Gramaj : 0.639 kg/m
Çevre : 170 mm

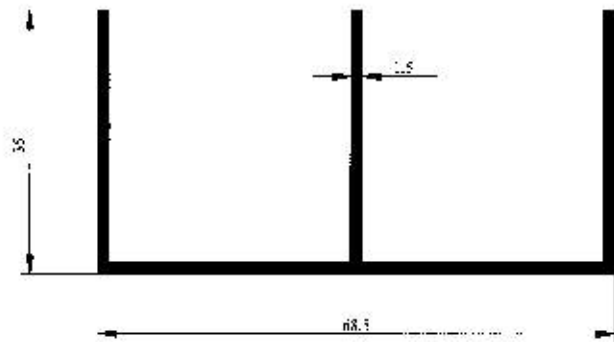

Profil No : 2842
Gramaj : 0.686 kg/m
Çevre : 341 mm



Profil No : 2843
Gramaj : 0.309 kg/m
Çevre : 143 mm

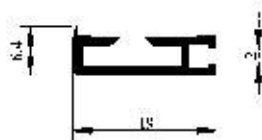

Profil No : 2854
Gramaj : 0.116 kg/m
Çevre : 86 mm

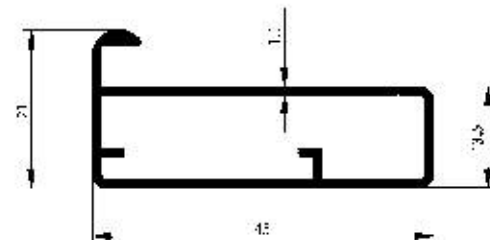

Profil No : 2858
Gramaj : 0.398 kg/m
Çevre : 137 mm

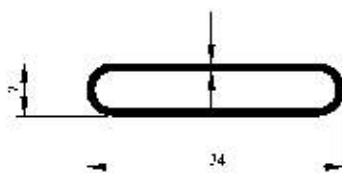

Profil No : 2867
Gramaj : 0.198 kg/m
Çevre : 76 mm

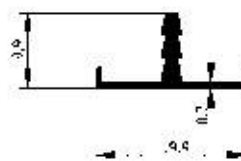

Profil No : 2889
Gramaj : 0.097 kg/m
Çevre : 68 mm

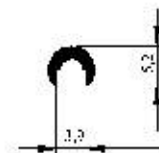

Profil No : 2892
Gramaj : 0.044 kg/m
Çevre : 25 mm

Hliníkové nábytkové rámečky
Hliníkové lemovací profily

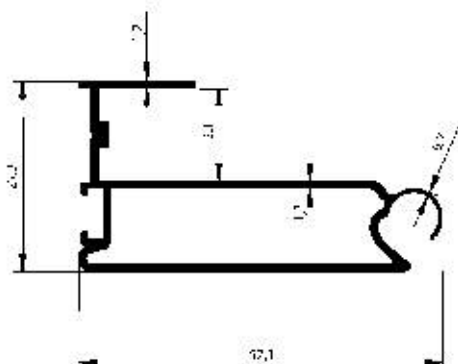

Profil No : 2911
 Gramaj : 0.525 kg/m
 Çevre : 220 mm

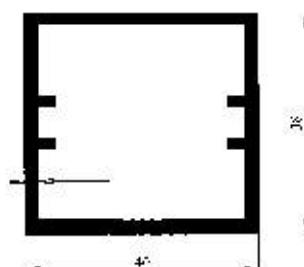

Profil No : 2954
 Gramaj : 0.972 kg/m
 Çevre : 156 mm

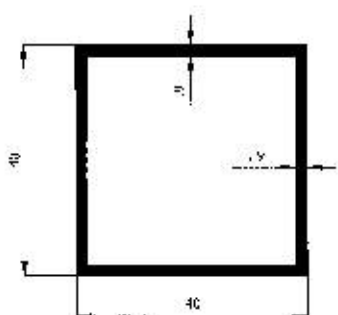

Profil No : 2955
 Gramaj : 0.781 kg/m
 Çevre : 160 mm

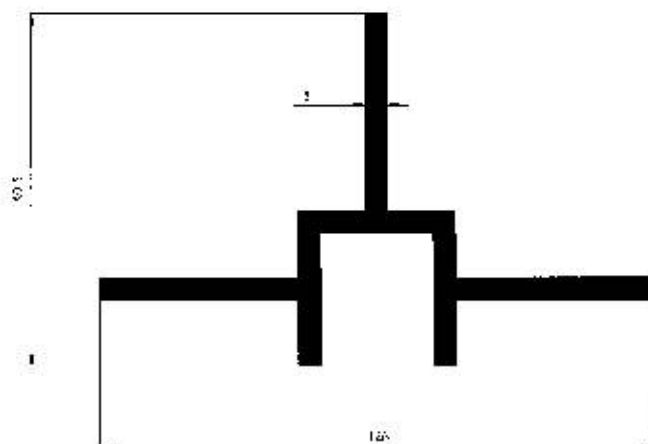

Profil No : 2956
 Gramaj : 3.143 kg/m
 Çevre : 472 mm

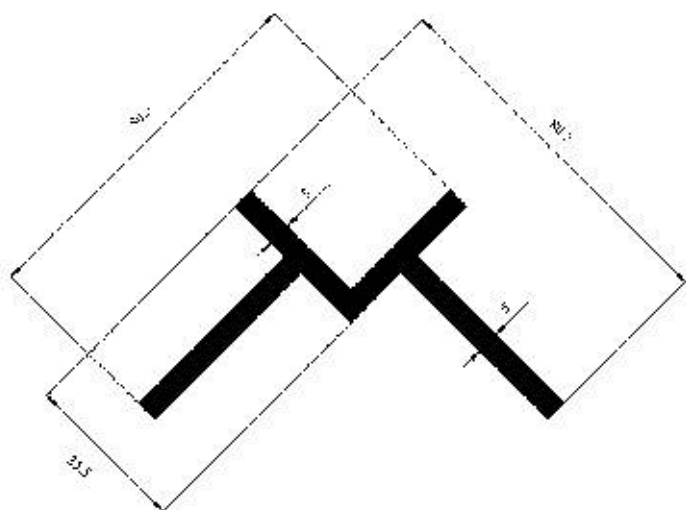

Profil No : 2957
 Gramaj : 2.118 kg/m
 Çevre : 322 mm

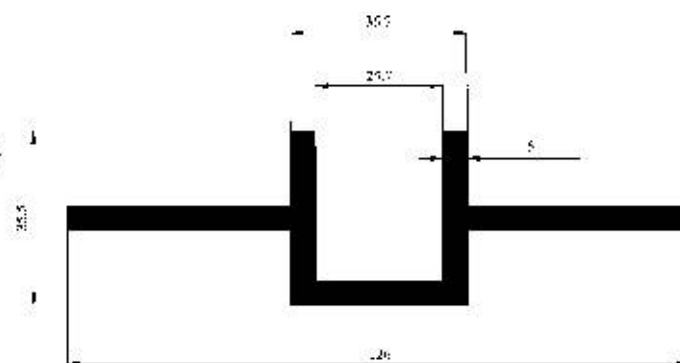

Profil No : 2958
 Gramaj : 2.533 kg/m
 Çevre : 383 mm

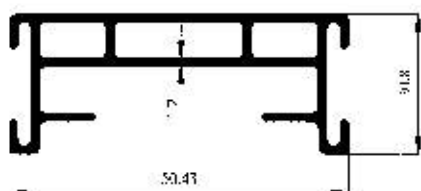

Profil No : 2974
Gramaj : 0.595 kg/m
Çevre : 239 mm

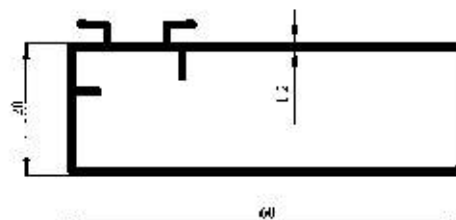

Profil No : 2975
Gramaj : 0.569 kg/m
Çevre : 186 mm

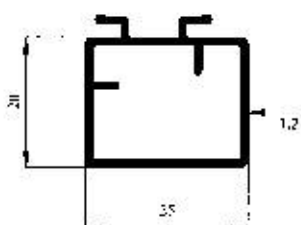

Profil No : 2976
Gramaj : 0.342 kg/m
Çevre : 116 mm

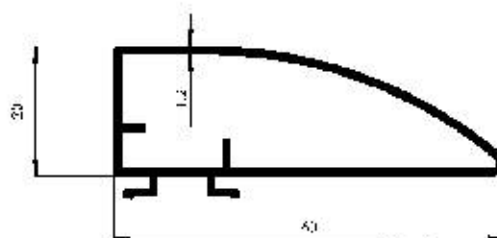

Profil No : 2977
Gramaj : 0.527 kg/m
Çevre : 173 mm

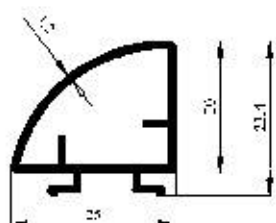

Profil No : 2978
Gramaj : 0.311 kg/m
Çevre : 107 mm

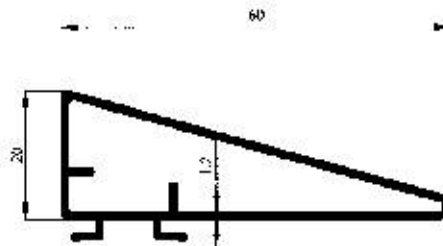

Profil No : 2979
Gramaj : 0.522 kg/m
Çevre : 172 mm

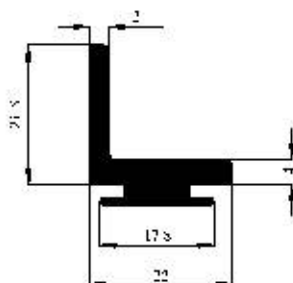

Profil No : 2980
Gramaj : 0.493 kg/m
Çevre : 106 mm

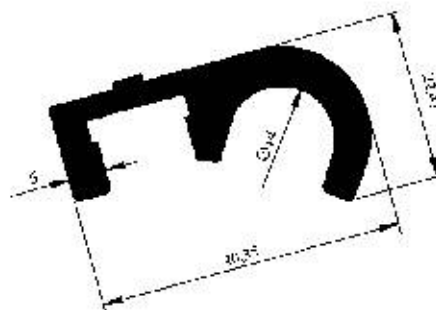

Profil No : 2981
Gramaj : 0.876 kg/m
Çevre : 151 mm

Hliníkové nábytkové rámečky
Hliníkové lemovací profily

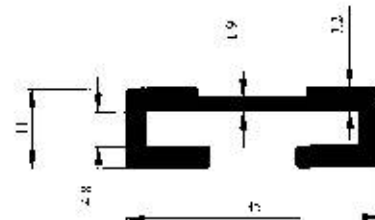
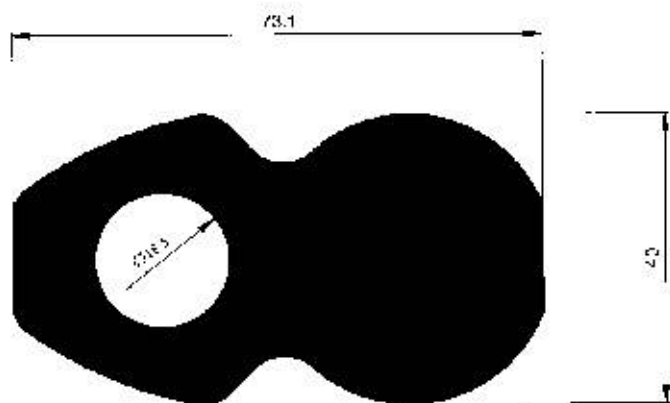

Profil No : 3026
 Gramaj : 0.509 kg/m
 Çevre : 150 mm

Profil No : 3025
 Gramaj : 5.761 kg/m
 Çevre : 201 mm

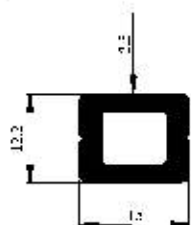

Profil No : 3027
 Gramaj : 0.399 kg/m
 Çevre : 176 mm

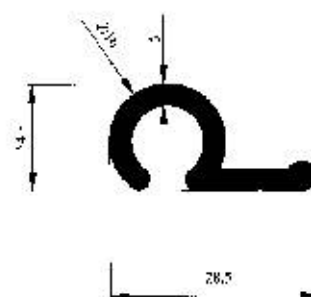

Profil No : 3028
 Gramaj : 0.406 kg/m
 Çevre : 102 mm

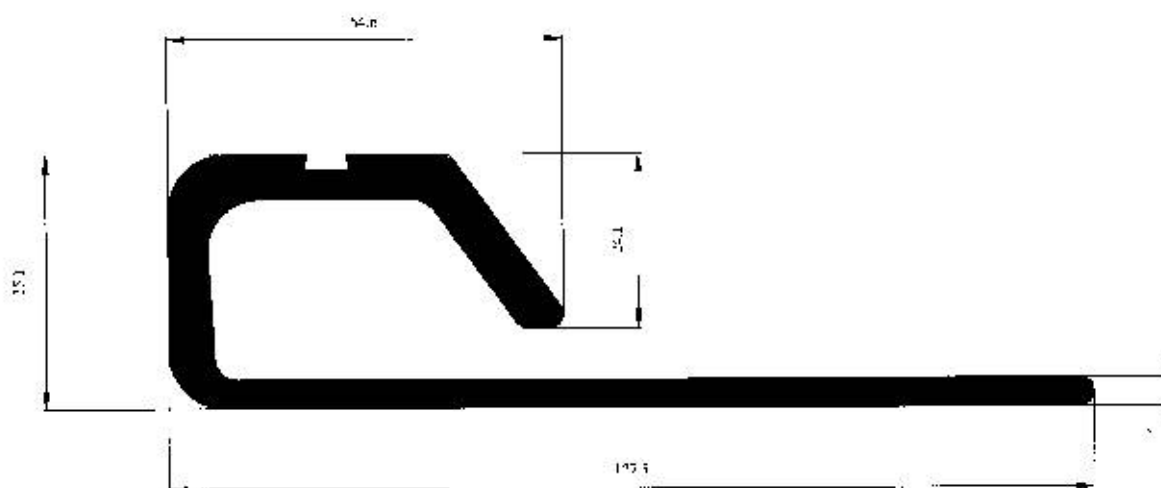

Profil No : 3029
 Gramaj : 2.770 kg/m
 Çevre : 429 mm

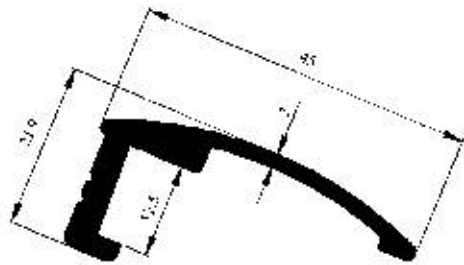

Profil No : 3030
Gramaj : 0.527 kg/m
Çevre : 133 mm

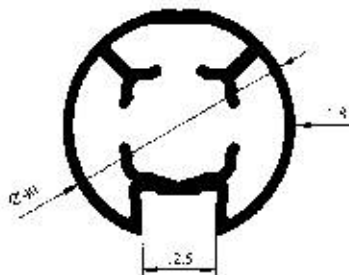

Profil No : 3032
Gramaj : 0.940 kg/m
Çevre : 142 mm

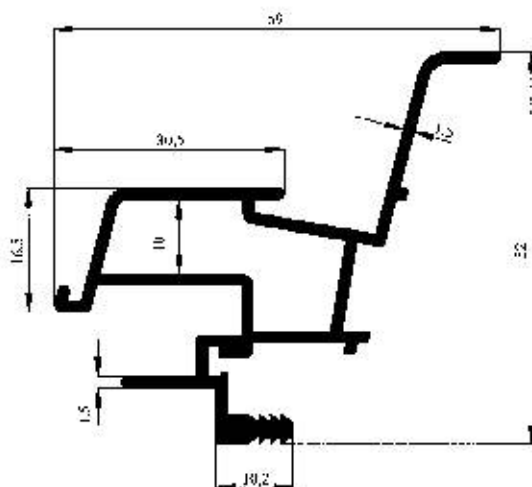

Profil No : 3071
Gramaj : 0.369 kg/m
Çevre : 118 mm

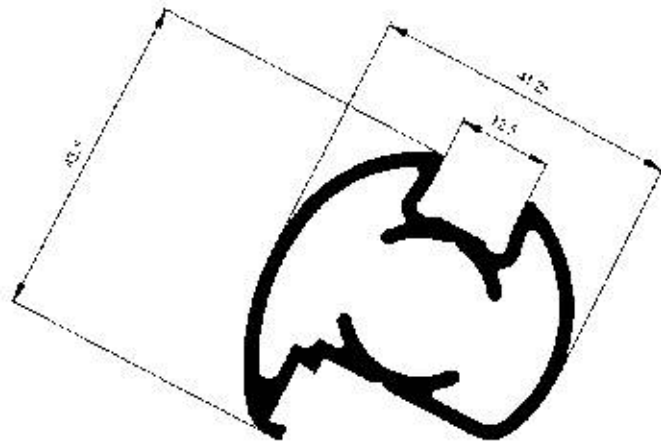

Profil No : 3031
Gramaj : 0.923 kg/m
Çevre : 167 mm

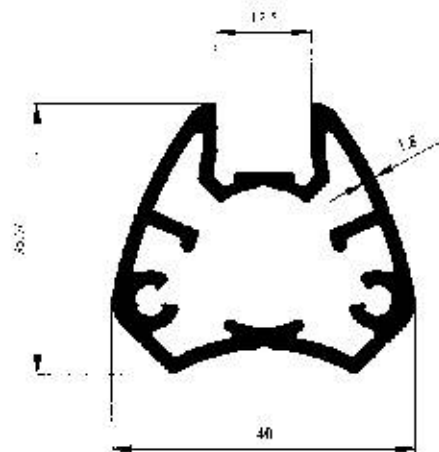

Profil No : 3033
Gramaj : 0.946 kg/m
Çevre : 150 mm

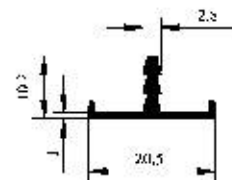

Profil No : 3177
Gramaj : 0.119 kg/m
Çevre : 70 mm

Hliníkové nábytkové rámečky
Hliníkové lemovací profily



Profil No : 3182
Gramaj : 0.735kg/m
Çevre : 193 mm



Profil No : 3293
Gramaj : 0.444 kg/m
Çevre : 184 mm

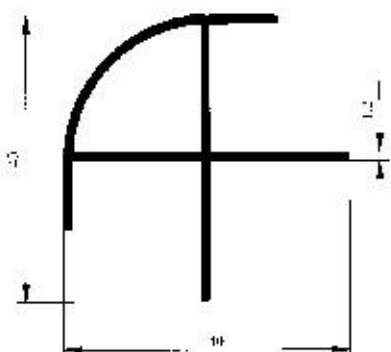

Profil No : 3799
Gramaj : 0.410 kg/m
Çevre : 188 mm

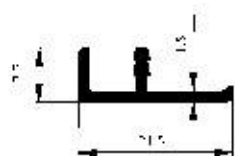

Profil No : 3965
Gramaj : 0.142 kg/m
Çevre : 71 mm

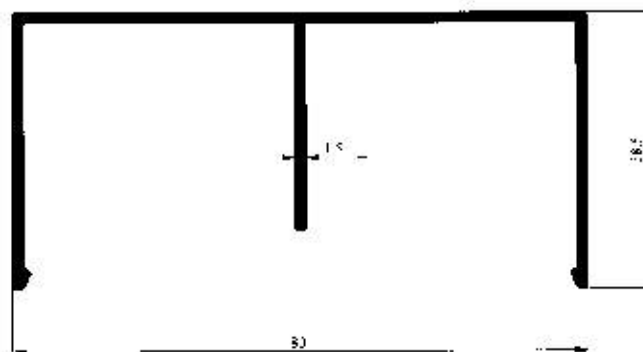

Profil No : 3292
Gramaj : 0.751 kg/m
Çevre : 369 mm

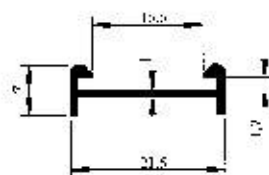

Profil No : 3601
Gramaj : 0.105 kg/m
Çevre : 75 mm

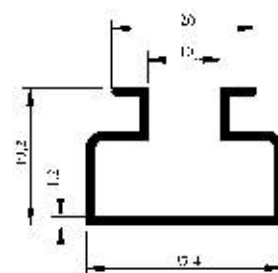

Profil No : 3800
Gramaj : 0.274 kg/m
Çevre : 170 mm

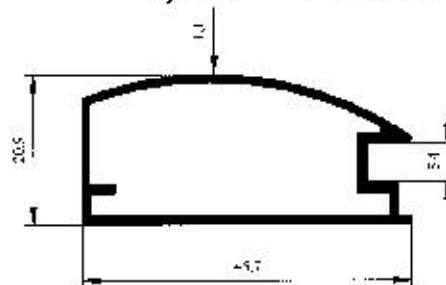

Profil No : 3980
Gramaj : 0.428 kg/m
Çevre : 135 mm

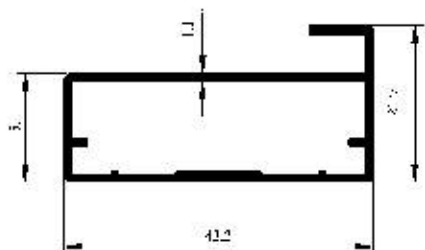

Profil No : 3982
Gramaj : 0.414 kg/m
Çevre : 144 mm

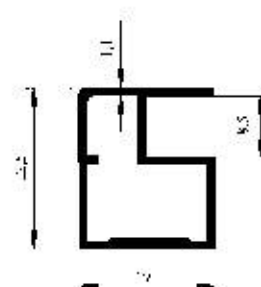

Profil No : 3983
Gramaj : 0.276 kg/m
Çevre : 101 mm

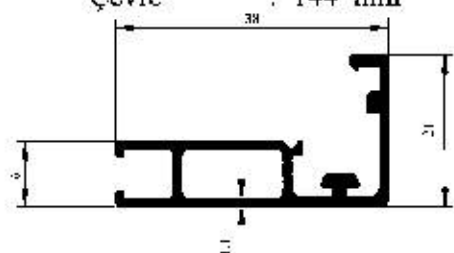

Profil No : 3984
Gramaj : 0.385 kg/m
Çevre : 177 mm

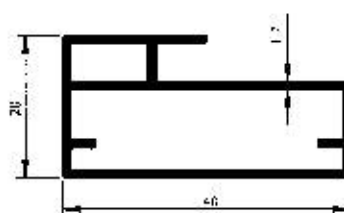

Profil No : 3999
Gramaj : 0.454 kg/m
Çevre : 133 mm

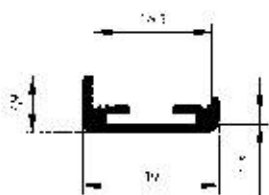

Profil No : 4053
Gramaj : 0.134 kg/m
Çevre : 74 mm

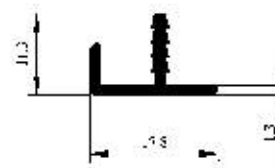

Profil No : 4054
Gramaj : 0.133 kg/m
Çevre : 73 mm

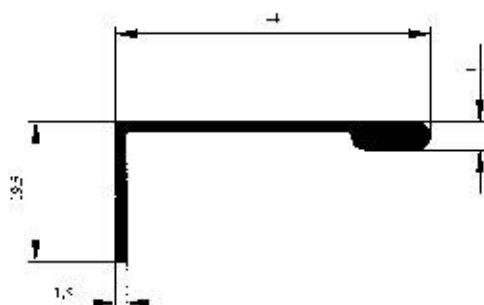

Profil No : 4066
Gramaj : 0.319 kg/m
Çevre : 129 mm

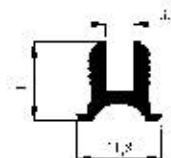

Profil No : 4067
Gramaj : 0.136 kg/m
Çevre : 64 mm

Hliníkové nábytkové rámečky
Hliníkové lemovací profily

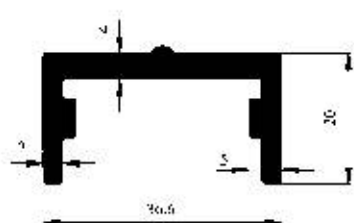

Profil No : 4092
 Gramaj : 0.729 kg/m
 Çevre : 150 mm

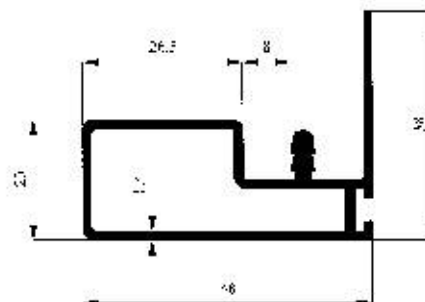

Profil No : 4100
 Gramaj : 0.676 kg/m
 Çevre : 220 mm

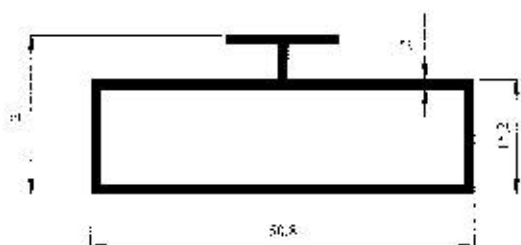

Profil No : 4102
 Gramaj : 0.478 kg/m
 Çevre : 171 mm

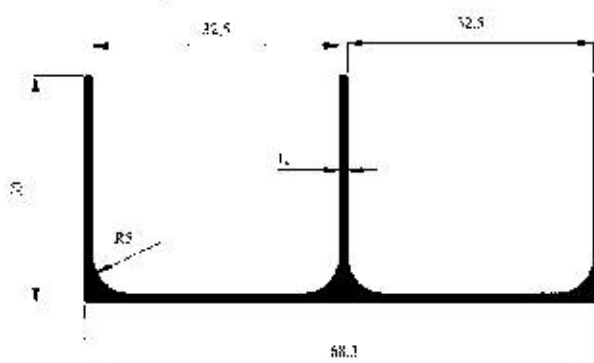

Profil No : 4114
 Gramaj : 0.520 kg/m
 Çevre : 303 mm

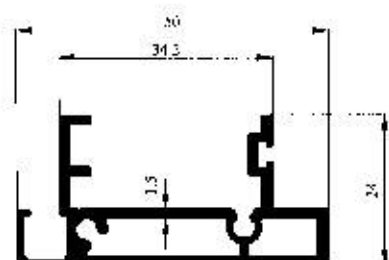

Profil No : 4148
 Gramaj : 0.683 kg/m
 Çevre : 230 mm

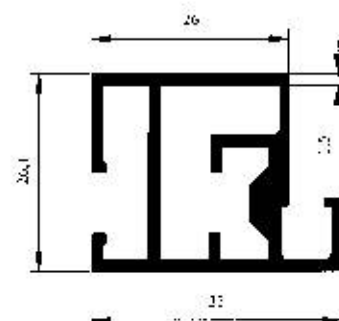

Profil No : 4149
 Gramaj : 0.650 kg/m
 Çevre : 182 mm

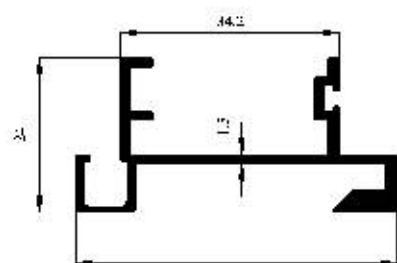

Profil No : 4150
 Gramaj : 0.531 kg/m
 Çevre : 249 mm

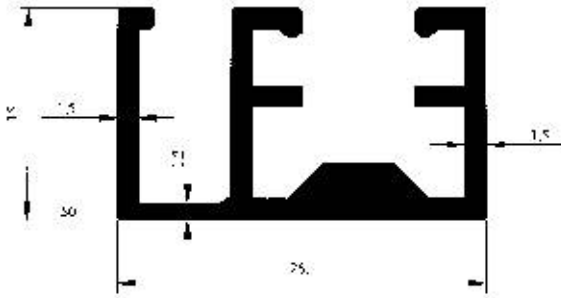

Profil No : 4157
Gramaj : 0.381 kg/m
Çevre : 168 mm

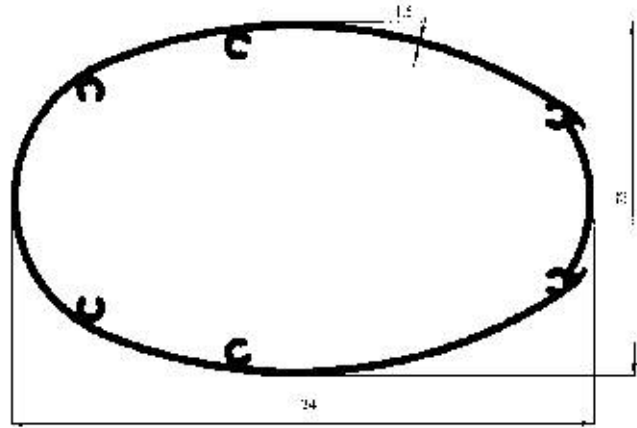

Profil No : 4175
Gramaj : 1.585 kg/m
Çevre : 335 mm

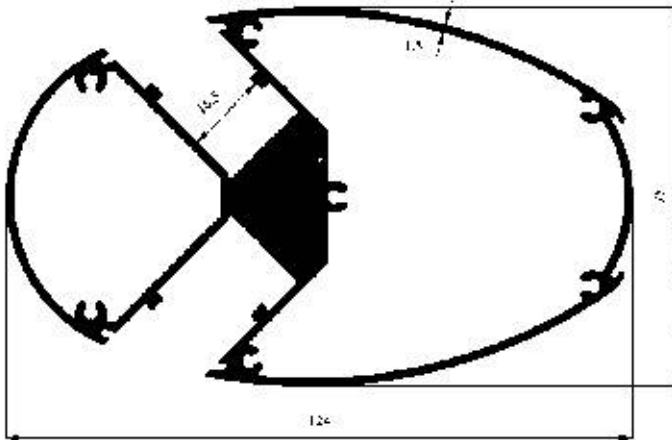

Profil No : 4176
Gramaj : 2.366 kg/m
Çevre : 496 mm



Profil No : 4177
Gramaj : 0.107 kg/m
Çevre : 57 mm

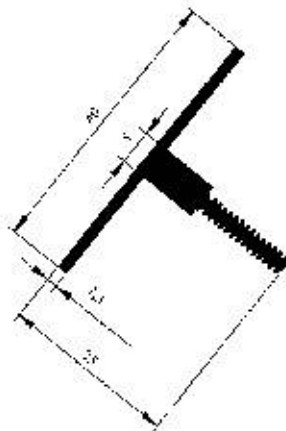

Profil No : 4272
Gramaj : 0.371 kg/m
Çevre : 155 mm

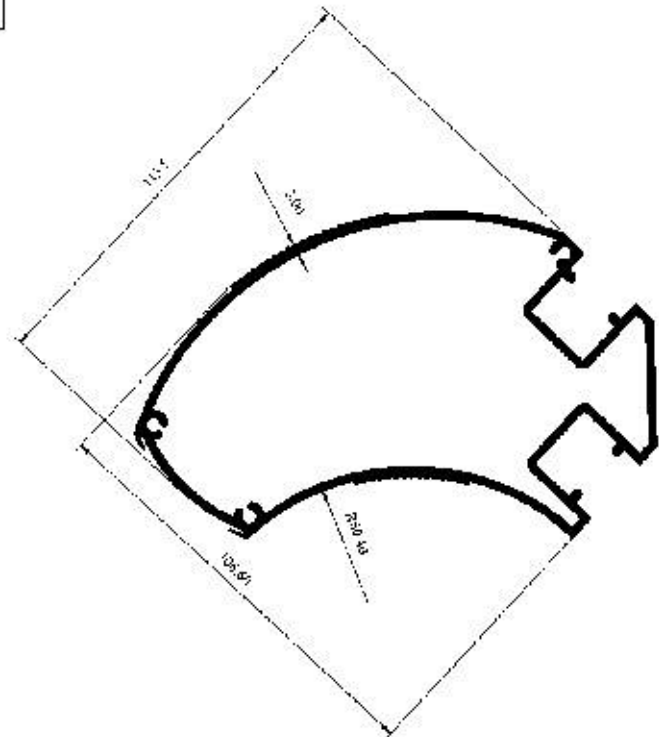

Profil No : 4424
Gramaj : 2.705 kg/m
Çevre : 485 mm

Hliníkové nábytkové rámečky
Hliníkové lemovací profily

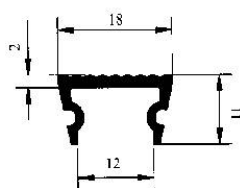

Profil No : 4425
 Gramaj : 0.168 kg/m
 Çevre : 84 mm

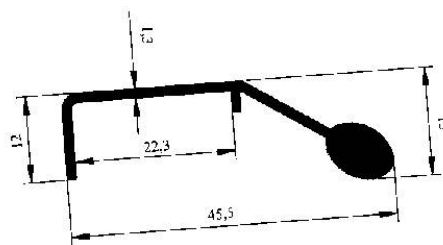

Profil No : 4432
 Gramaj : 0.331 kg/m
 Çevre : 134 mm

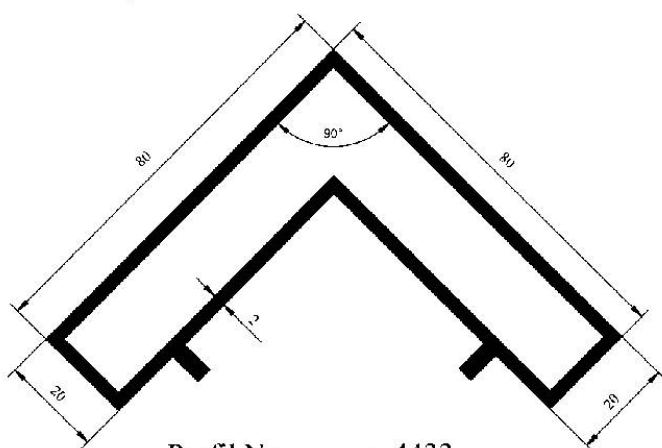

Profil No : 4433
 Gramaj : 1.816 kg/m
 Çevre : 375 mm

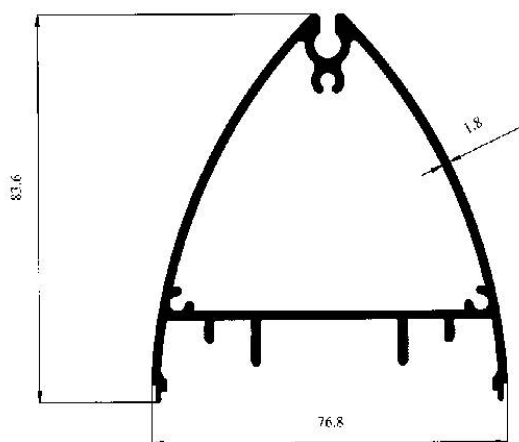

Profil No : 4437
 Gramaj : 1.646 kg/m
 Çevre : 387 mm

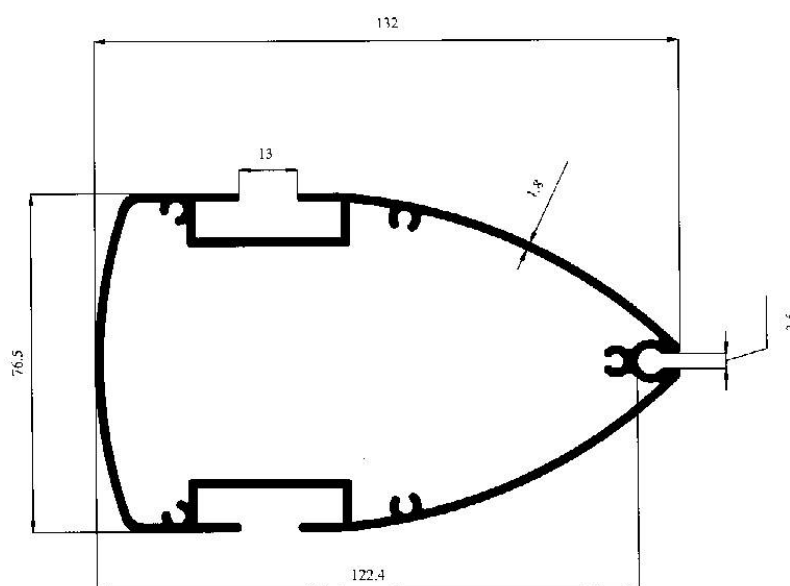

Profil No : 4436
 Gramaj : 2.407 kg/m
 Çevre : 488 mm

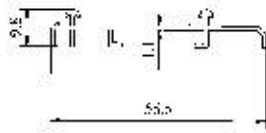

Profil No : 4490
Gramaj : 0.292 kg/m
Çevre : 194 mm



Profil No : 4491
Gramaj : 0.493 kg/m
Çevre : 317 mm

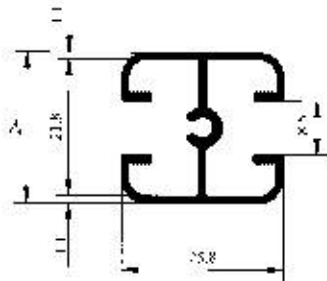

Profil No : 4492
Gramaj : 0.370 kg/m
Çevre : 234 mm

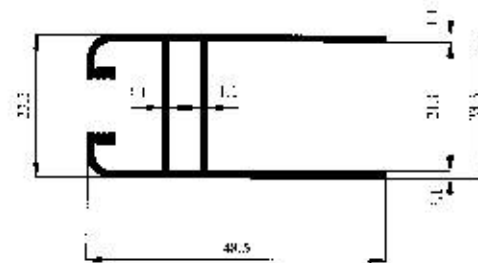

Profil No : 4493
Gramaj : 0.476 kg/m
Çevre : 263 mm

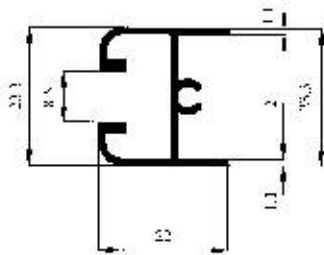

Profil No : 4494
Gramaj : 0.285 kg/m
Çevre : 185 mm

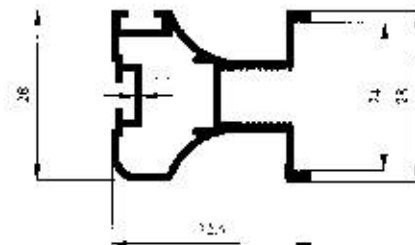

Profil No : 4495
Gramaj : 0.469 kg/m
Çevre : 205 mm

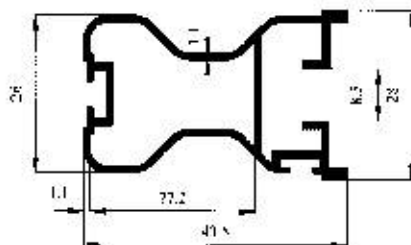

Profil No : 4496
Gramaj : 0.554 kg/m
Çevre : 246 mm

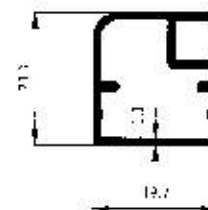

Profil No : 4497
Gramaj : 0.274 kg/m
Çevre : 94 mm

Hliníkové nábytkové rámečky
Hliníkové lemovací profily

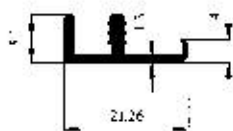

Profil No : 4498
 Gramaj : 0.150 kg/m
 Çevre : 79 mm

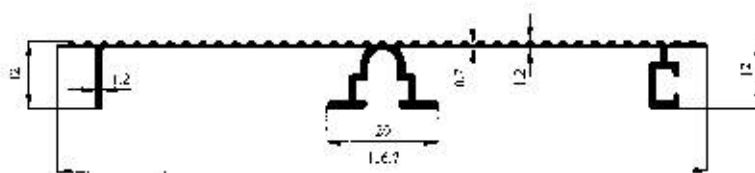

Profil No : 4499
 Gramaj : 0.522 kg/m
 Çevre : 383 mm

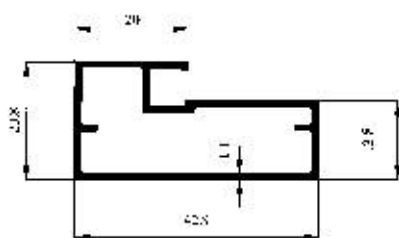

Profil No : 4500
 Gramaj : 0.416 kg/m
 Çevre : 142 mm

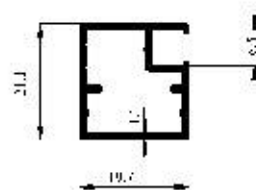

Profil No : 4501
 Gramaj : 0.278 kg/m
 Çevre : 96 mm

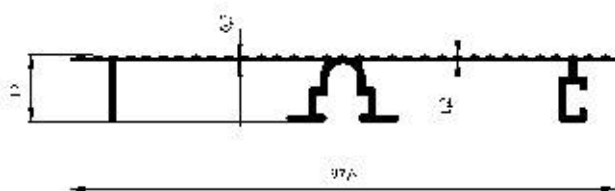

Profil No : 4502
 Gramaj : 0.472 kg/m
 Çevre : 340 mm

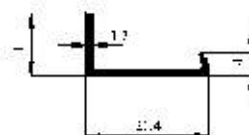

Profil No : 4503
 Gramaj : 0.105 kg/m
 Çevre : 68 mm

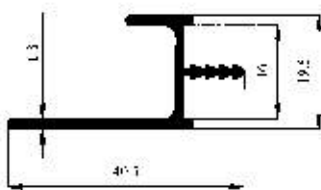

Profil No : 4562
 Gramaj : 0.318 kg/m
 Çevre : 145 mm

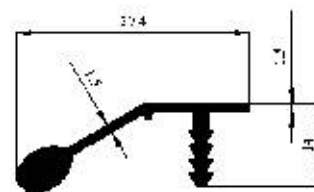

Profil No : 4563
 Gramaj : 0.378 kg/m
 Çevre : 129 mm

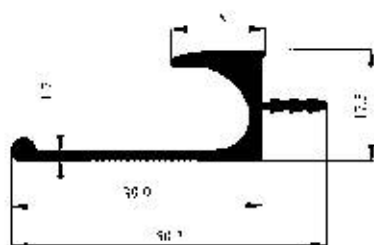

Profil No : 4564
Gramaj : 0.456 kg/m
Çevre : 163 mm

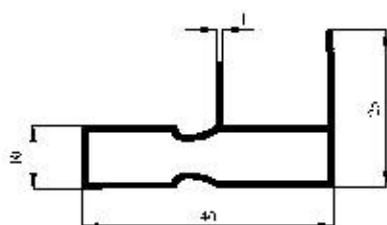

Profil No : 4566
Gramaj : 0.333 kg/m
Çevre : 152 mm

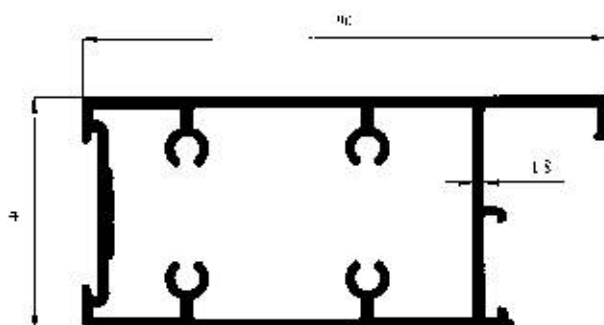

Profil No : 4573
Gramaj : 1.599 kg/m
Çevre : 303 mm

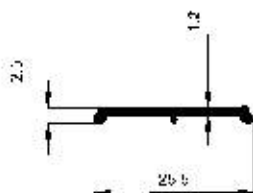

Profil No : 4575
Gramaj : 0.095 kg/m
Çevre : 58 mm

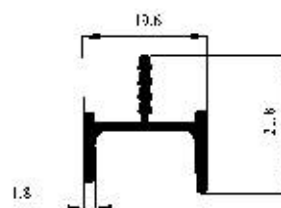

Profil No : 4565
Gramaj : 0.225 kg/m
Çevre : 107 mm

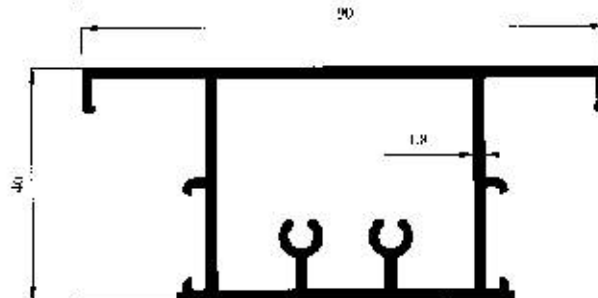

Profil No : 4572
Gramaj : 1.354 kg/m
Çevre : 327 mm

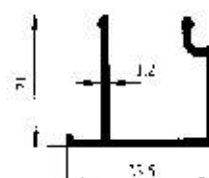

Profil No : 4574
Gramaj : 0.220 kg/m
Çevre : 136 mm





Alucomplast

**Hliníkové Profily, Dělicí Příčky,
Hliníkové profily pro interiérové dělicí příčky**

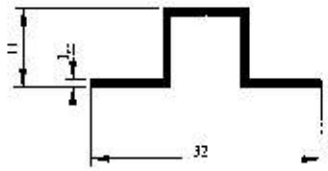

Profil No : 2794
Gramaj : 0.154 kg/m
Çevre : 106 mm

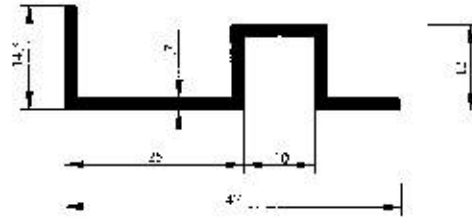

Profil No : 3019
Gramaj : 0.370 kg/m
Çevre : 163 mm

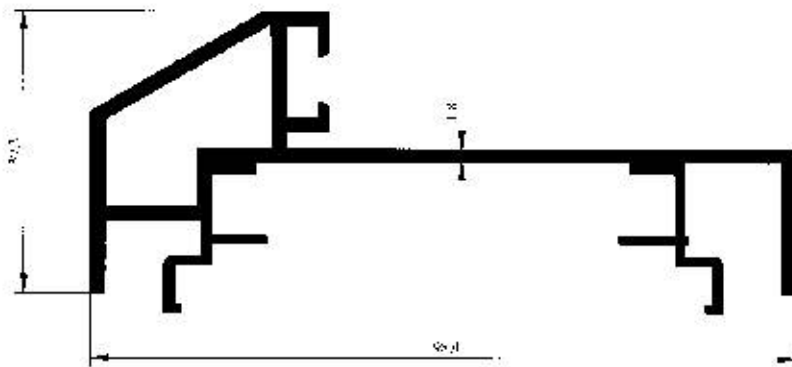

Profil No : 2939
Gramaj : 1.366 kg/m
Çevre : 469 mm

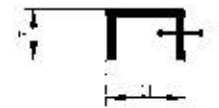

Profil No : 3865
Gramaj : 0.064 kg/m
Çevre : 172 mm

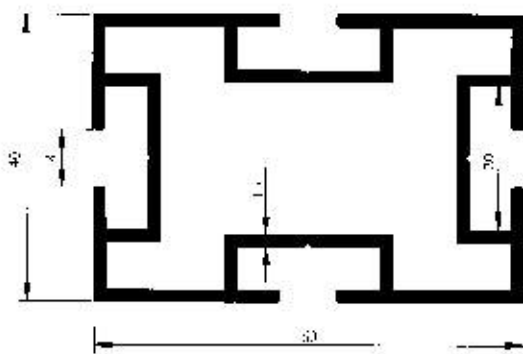

Profil No : 3148
Gramaj : 1.391 kg/m
Çevre : 357 mm

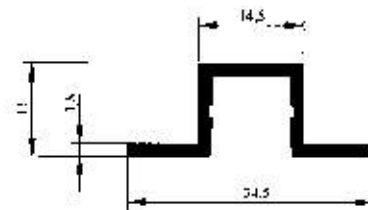

Profil No : 3866
Gramaj : 0.269 kg/m
Çevre : 118 mm

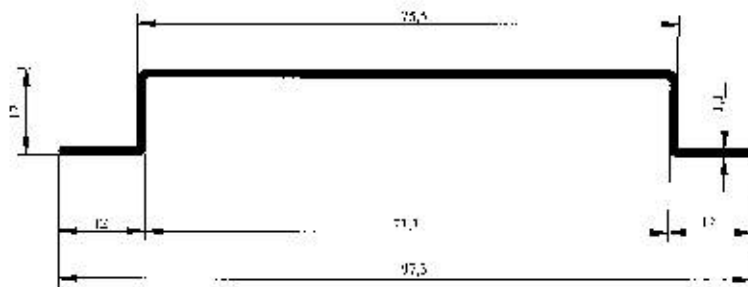

Profil No : 3867
Gramaj : 0.352 kg/m
Çevre : 236 mm

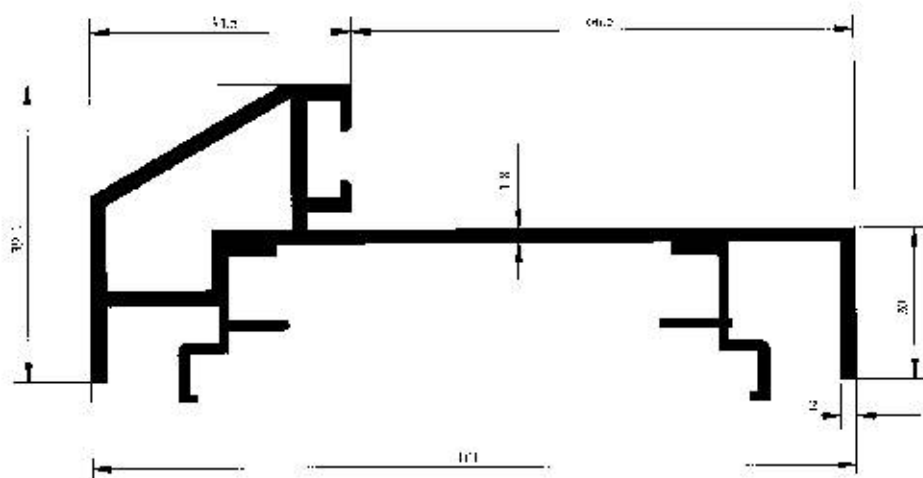

Profil No : 3868
Gramaj : 1.371 kg/m
Çevre : 473 mm

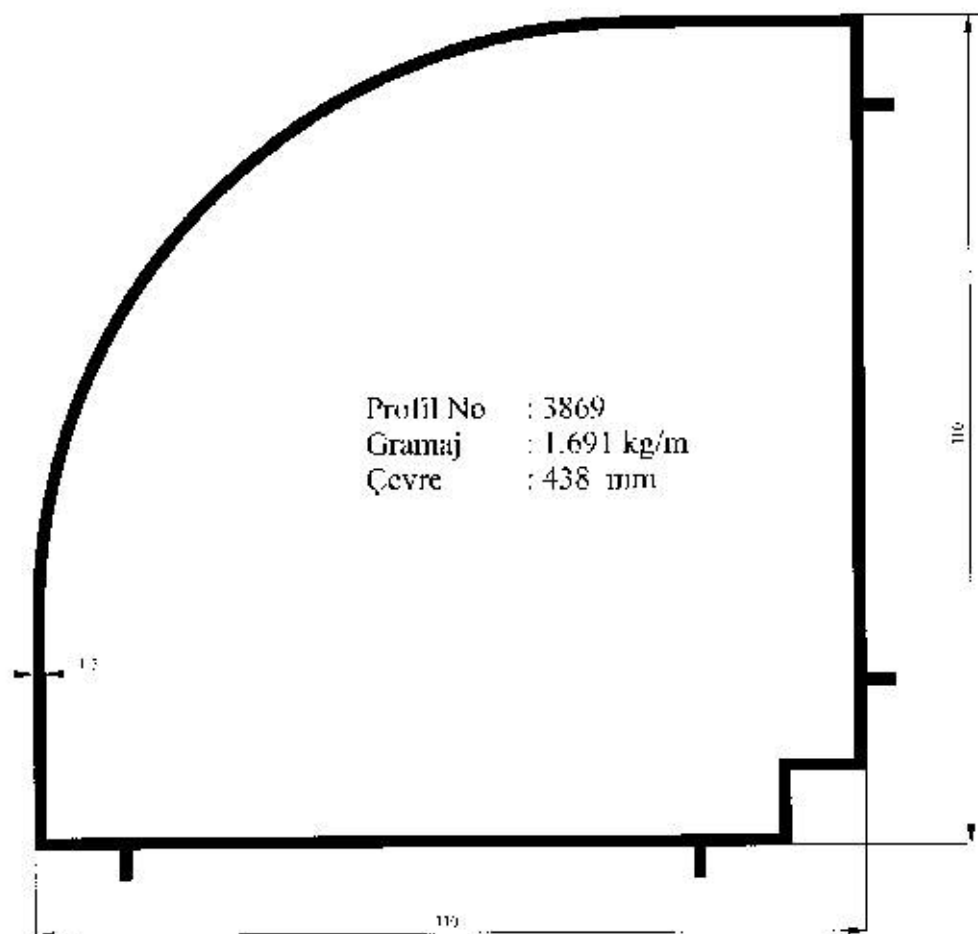

Profil No : 3869
Gramaj : 1.691 kg/m
Çevre : 438 mm

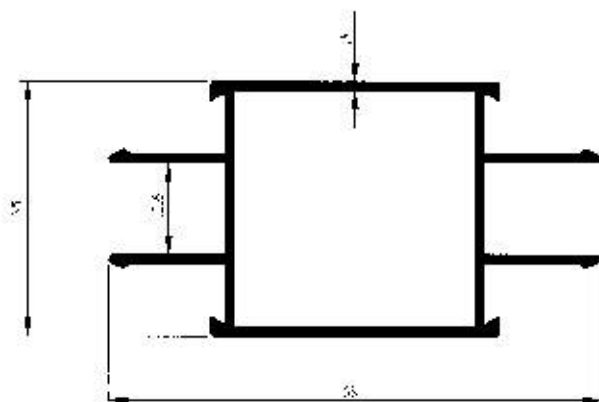

Profil No : 4004
Gramaj : 0.743 kg/m
Çevre : 291 mm

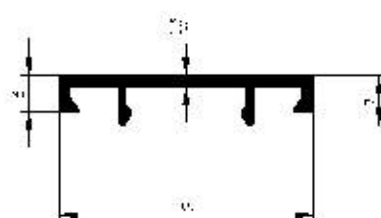

Profil No : 4005
Gramaj : 0.214 kg/m
Çevre : 112 mm

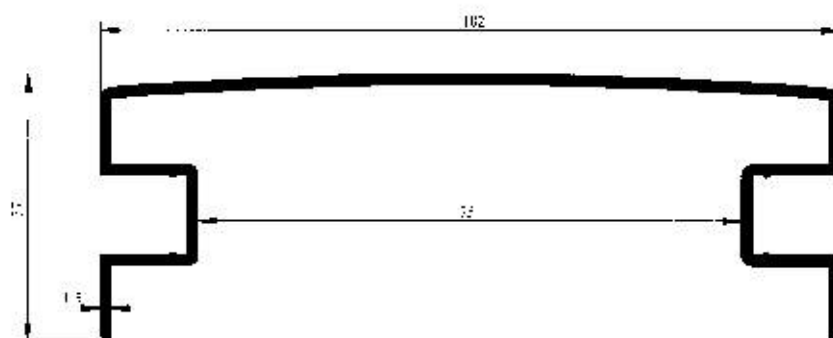

Profil No : 4035
Gramaj : 0.875 kg/m
Çevre : 433 mm

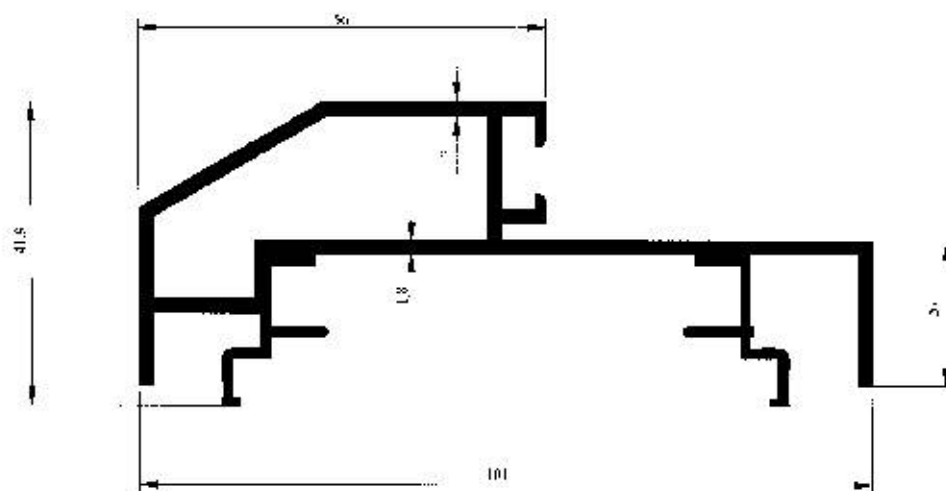

Profil No : 4096
Gramaj : 1.499 kg/m
Çevre : 473 mm



Alucomplast

Hlinikove profily na výtahy
Lift Profiles

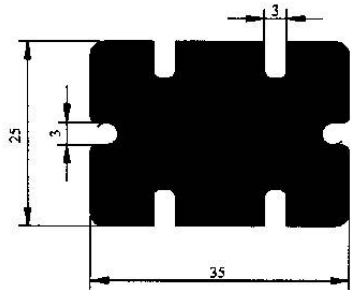

Profil No : 2252
Gramaj : 1.854 kg/m
Çevre : 225 mm

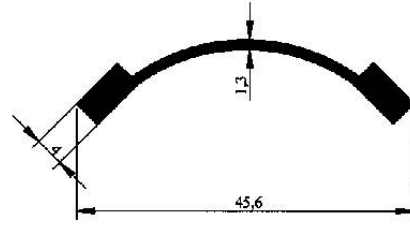

Profil No : 2789
Gramaj : 0.281 kg/m
Çevre : 108 mm

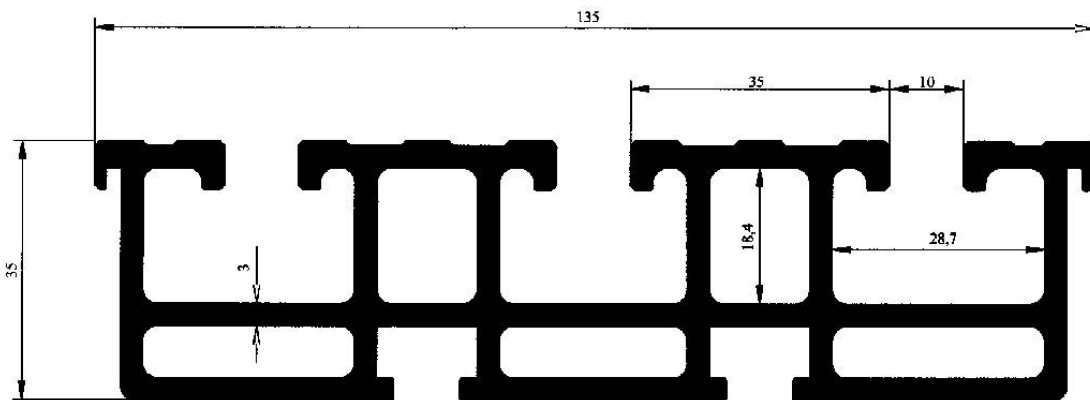

Profil No : 2260
Gramaj : 4.381 kg/m
Çevre : 462 mm

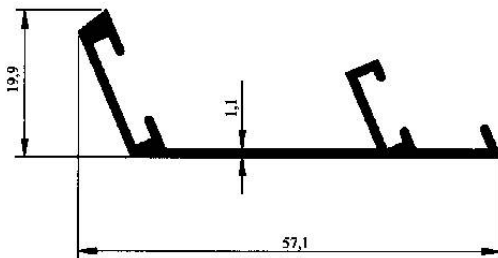

Profil No : 2793
Gramaj : 0.332 kg/m
Çevre : 201 mm

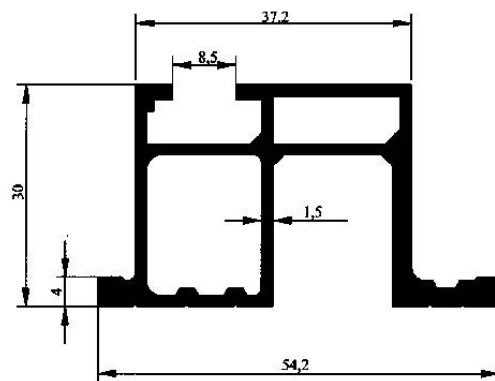

Profil No : 2796
Gramaj : 0.926 kg/m
Çevre : 241 mm

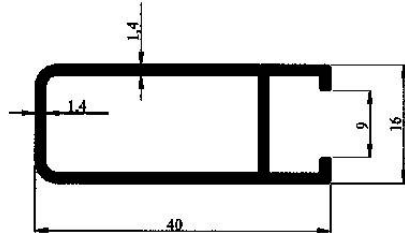

Profil No : 3222
Gramaj : 0.412 kg/m
Çevre : 134 mm

Hliníkové profily na výtahy
Lift Profiles

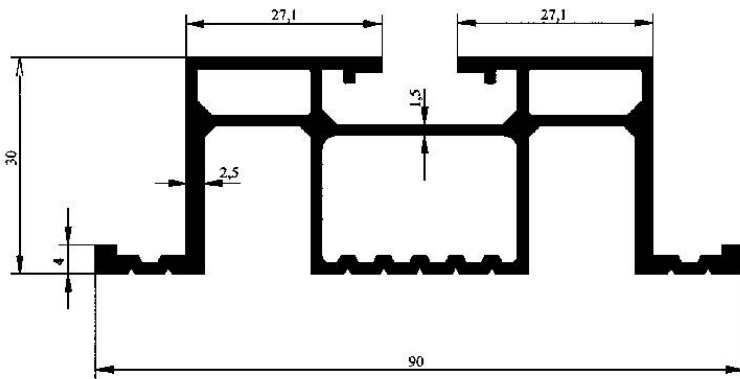

Profil No : 2803
Gramaj : 1.412 kg/m
Çevre : 397 mm

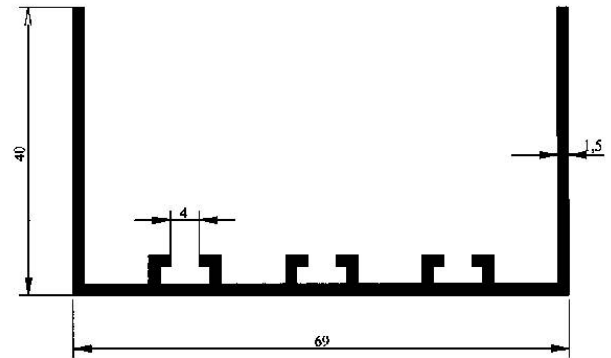

Profil No : 2844
Gramaj : 0.726 kg/m
Çevre : 361 mm

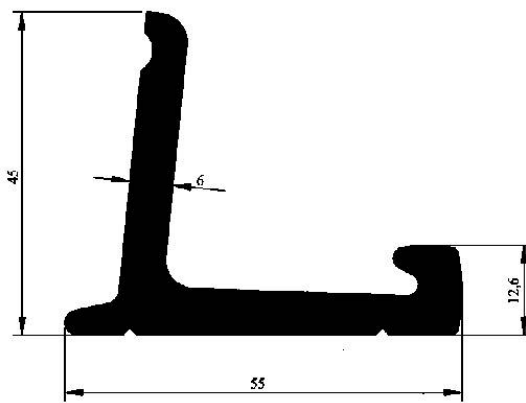

Profil No : 3131
Gramaj : 1.599 kg/m
Çevre : 210 mm

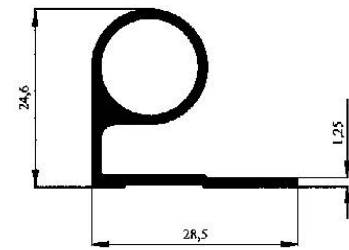

Profil No : 3209
Gramaj : 0.323kg/m
Çevre : 125 mm

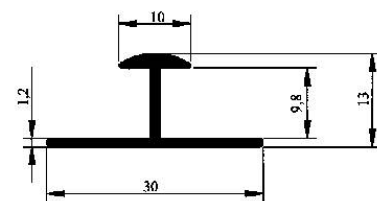

Profil No : 3621
Gramaj : 0.175 kg/m
Çevre : 99 mm

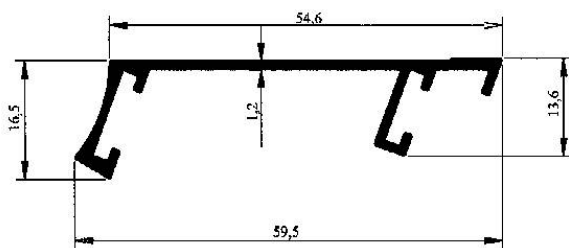

Profil No : 3216
Gramaj : 0.352 kg/m
Çevre : 199 mm



Hliníkové profily na výtahy
Lift Profiles

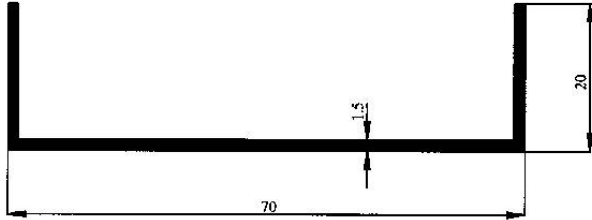

Profil No : 3226
Gramaj : 0.434 kg/m
Çevre : 216 mm

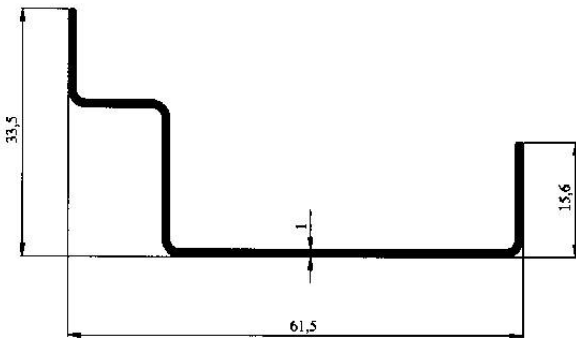

Profil No : 3229
Gramaj : 0.285 kg/m
Çevre : 212 mm

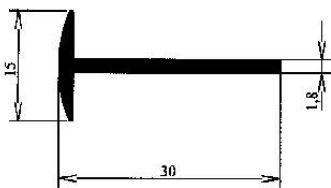

Profil No : 3231
Gramaj : 0.198 kg/m
Çevre : 87 mm

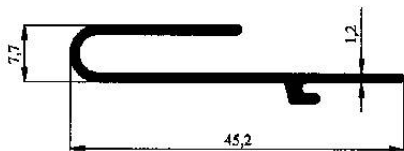

Profil No : 3233
Gramaj : 0.447 kg/m
Çevre : 152 mm

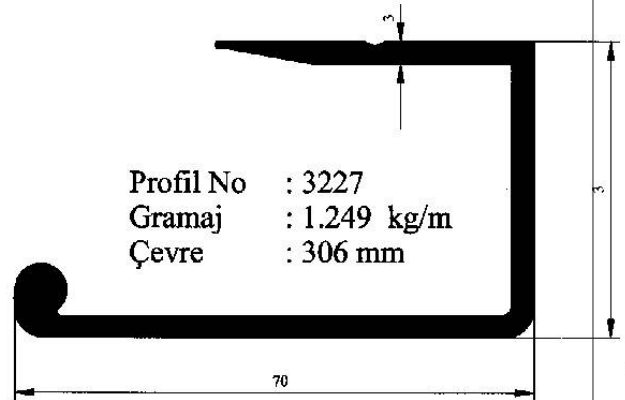

Profil No : 3227
Gramaj : 1.249 kg/m
Çevre : 306 mm

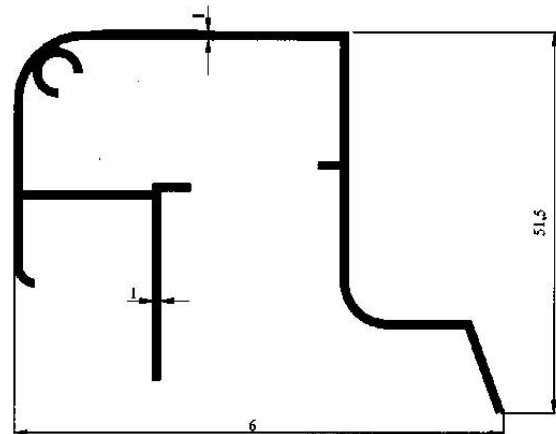

Profil No : 3230
Gramaj : 0.555 kg/m
Çevre : 404 mm

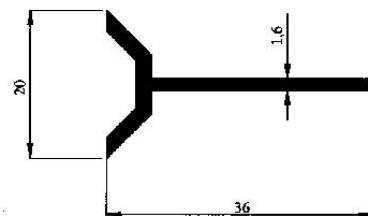

Profil No : 3232
Gramaj : 0.246 kg/m
Çevre : 108 mm

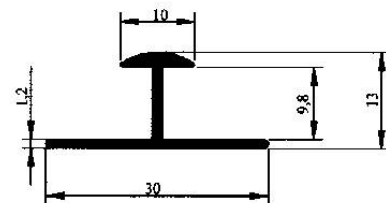

Profil No : 3621
Gramaj : 0.175 kg/m
Çevre : 99 mm

Hliníkové profily na výtahy
Lift Profiles

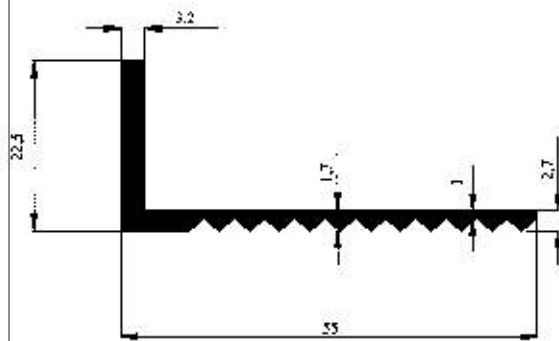

Profil No : 3234
Gramaj : 0.467 kg/m
Çevre : 167 mm

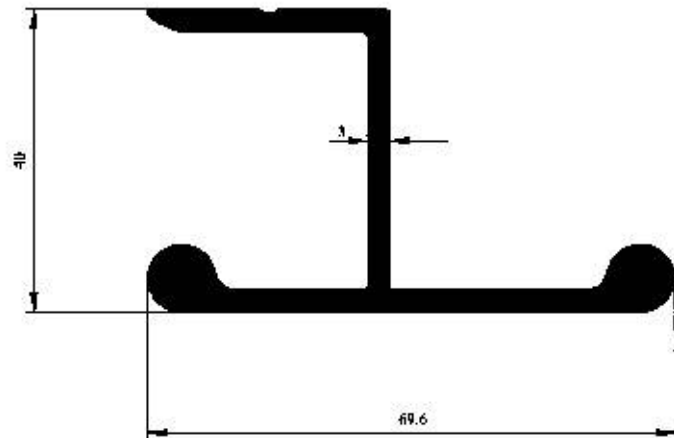

Profil No : 3235
Gramaj : 1.320 kg/m
Çevre : 285 mm

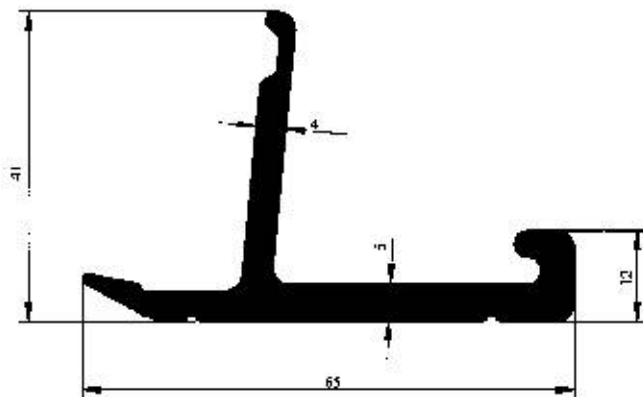

Profil No : 3263
Gramaj : 1.258 kg/m
Çevre : 227 mm

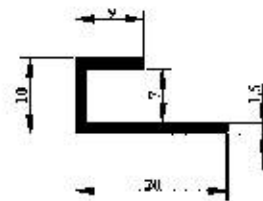

Profil No : 3559
Gramaj : 0.146 kg/m
Çevre : 74 mm

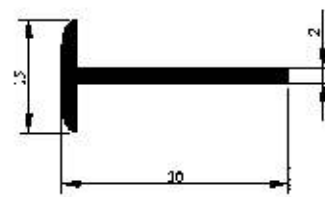

Profil No : 3844
Gramaj : 0.222 kg/m
Çevre : 88 mm

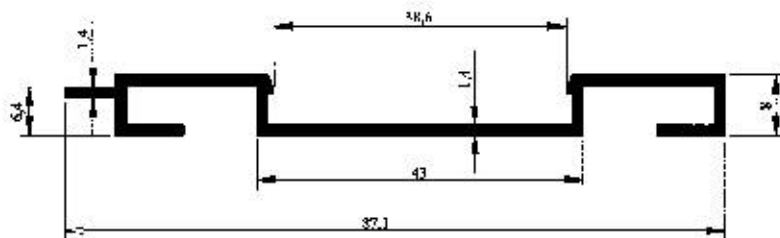

Profil No : 3846
Gramaj : 0.494 kg/m
Çevre : 262 mm

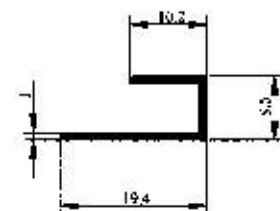

Profil No : 3845
Gramaj : 0.097 kg/m
Çevre : 73 mm

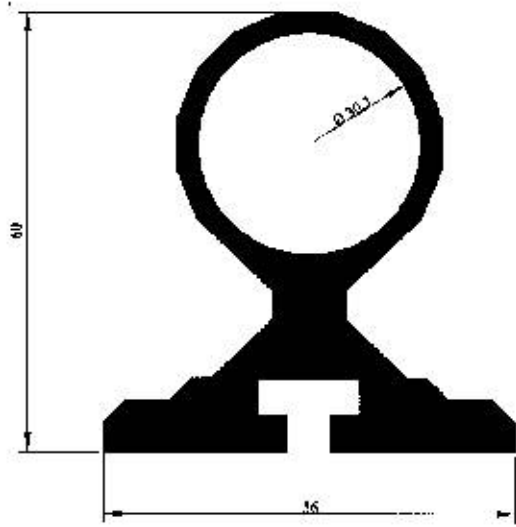

Profil No : 3854
Gramaj : 2.217 kg/m
Çevre : 229 mm

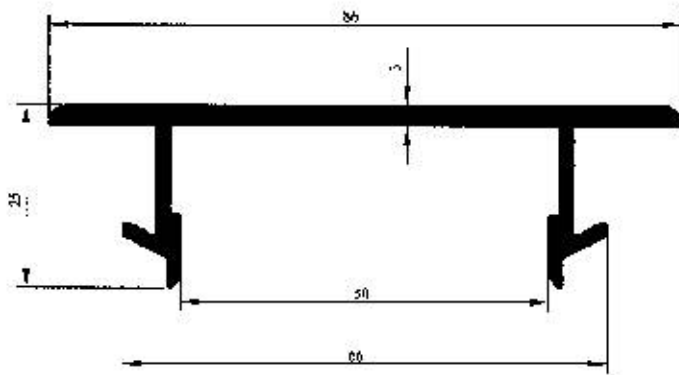

Profil No : 3835
Gramaj : 1.024 kg/m
Çevre : 248 mm

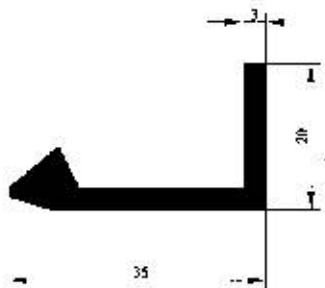

Profil No : 3860
Gramaj : 0.479 kg/m
Çevre : 113 mm

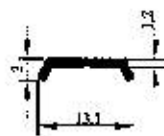

Profil No : 3880
Gramaj : 0.048 kg/m
Çevre : 32 mm

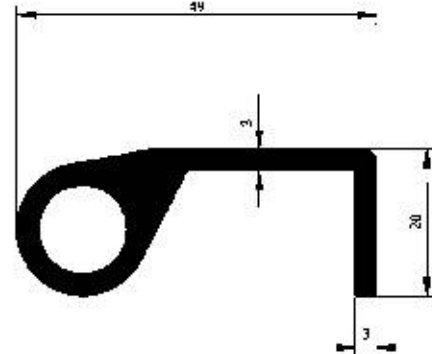

Profil No : 3856
Gramaj : 0.916 kg/m
Çevre : 154 mm

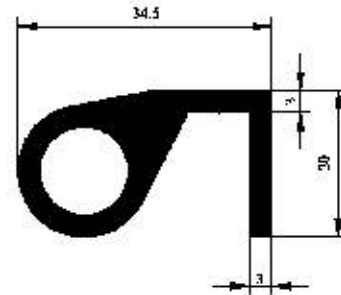

Profil No : 3857
Gramaj : 0.800 kg/m
Çevre : 125 mm

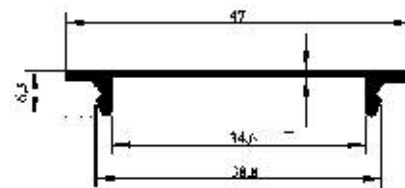

Profil No : 3881
Gramaj : 0.187 kg/m
Çevre : 115 mm

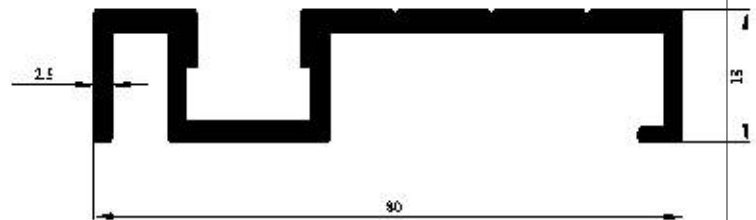

Profil No : 4730
Gramaj : 1.138 kg/m
Çevre : 296 mm

Hliníkové profily na výtahy
Lift Profiles

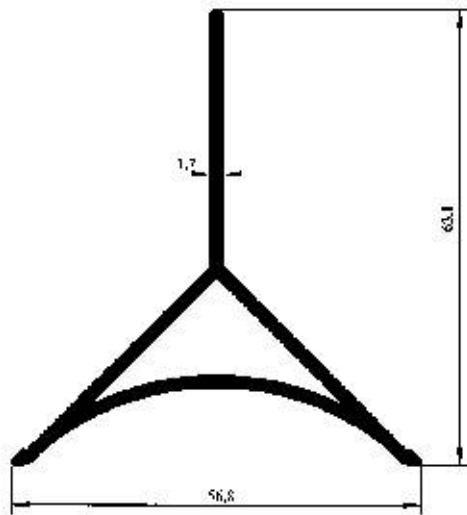

Profil No : 3879
Gramaj : 0.720 kg/m
Çevre : 214 mm

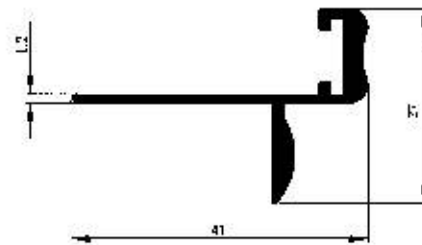

Profil No : 4039
Gramaj : 0.330 kg/m
Çevre : 146 mm

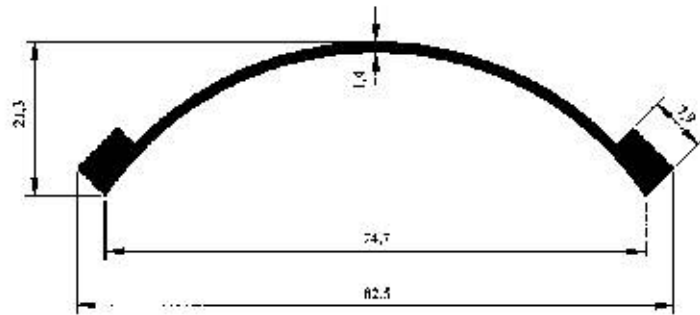

Profil No : 3896
Gramaj : 0.491 kg/m
Çevre : 196 mm

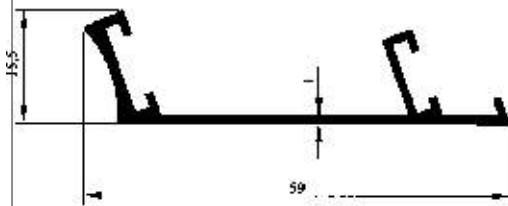

Profil No : 3864
Gramaj : 0.309 kg/m
Çevre : 195 mm

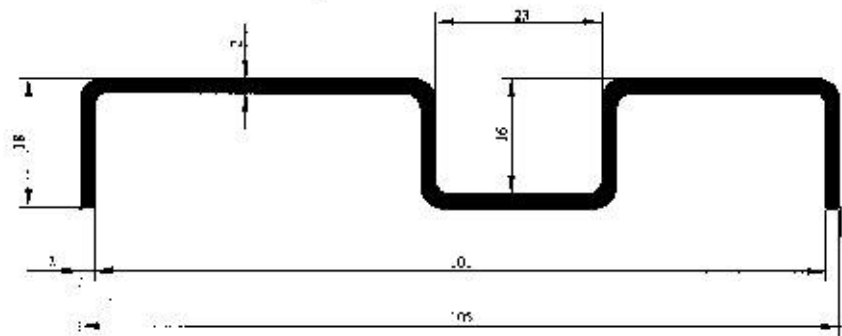

Profil No : 3861
Gramaj : 0.899 kg/m
Çevre : 329 mm

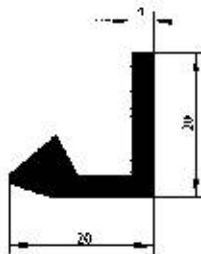

Profil No : 3859
Gramaj : 0.357 kg/m
Çevre : 83 mm

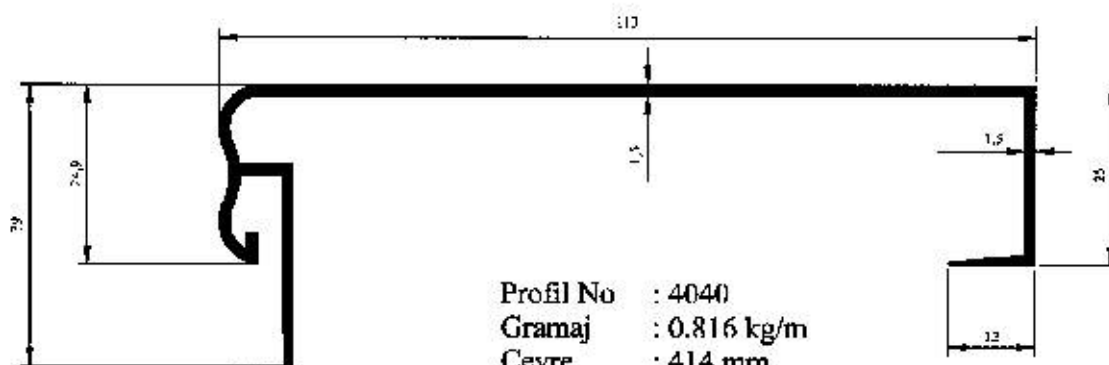

Profil No : 4040
Gramaj : 0.816 kg/m
Çevre : 414 mm





Alucomplast

Hliníkových Karoserií

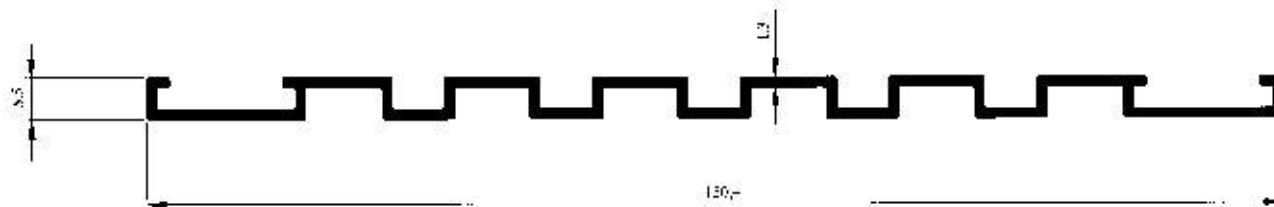

Profil No : 1954
 Gramaj : 0.761 kg/m
 Çevre : 426 mm

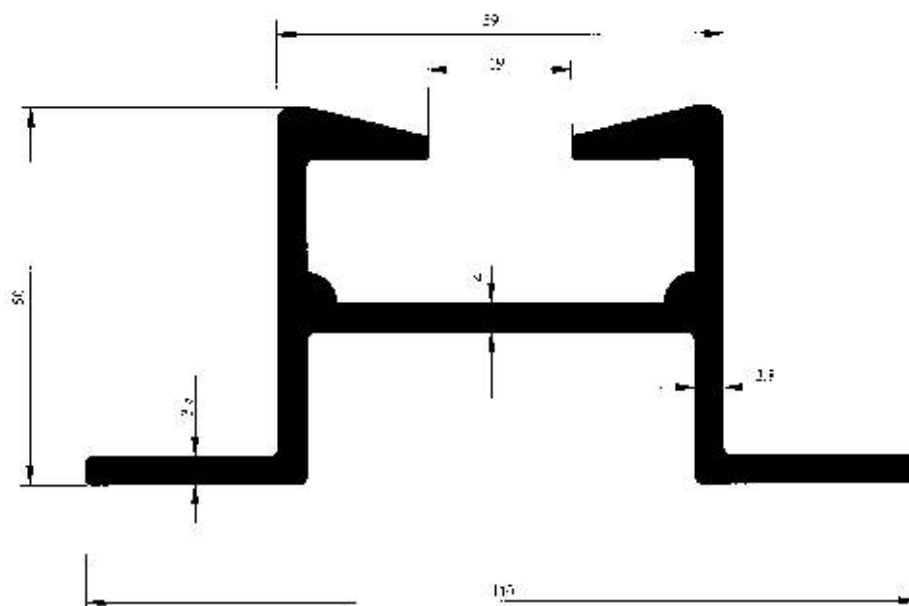

Profil No : 1955
 Gramaj : 2.614 kg/m
 Çevre : 462 mm

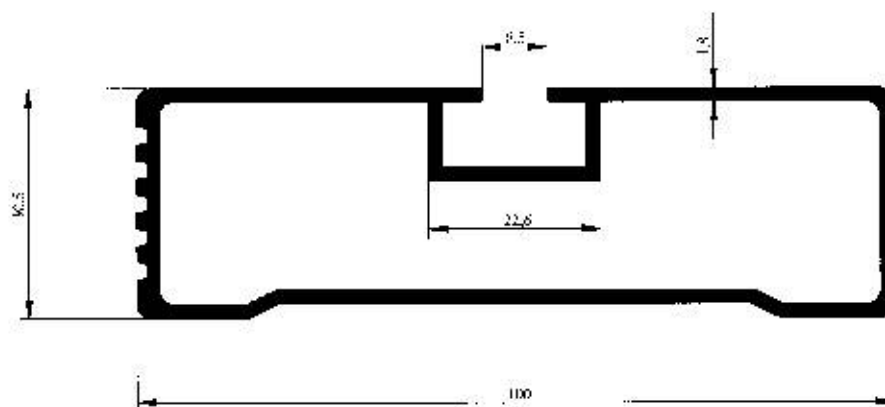

Profil No : 1956
 Gramaj : 1.441 kg/m
 Çevre : 312 mm

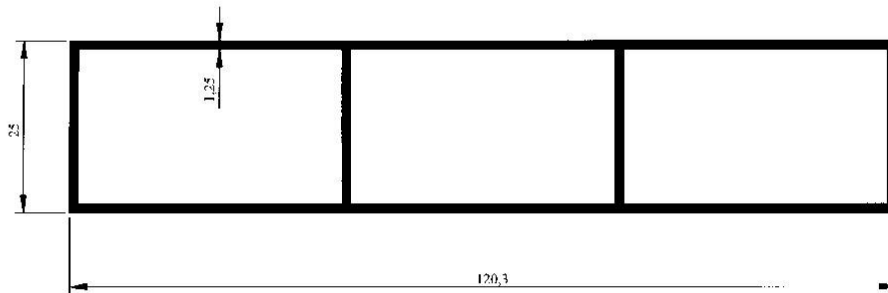

Profil No : 1957
Gramaj : 1.120 kg/m
Çevre : 291 mm

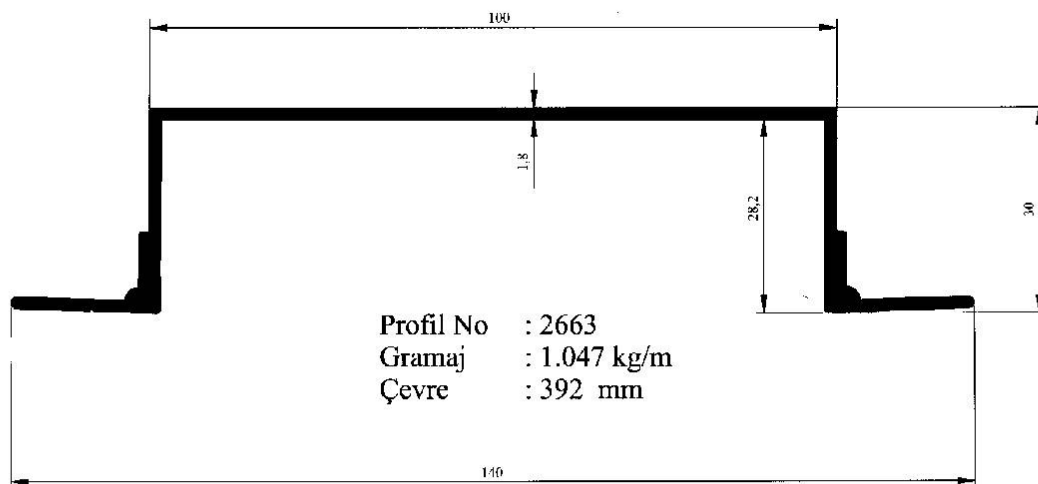

Profil No : 2663
Gramaj : 1.047 kg/m
Çevre : 392 mm

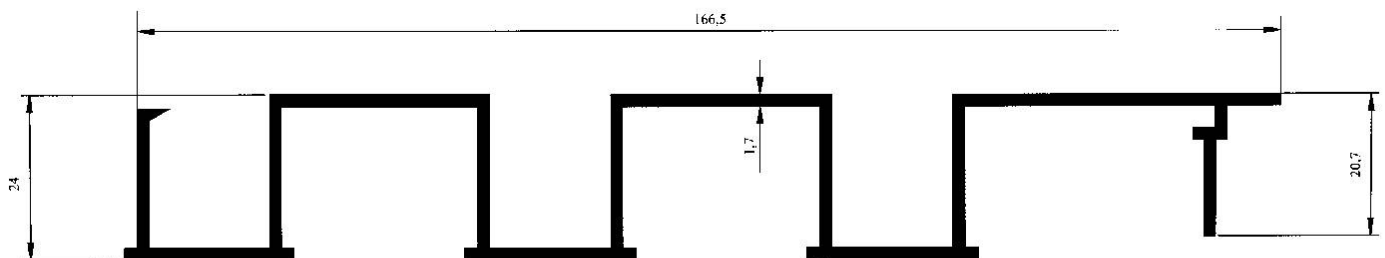

Profil No : 2712
Gramaj : 1.536 kg/m
Çevre : 674 mm

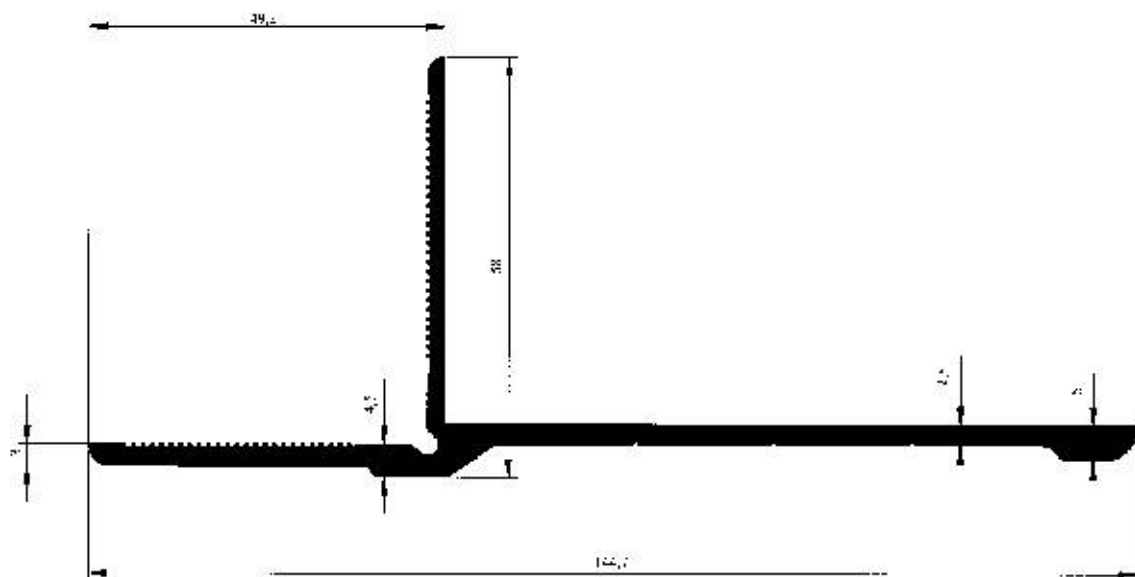

Profil No : 2711
 Gramaj : 1.545 kg/m
 Çevre : 447 mm

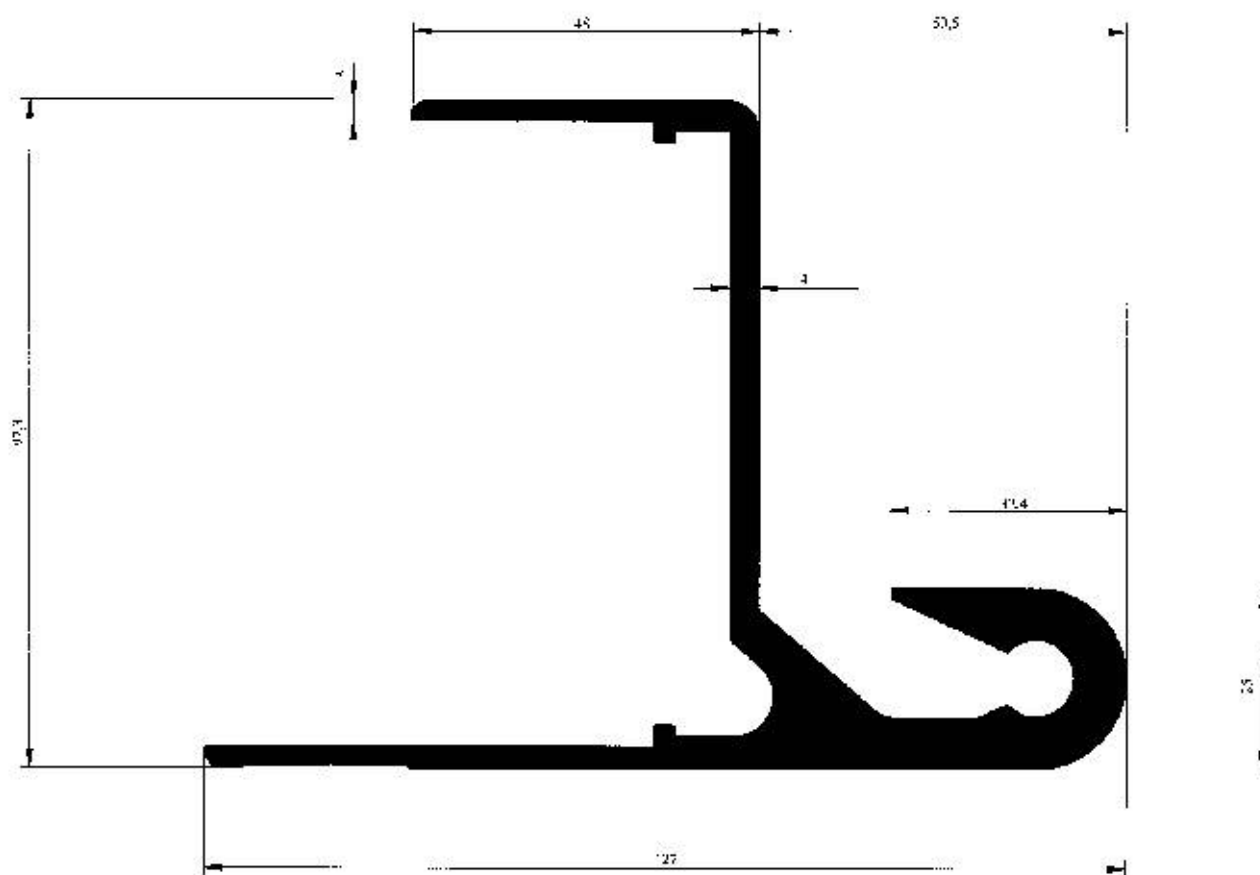

Profil No : 2710
 Gramaj : 3.802 kg/m
 Çevre : 592 mm

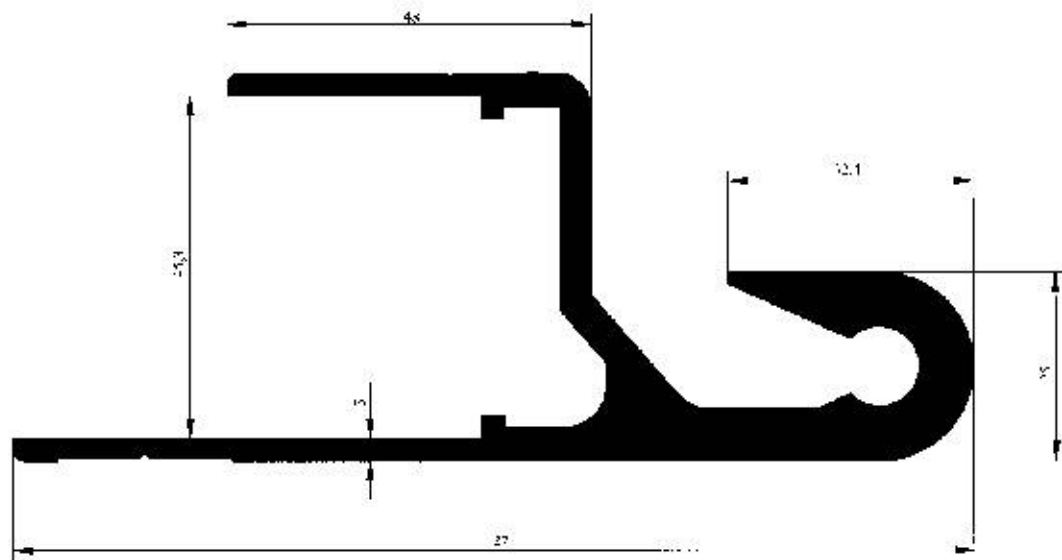

Profil No : 2713
Gramaj : 3.257 kg/m
Çevre : 514 mm

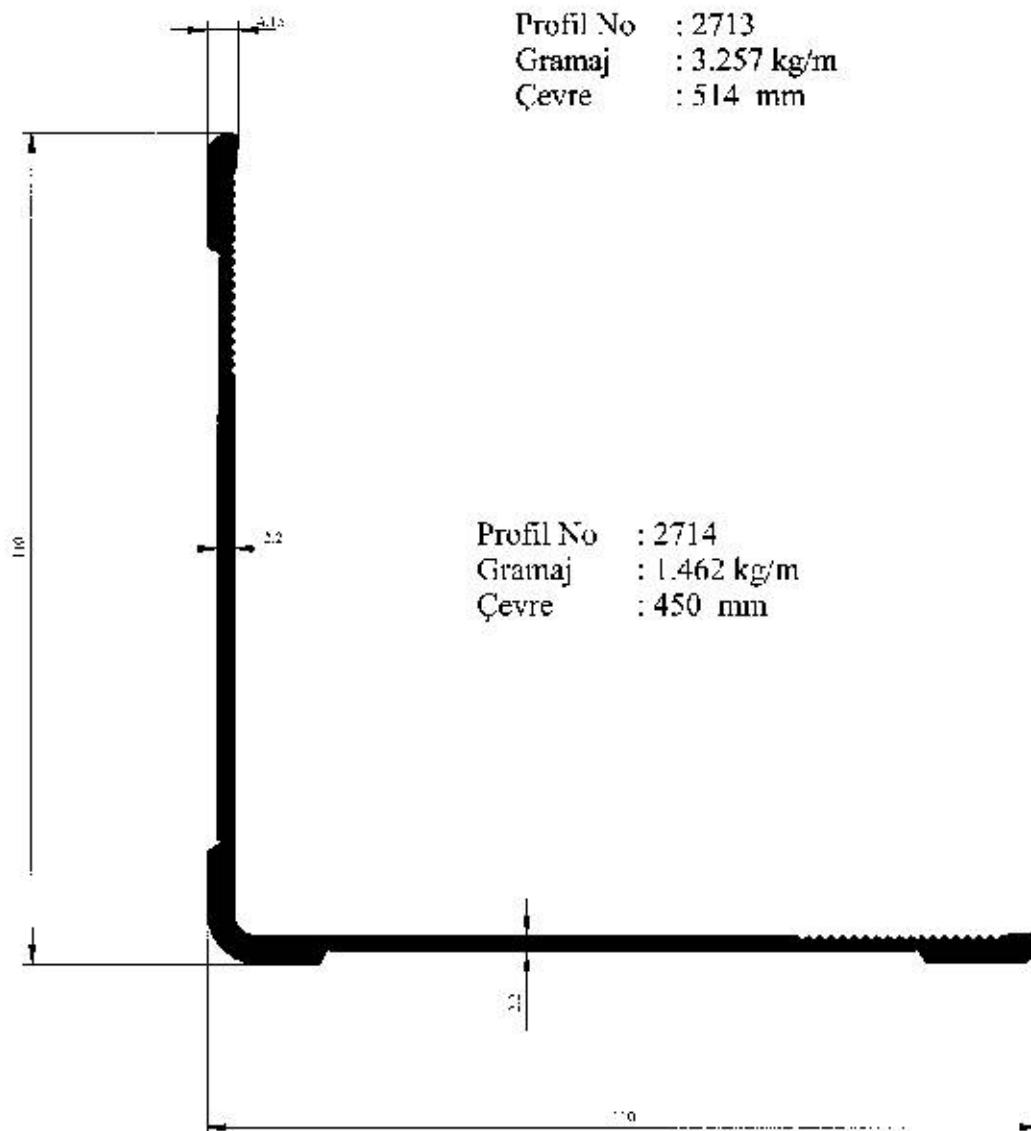

Profil No : 2714
Gramaj : 1.462 kg/m
Çevre : 450 mm

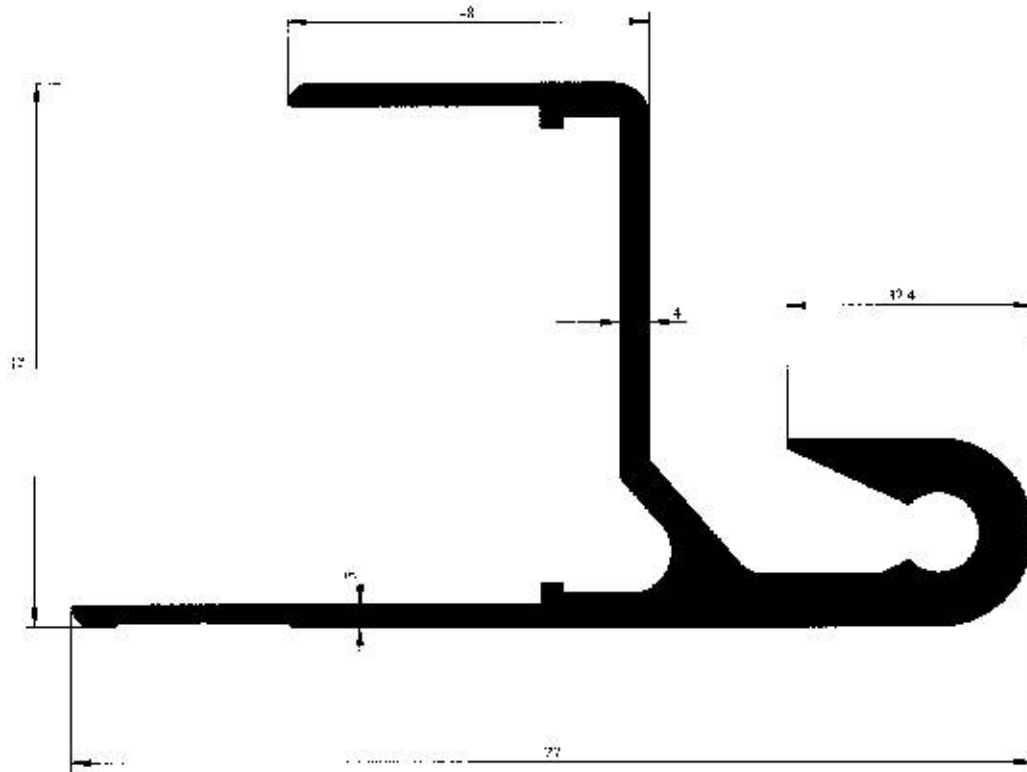

Profil No : 2732
 Gramaj : 3.455 kg/m
 Çevre : 554 mm

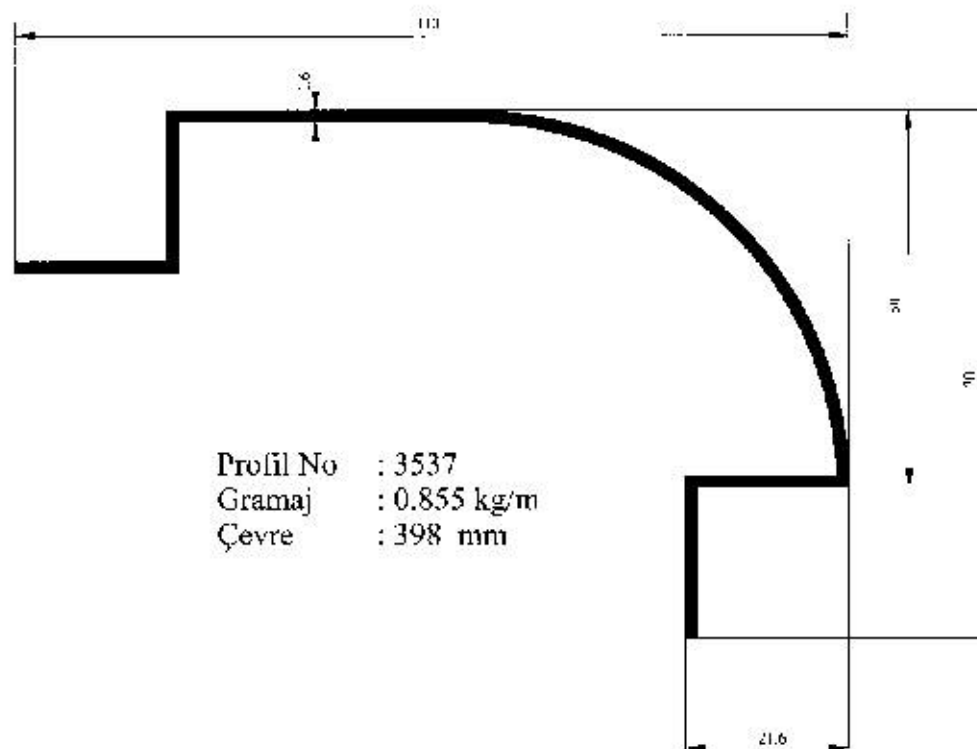

Profil No : 3537
 Gramaj : 0.855 kg/m
 Çevre : 398 mm

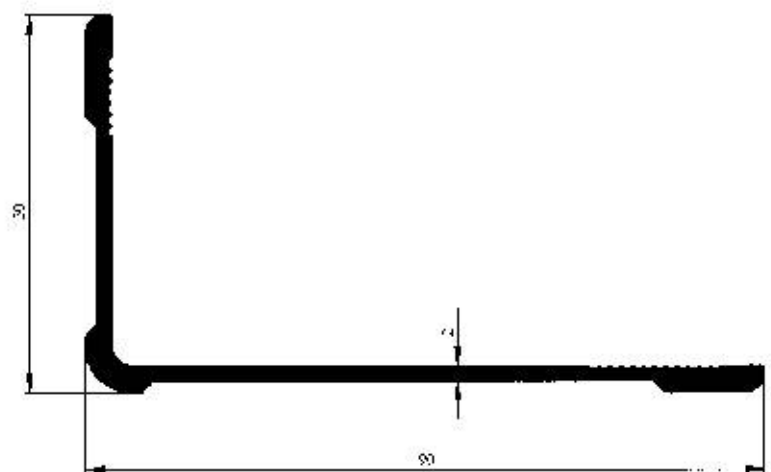
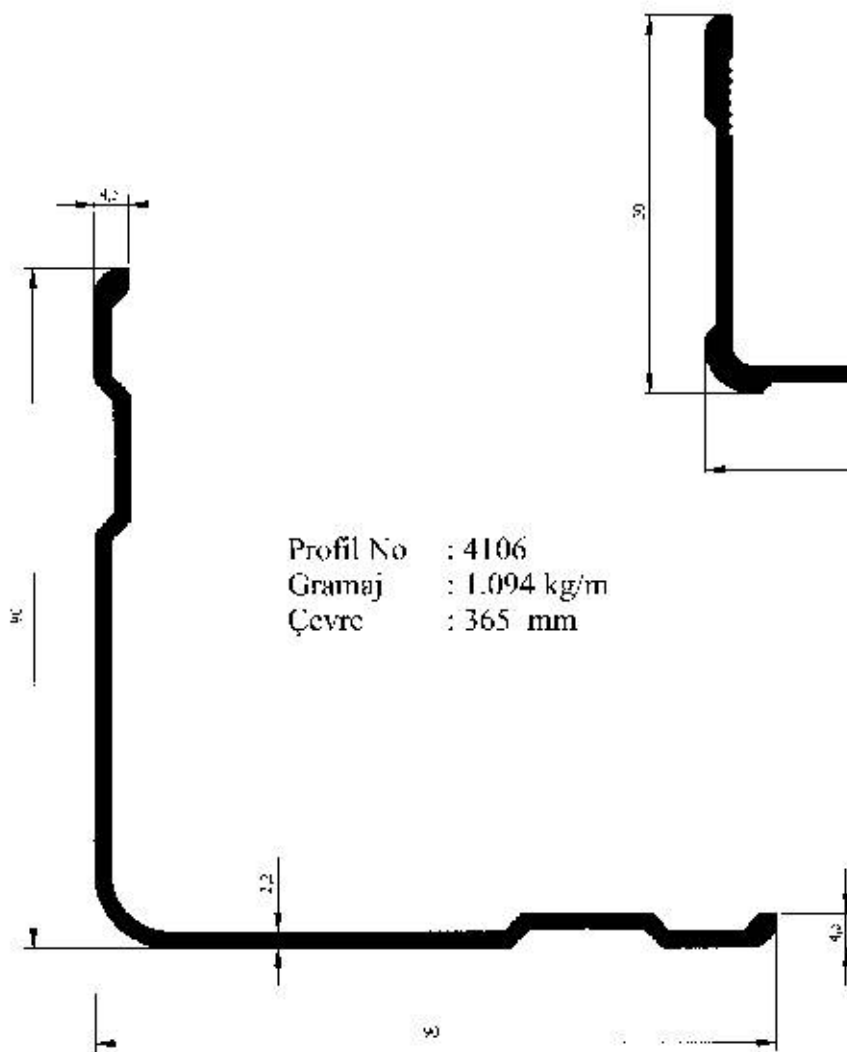
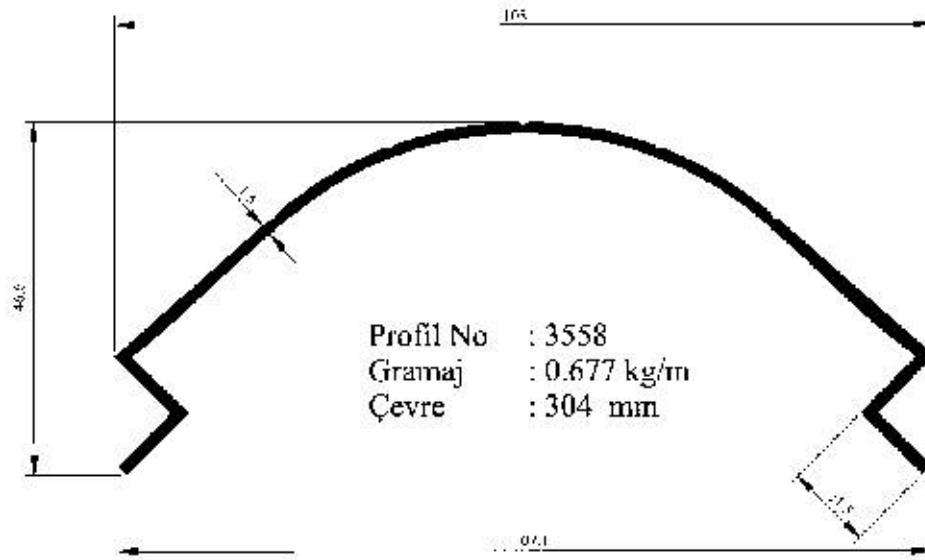

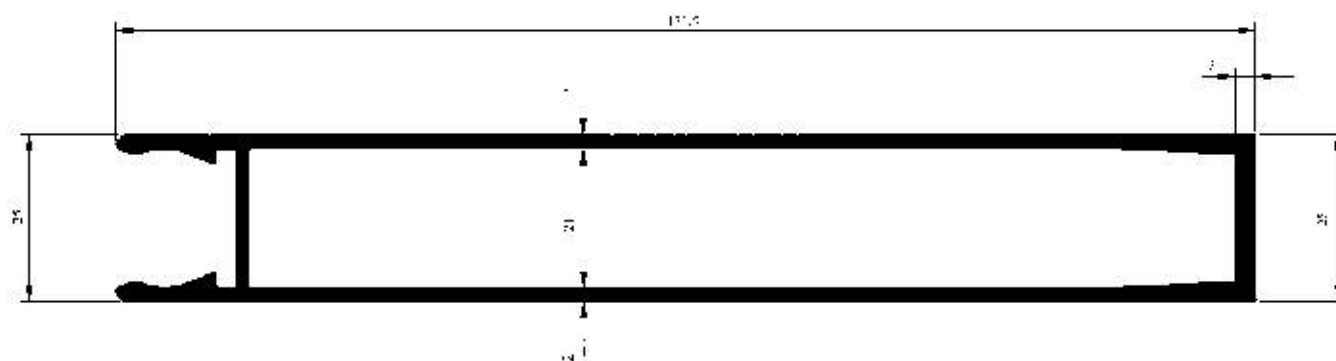

Profil No : 4155
 Gramaj : 2.274 kg/m
 Çevre : 432 mm

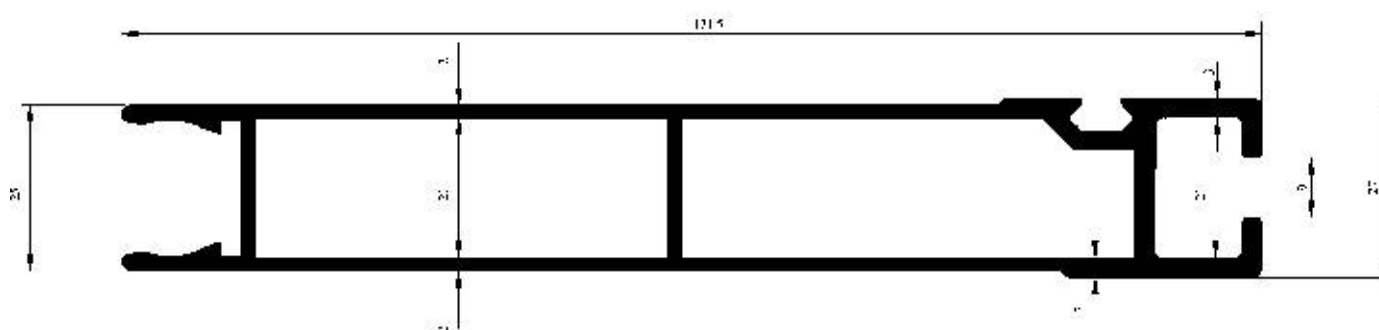

Profil No : 4156
 Gramaj : 2.656 kg/m
 Çevre : 498 mm

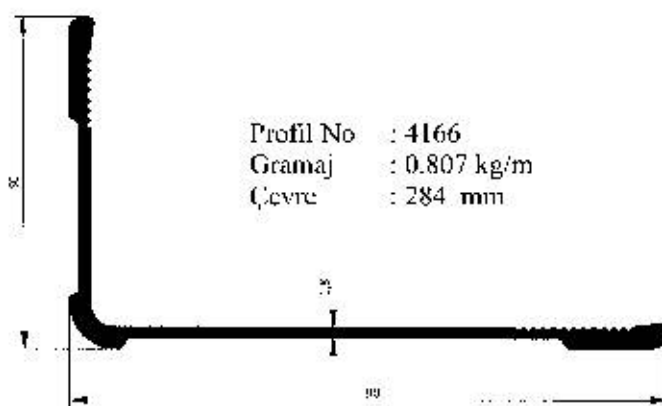

Profil No : 4166
 Gramaj : 0.807 kg/m
 Çevre : 284 mm

Hliníkových Karoserií

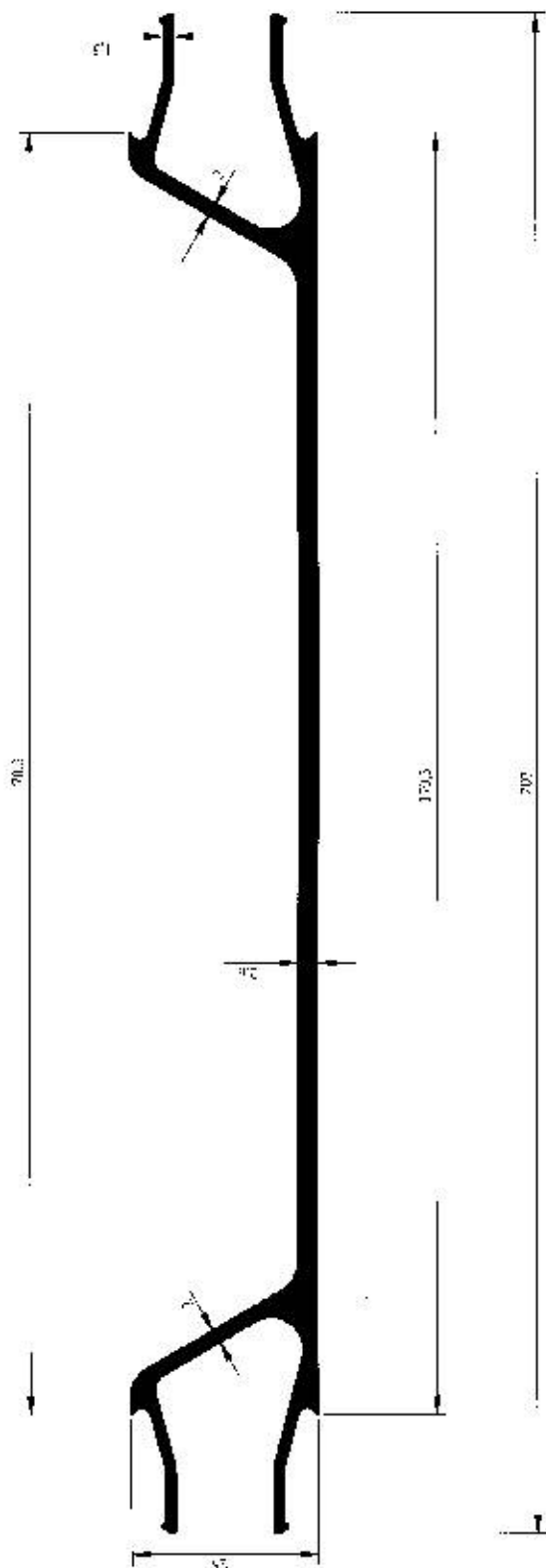

Profil No : 4153
Gramaj : 1.865 kg/m
Çevre : 587 mm

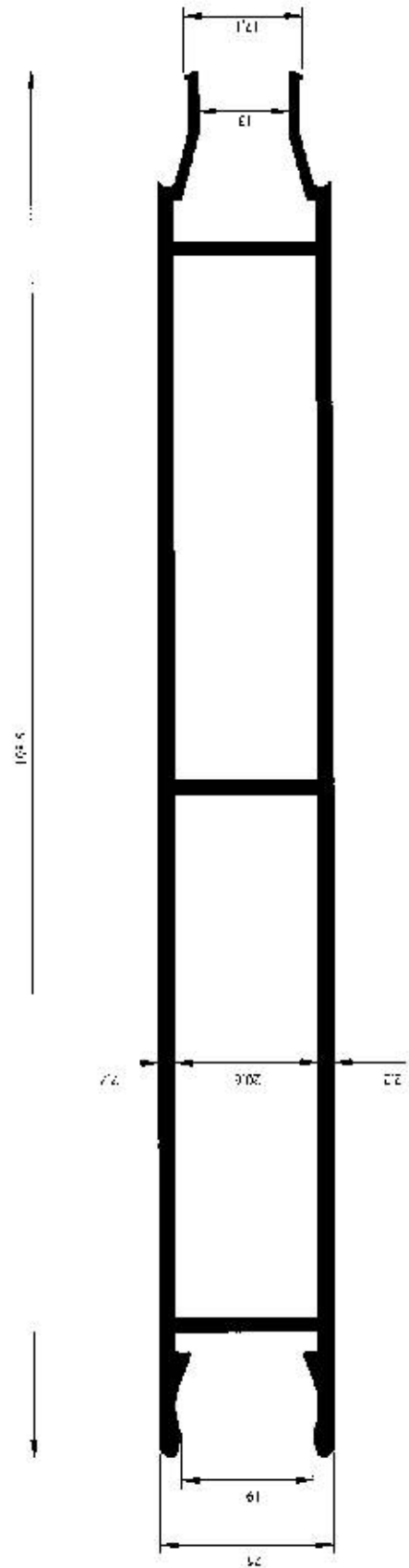

Profil No : 4154
Gramaj : 2.710 kg/m
Çevre : 543 mm

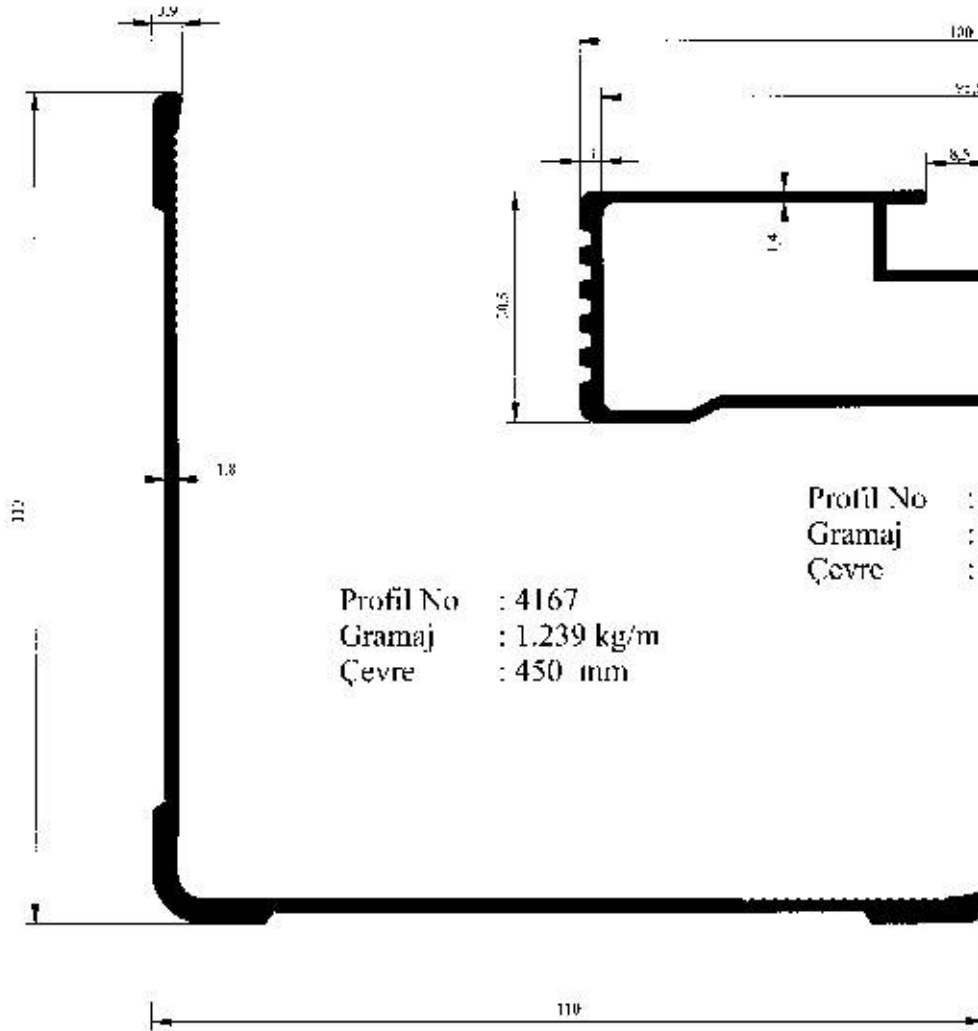

Profil No : 4167
 Gramaj : 1.239 kg/m
 Çevre : 450 mm

Profil No : 4288
 Gramaj : 1.181 kg/m
 Çevre : 311 mm

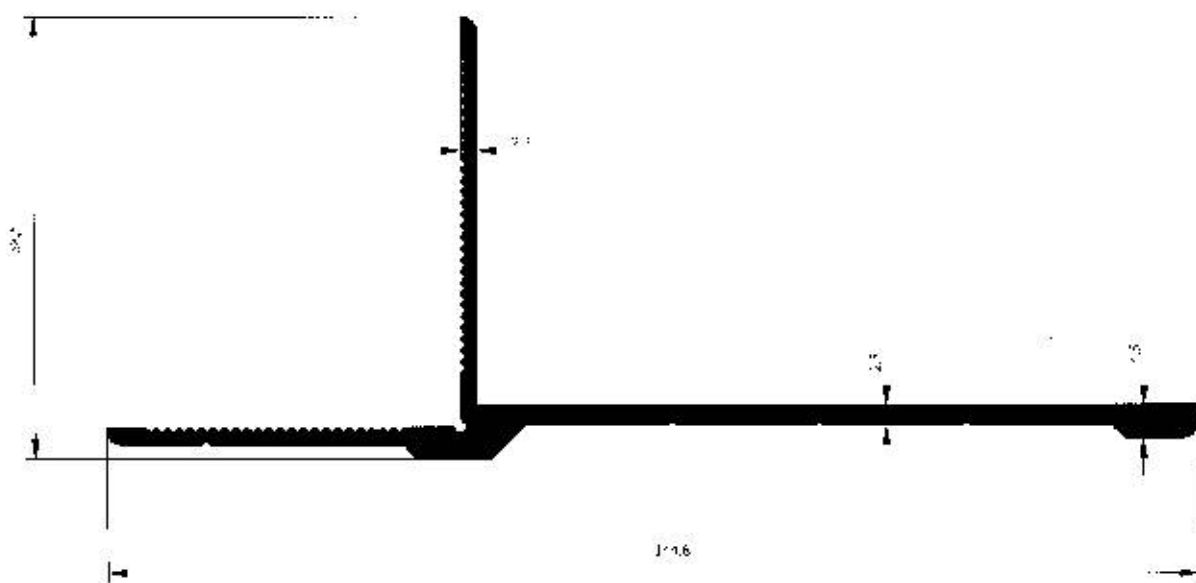

Profil No : 4168
 Gramaj : 1.444 kg/m
 Çevre : 422 mm



Alucomplast

Stavebních Profilů

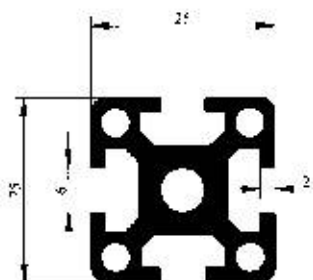

Profil No : 2818
 Gramaj : 0.818 kg/m
 Çevre : 253 mm

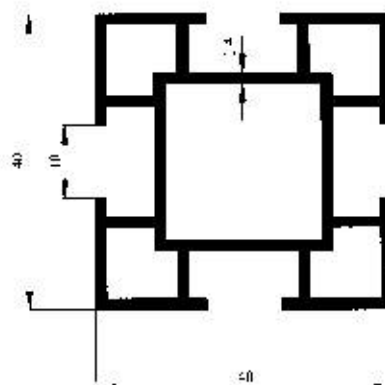

Profil No : 3073
 Gramaj : 0.977 kg/m
 Çevre : 264 mm

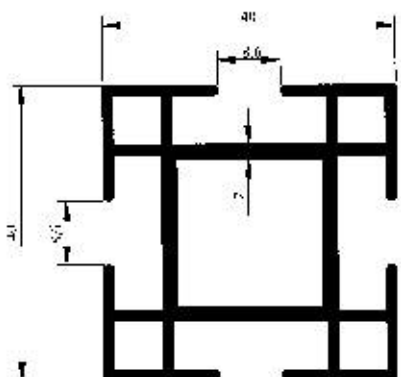

Profil No : 3324
 Gramaj : 1.128 kg/m
 Çevre : 320 mm

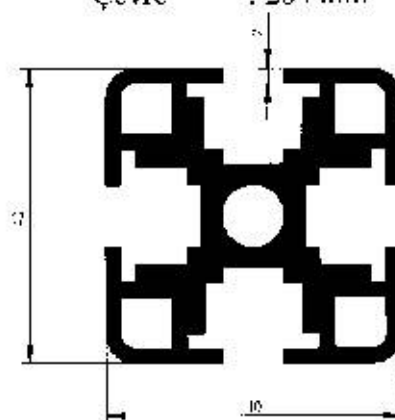

Profil No : 3577
 Gramaj : 1.871 kg/m
 Çevre : 335 mm

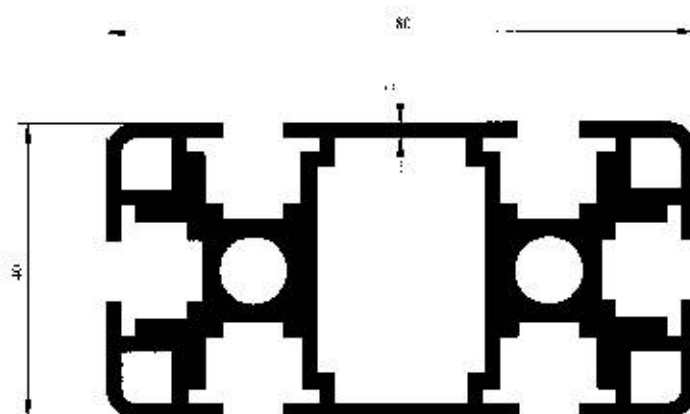

Profil No : 3578
 Gramaj : 3.057 kg/m
 Çevre : 508 mm

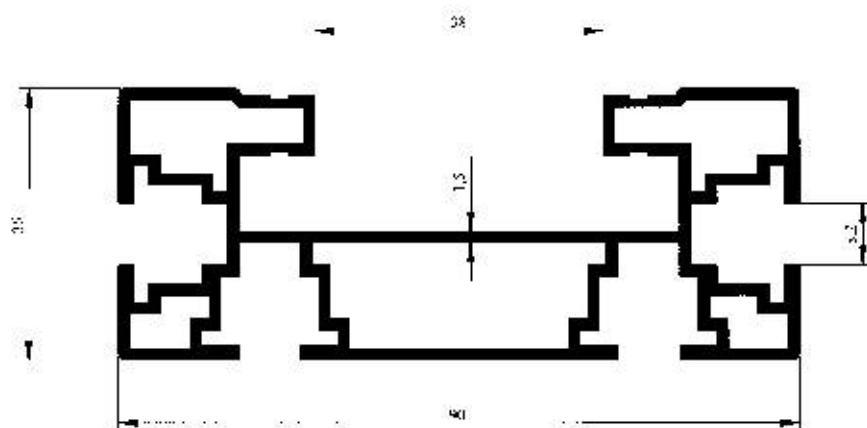

Profil No : 3633
Gramaj : 1.790 kg/m
Çevre : 529 mm

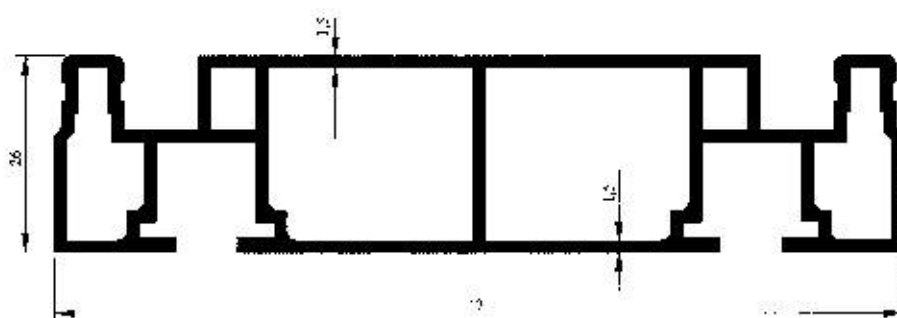

Profil No : 3634
Gramaj : 1.718 kg/m
Çevre : 415 mm





Alucomplast

Hliníková okna a dveře
Windows And Doors Profiles

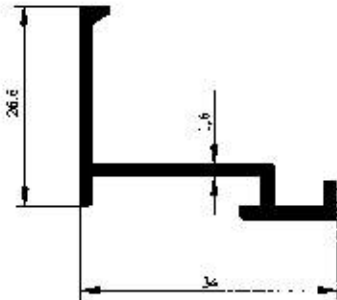

Profil No : 2300
Gramaj : 0.318 kg/m
Çevre : 148 mm

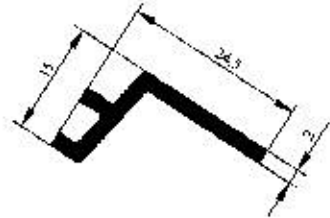

Profil No : 2320
Gramaj : 0.213 kg/m
Çevre : 81 mm

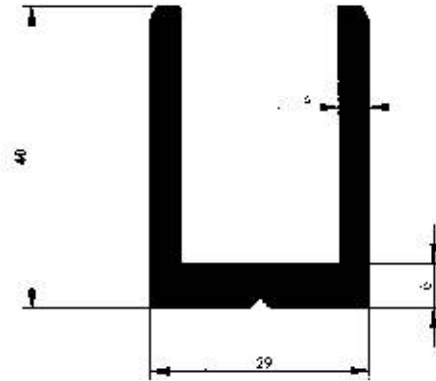

Profil No : 2319
Gramaj : 1.198 kg/m
Çevre : 206 mm

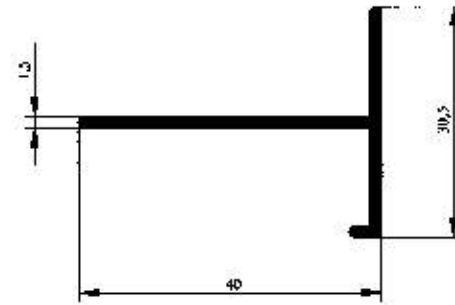

Profil No : 2321
Gramaj : 0.290 kg/m
Çevre : 145 mm

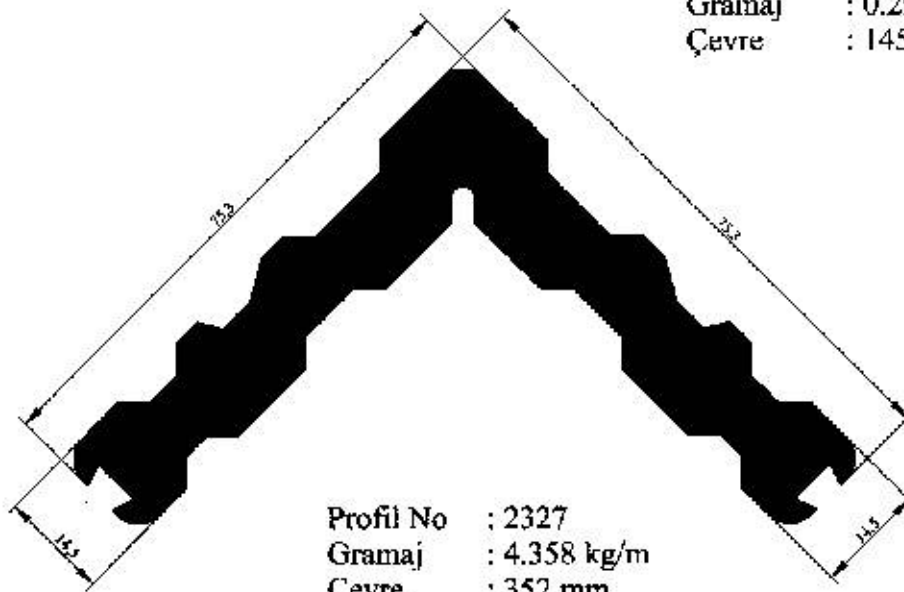

Profil No : 2327
Gramaj : 4.358 kg/m
Çevre : 352 mm

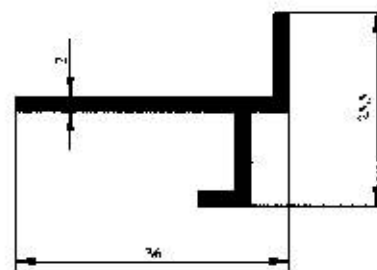
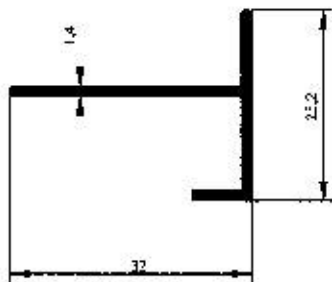
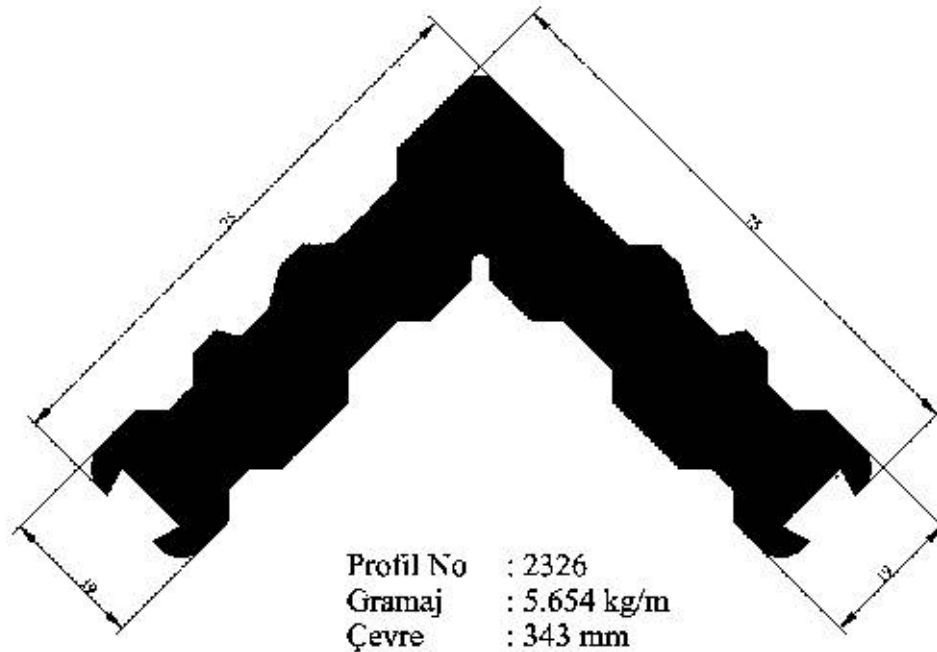
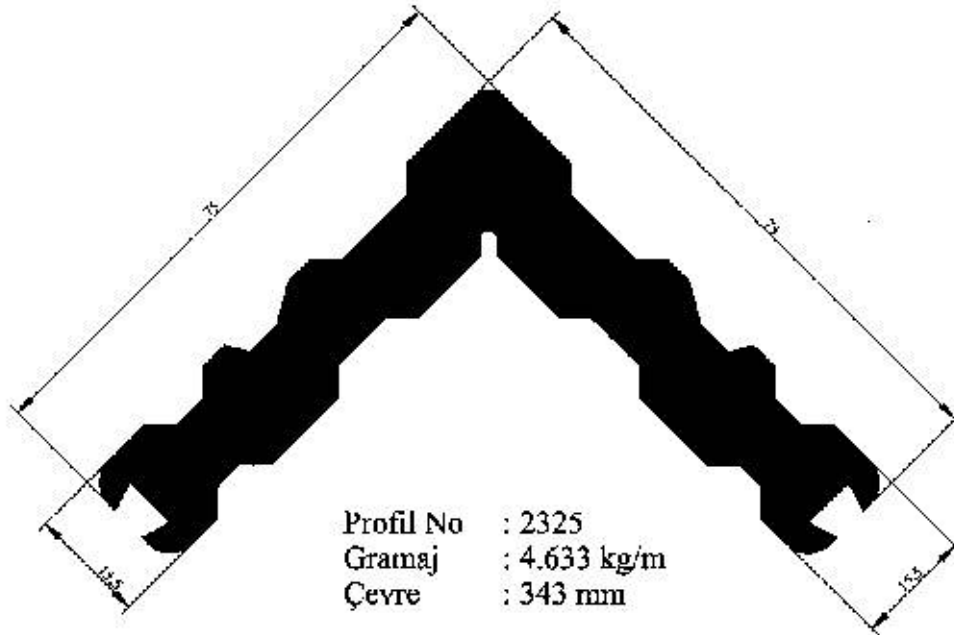



Hliníková okna a dveře
Windows And Doors Profiles

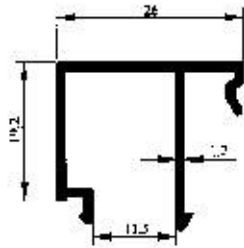

Profil No : 2331
 Gramaj : 0.268 kg/m
 Çevre : 164 mm

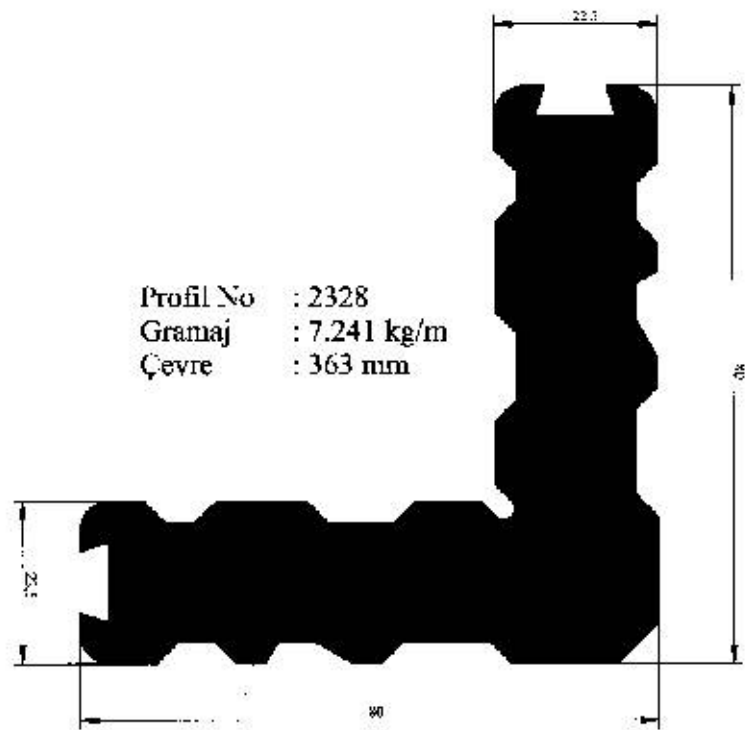

Profil No : 2328
 Gramaj : 7.241 kg/m
 Çevre : 363 mm

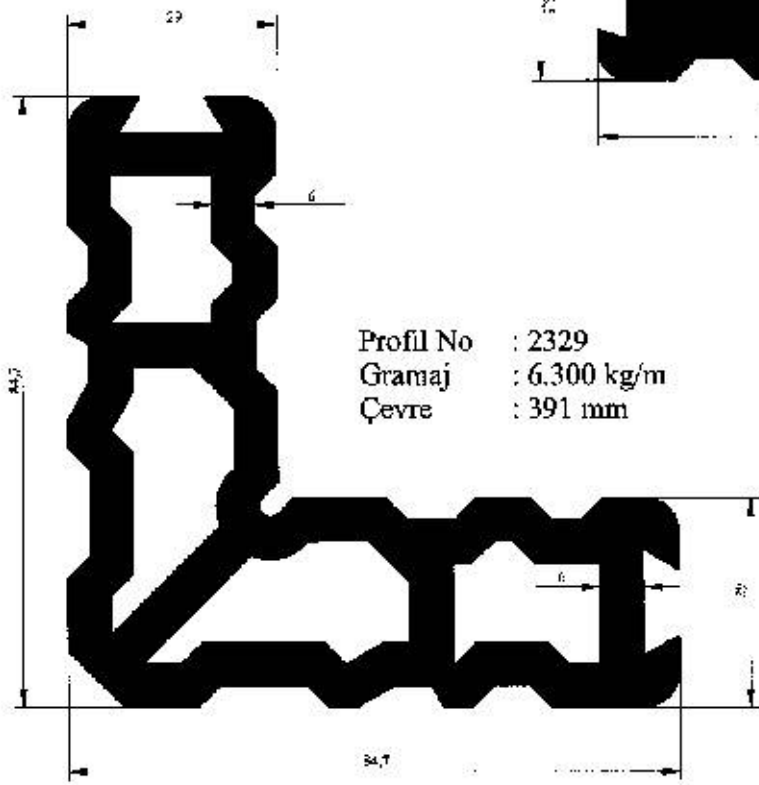

Profil No : 2329
 Gramaj : 6.300 kg/m
 Çevre : 391 mm

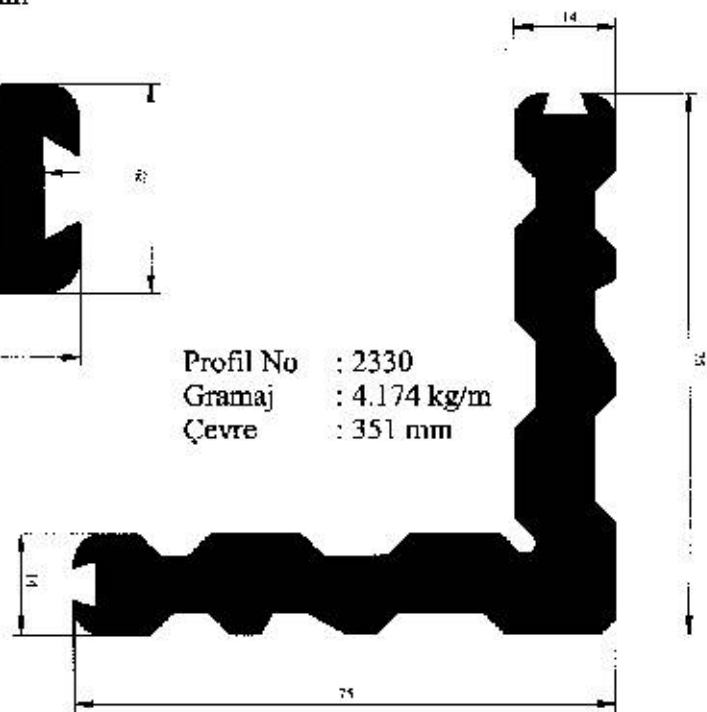

Profil No : 2330
 Gramaj : 4.174 kg/m
 Çevre : 351 mm

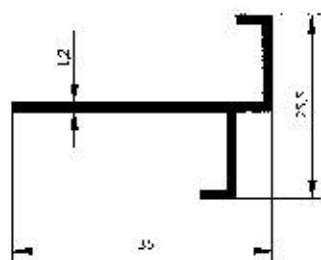

Profil No : 2334
 Gramaj : 0.221 kg/m
 Çevre : 138 mm

Hliníková okna a dveře
Windows And Doors Profiles

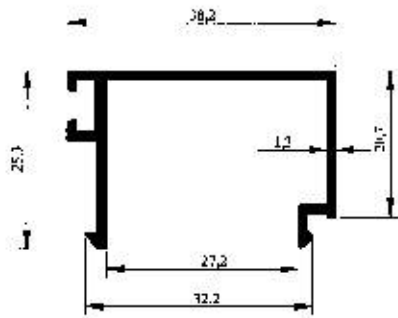

Profil No : 2400
Gramaj : 0.363 kg/m
Çevre : 198 mm

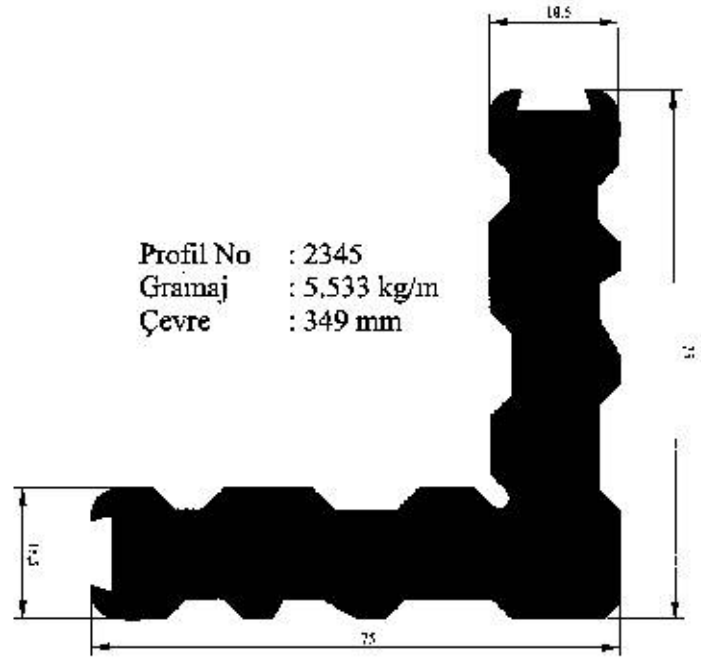

Profil No : 2345
Gramaj : 5.533 kg/m
Çevre : 349 mm

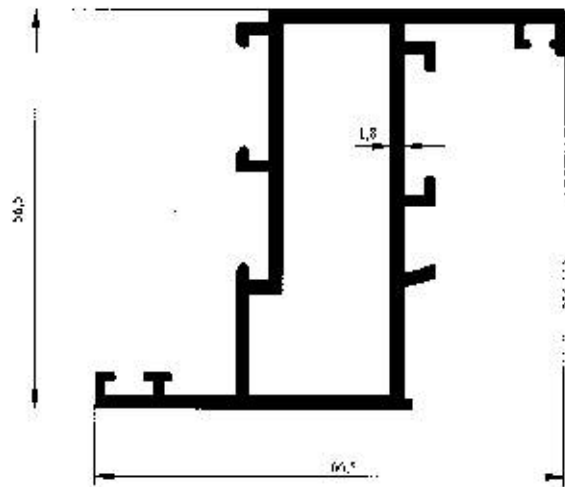

Profil No : 2403
Gramaj : 1.236 kg/m
Çevre : 517 mm

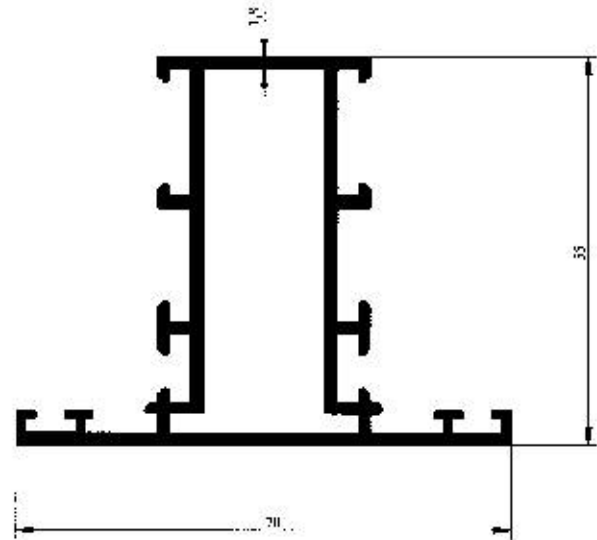

Profil No : 2404
Gramaj : 1.285 kg/m
Çevre : 390 mm

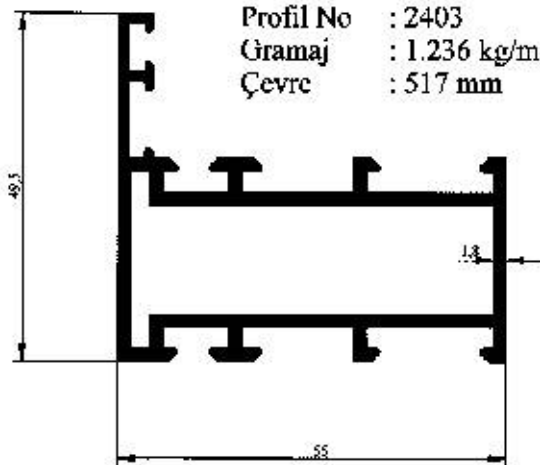

Profil No : 2405
Gramaj : 1.192 kg/m
Çevre : 327 mm

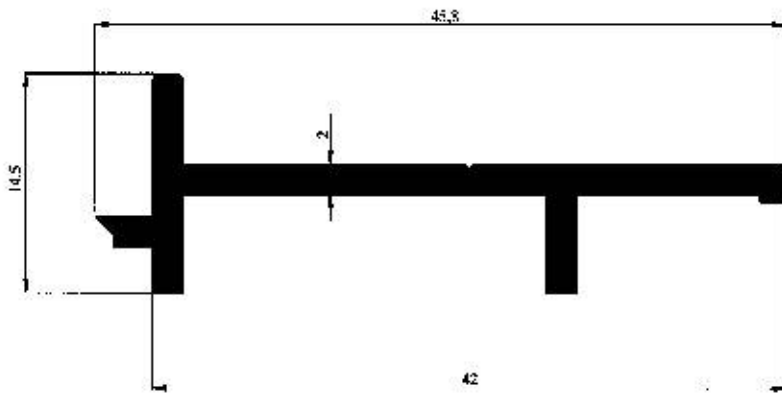

Profil No : 2411
Gramaj : 0.349 kg/m
Çevre : 133 mm

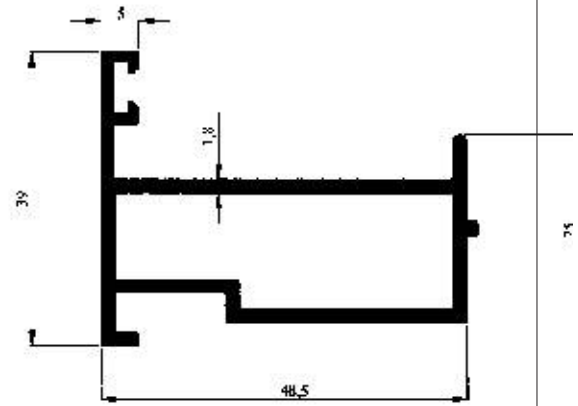

Profil No : 2438
Gramaj : 0.816 kg/m
Çevre : 221 mm

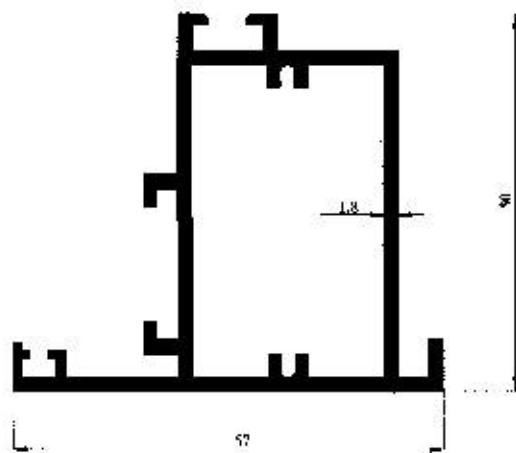

Profil No : 2439
Gramaj : 1.069 kg/m
Çevre : 291 mm

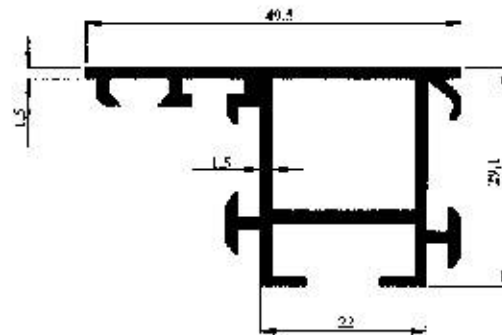

Profil No : 2462
Gramaj : 0.718 kg/m
Çevre : 279 mm

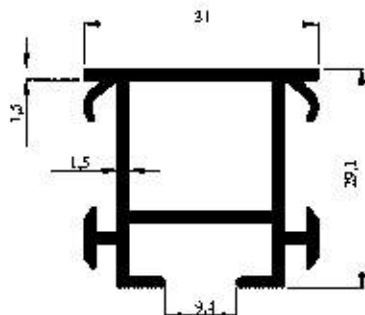

Profil No : 2463
Gramaj : 0.588 kg/m
Çevre : 223 mm

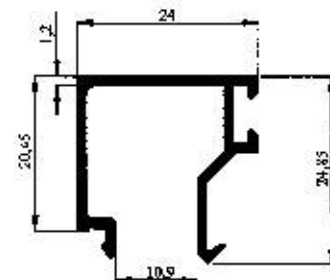

Profil No : 2496
Gramaj : 0.280 kg/m
Çevre : 168 mm

Hliníková okna a dveře
Windows And Doors Profiles

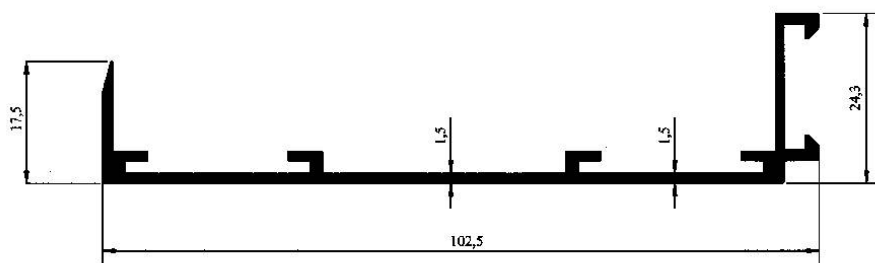

Profil No : 2493
Gramaj : 0.684 kg/m
Çevre : 339 mm

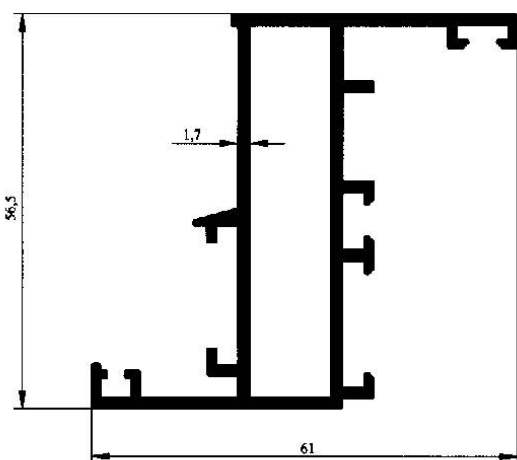

Profil No : 2494
Gramaj : 1.086 kg/m
Çevre : 353 mm

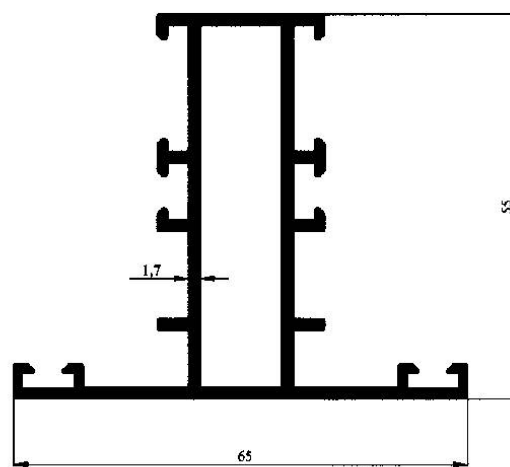

Profil No : 2495
Gramaj : 1.125 kg/m
Çevre : 372 mm

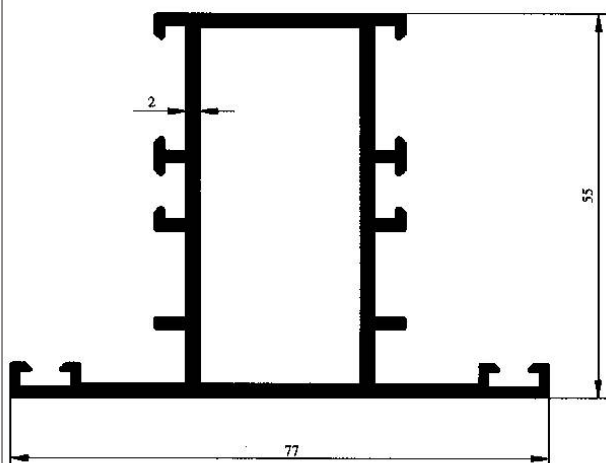

Profil No : 2502
Gramaj : 1.380 kg/m
Çevre : 395 mm

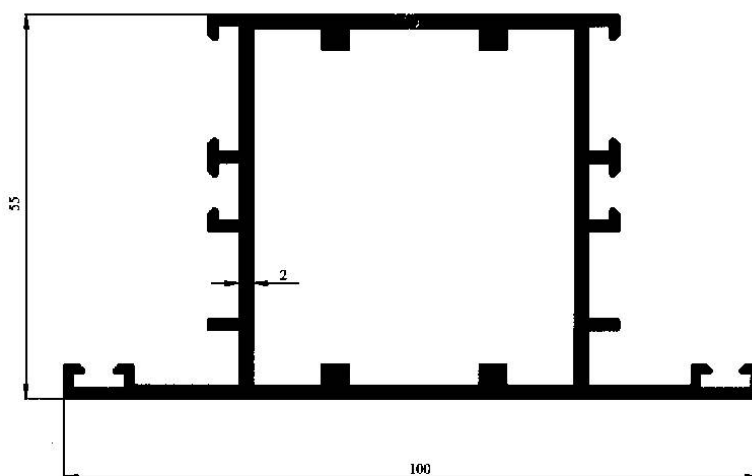

Profil No : 2505
Gramaj : 1.760 kg/m
Çevre : 441 mm

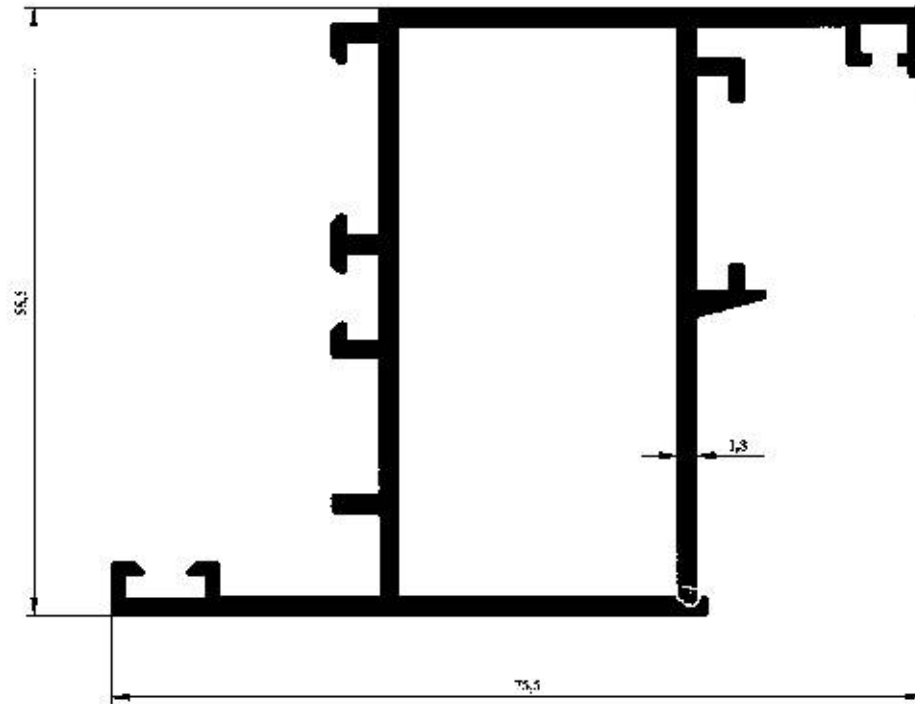

Profil No : 2501
 Gramaj : 1.271 kg/m
 Çevre : 381 mm

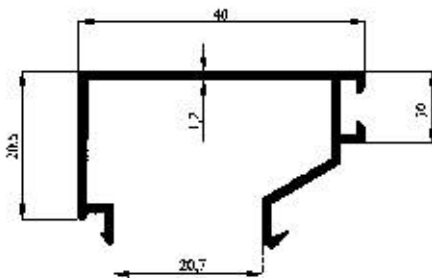

Profil No : 2506
 Gramaj : 0.341 kg/m
 Çevre : 211 mm

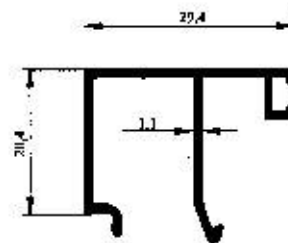

Profil No : 2521
 Gramaj : 0.274 kg/m
 Çevre : 182 mm

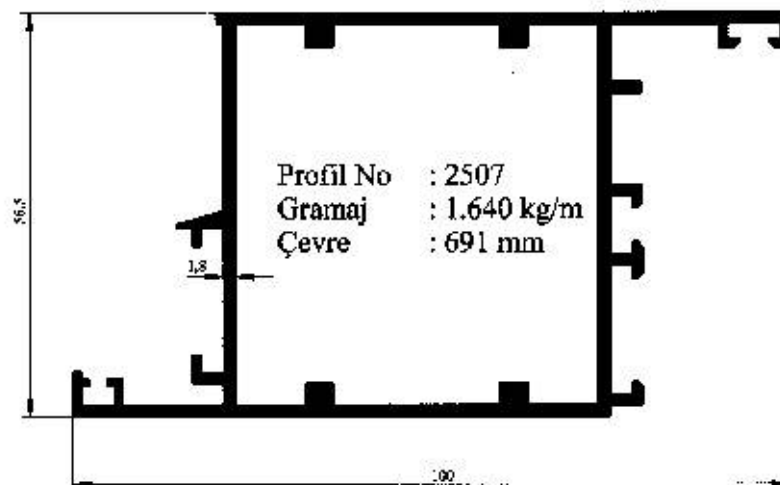

Profil No : 2507
 Gramaj : 1.640 kg/m
 Çevre : 691 mm

Hliníková okna a dveře
Windows And Doors Profiles

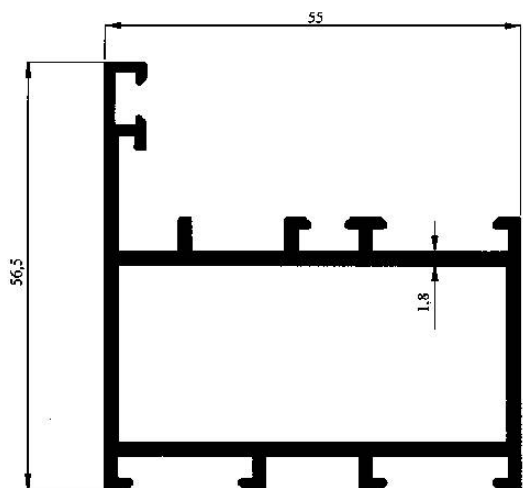

Profil No : 2508
Gramaj : 1.136 kg/m
Çevre : 335 mm

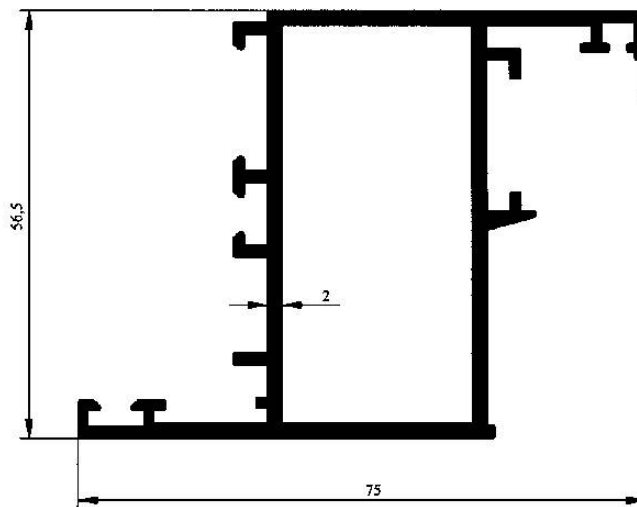

Profil No : 2509
Gramaj : 1.381 kg/m
Çevre : 389 mm

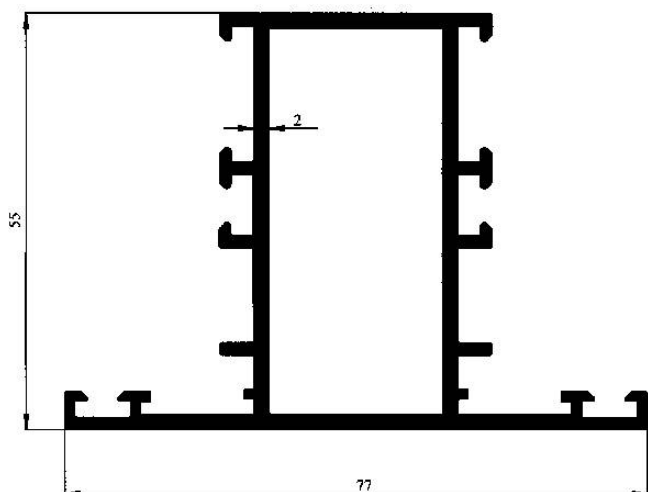

Profil No : 2510
Gramaj : 1.400 kg/m
Çevre : 406 mm

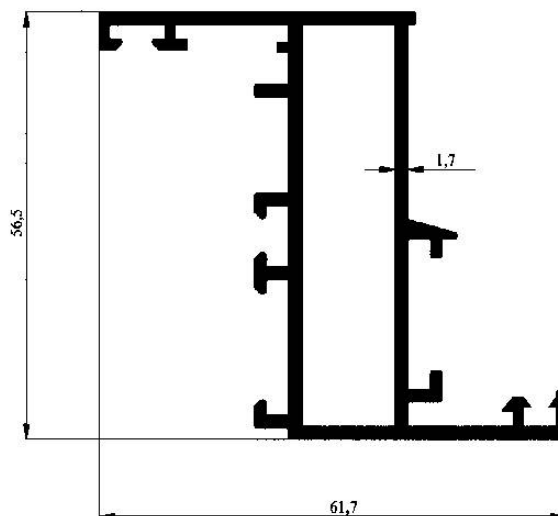

Profil No : 2511
Gramaj : 1.108 kg/m
Çevre : 361 mm

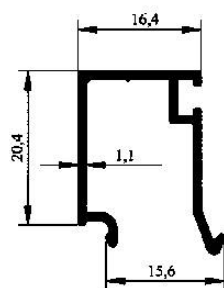

Profil No : 2522
Gramaj : 0.218 kg/m
Çevre : 145 mm

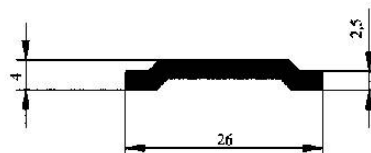

Profil No : 2523
Gramaj : 0.184 kg/m
Çevre : 59 mm

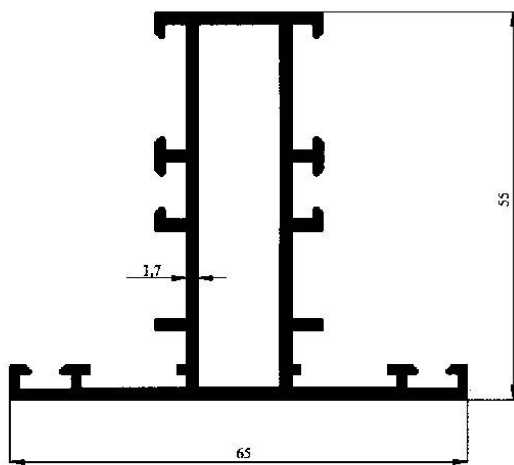

Profil No : 2512
Gramaj : 1.143 kg/m
Çevre : 383 mm

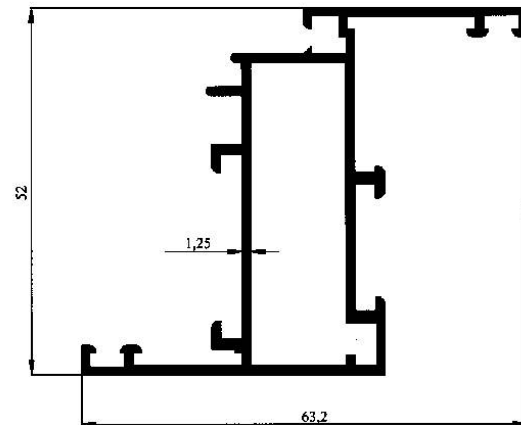

Profil No : 2519
Gramaj : 0.789 kg/m
Çevre : 349 mm

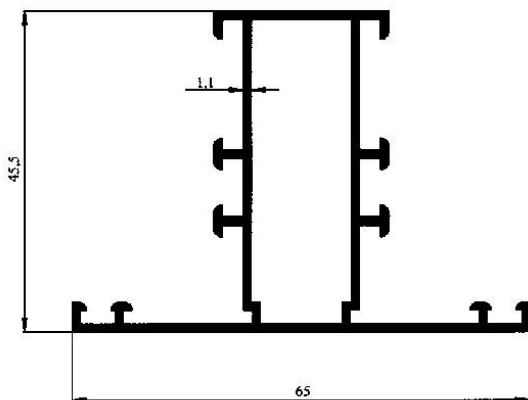

Profil No : 2520
Gramaj : 0.699 kg/m
Çevre : 343 mm

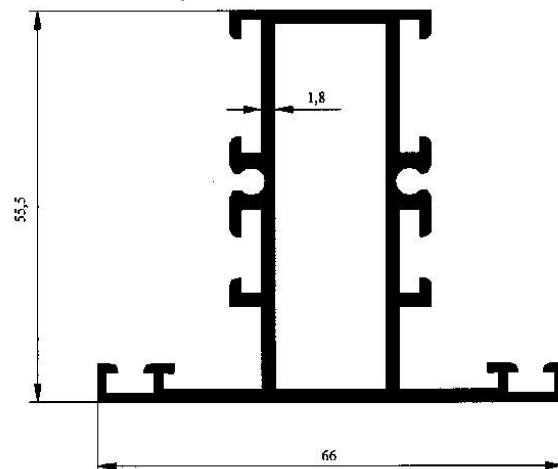

Profil No : 2527
Gramaj : 1.241 kg/m
Çevre : 404 mm

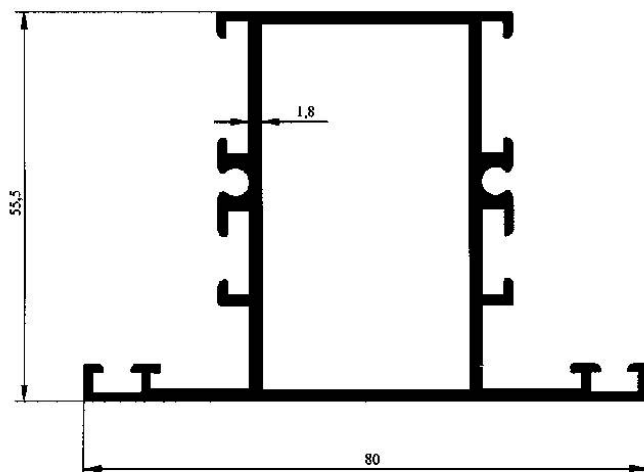

Profil No : 2528
Gramaj : 1.374 kg/m
Çevre : 588 mm

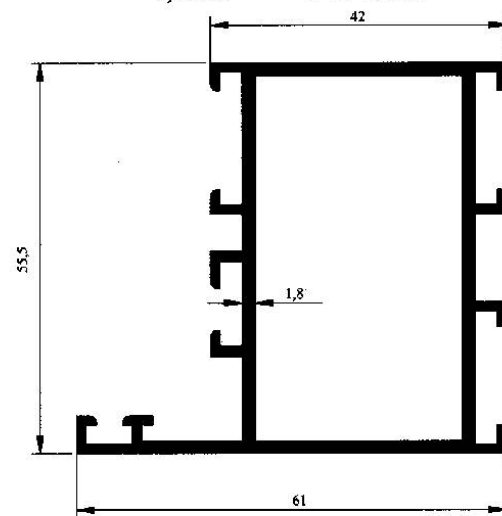

Profil No : 2529
Gramaj : 1.173 kg/m
Çevre : 357 mm

Hliníková okna a dveře
Windows And Doors Profiles

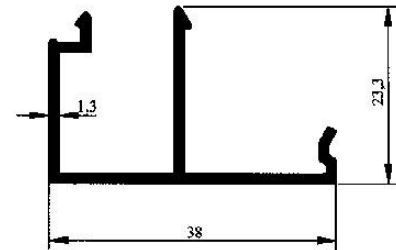
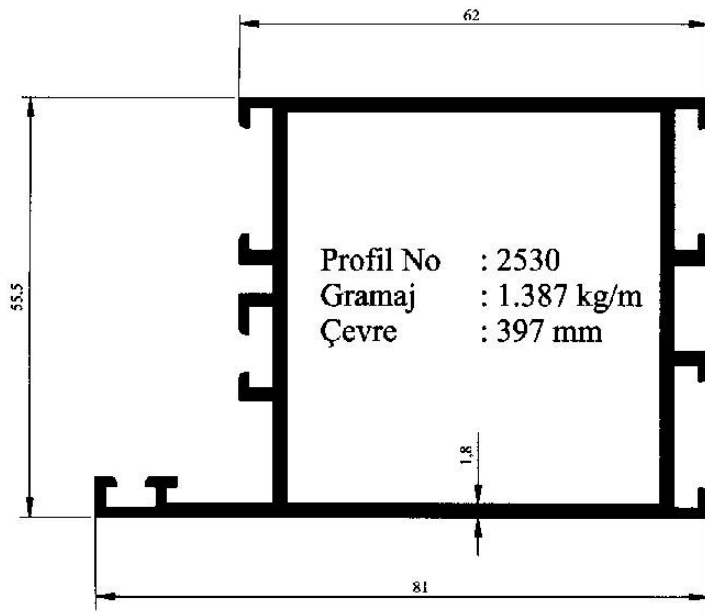

Profil No : 2532
Gramaj : 0.330 kg/m
Çevre : 188 mm

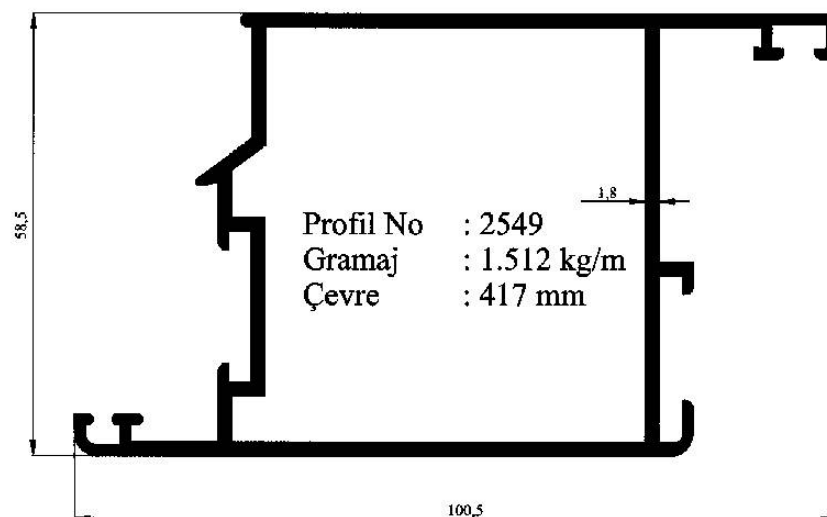
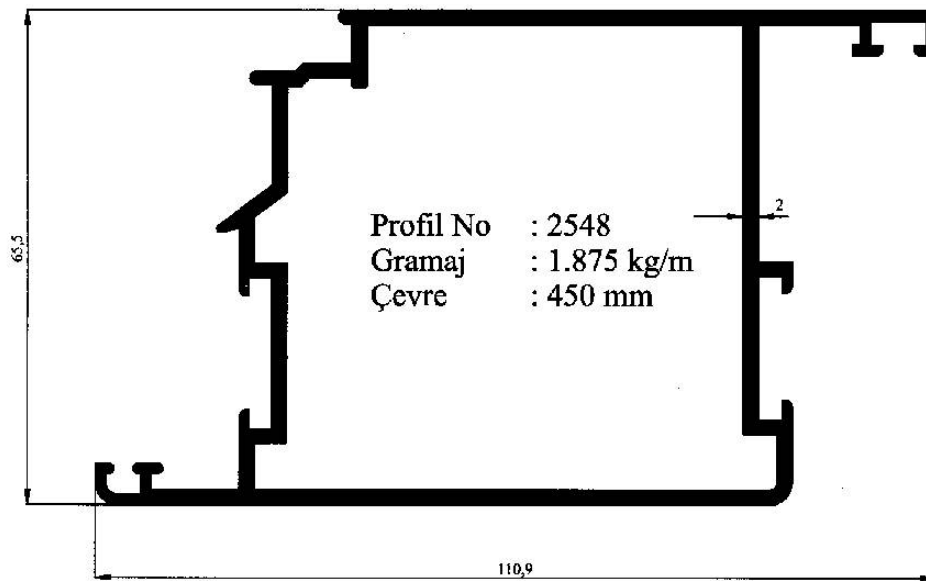



Hliníková okna a dveře
Windows And Doors Profiles

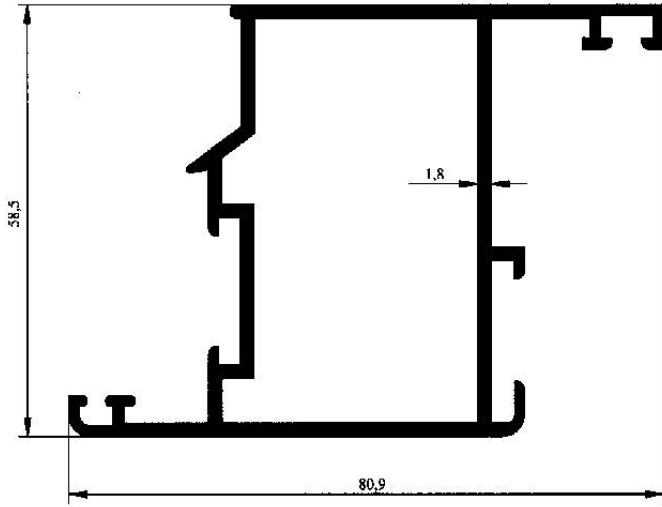

Profil No : 2550
 Gramaj : 1.322 kg/m
 Çevre : 377 mm

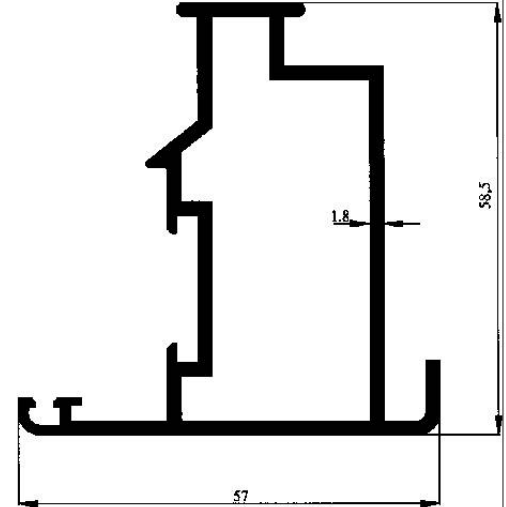

Profil No : 2552
 Gramaj : 1.100 kg/m
 Çevre : 293 mm

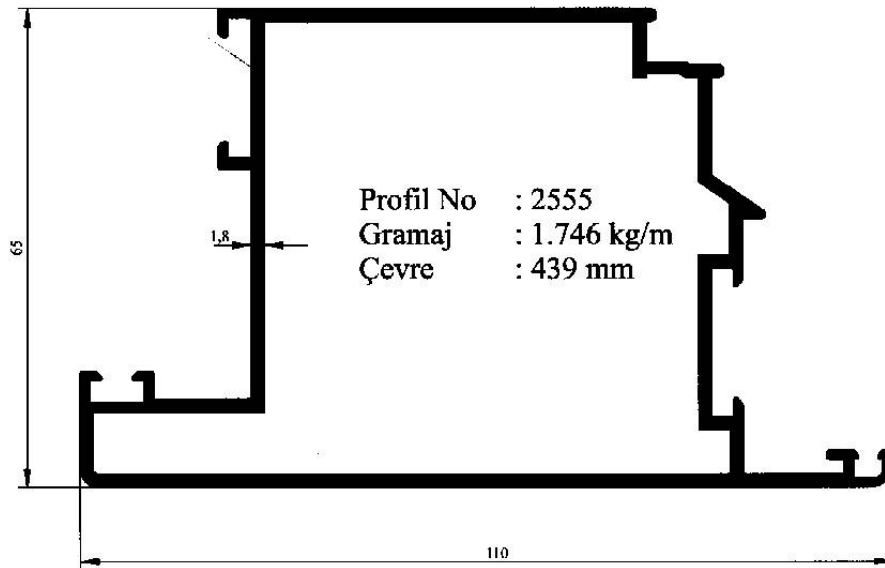

Profil No : 2555
 Gramaj : 1.746 kg/m
 Çevre : 439 mm

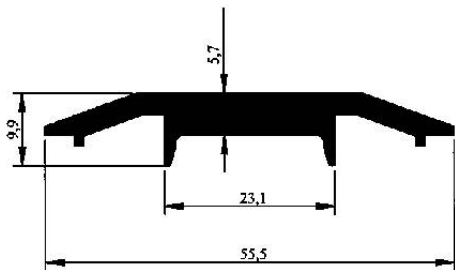

Profil No : 2568
 Gramaj : 0.643 kg/m
 Çevre : 157 mm

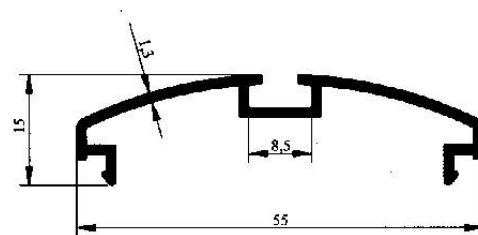

Profil No : 2569
 Gramaj : 0.331 kg/m
 Çevre : 188 mm

Hliníková okna a dveře
Windows And Doors Profiles

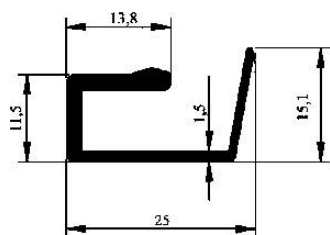

Profil No : 2574
Gramaj : 0.253 kg/m
Çevre : 118 mm

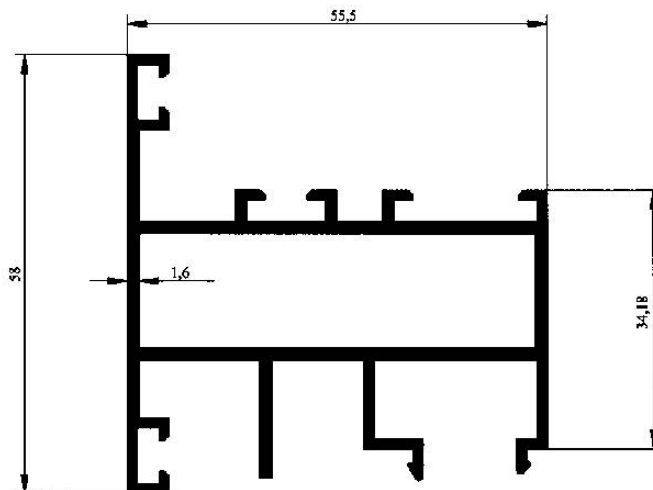

Profil No : 2575
Gramaj : 1.156 kg/m
Çevre : 435 mm

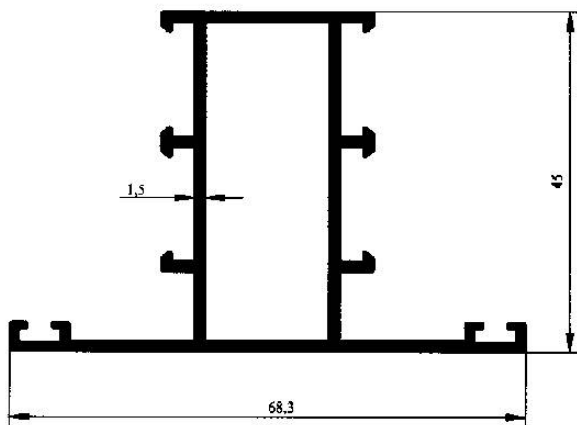

Profil No : 2577
Gramaj : 0.880 kg/m
Çevre : 323 mm

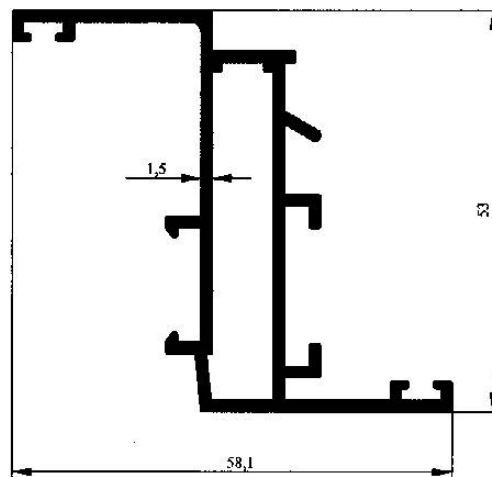

Profil No : 2578
Gramaj : 0.862 kg/m
Çevre : 314 mm

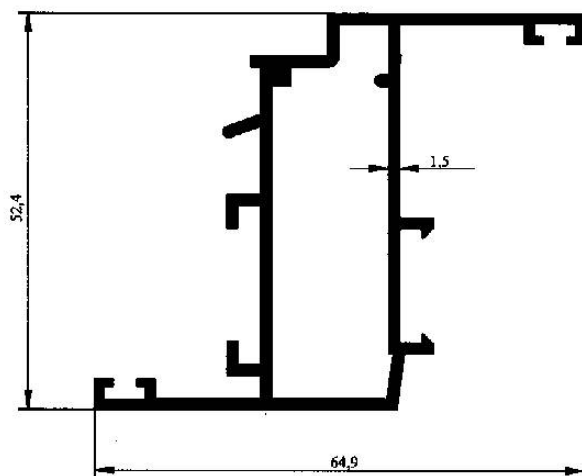

Profil No : 2579
Gramaj : 0.932 kg/m
Çevre : 328 mm

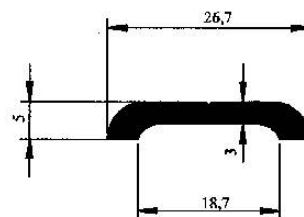

Profil No : 2580
Gramaj : 0.239 kg/m
Çevre : 61 mm

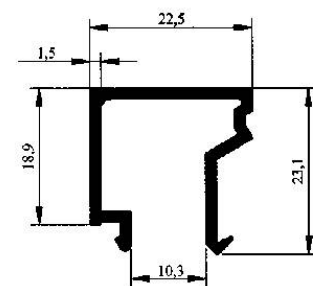
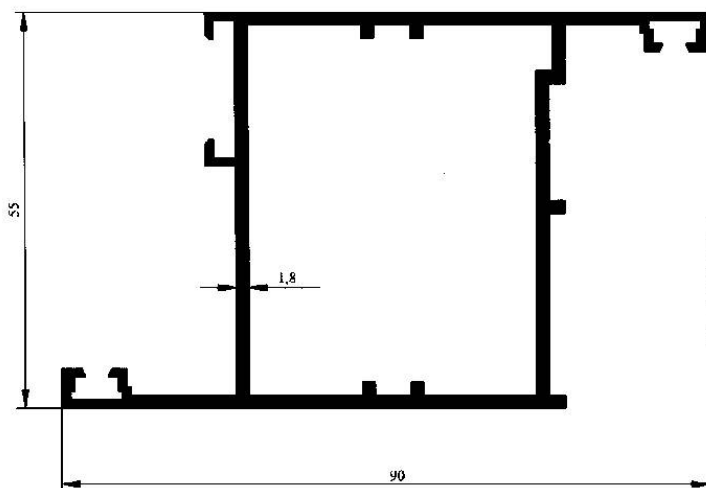
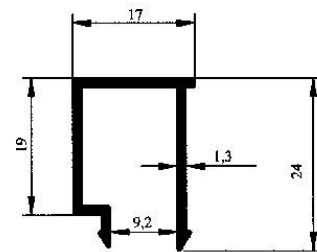
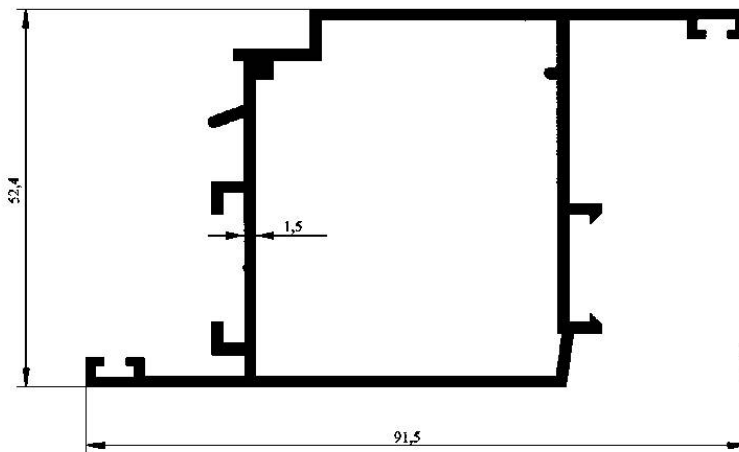
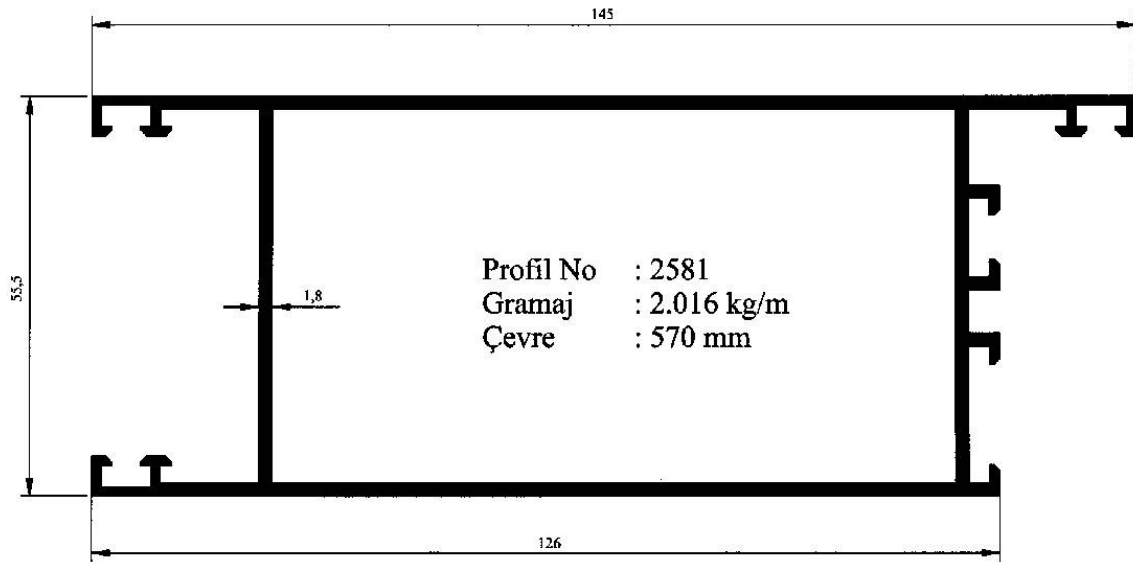

Hliníková okna a dveře
Windows And Doors Profiles

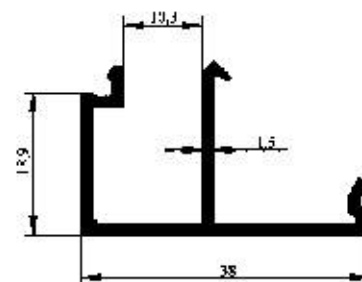
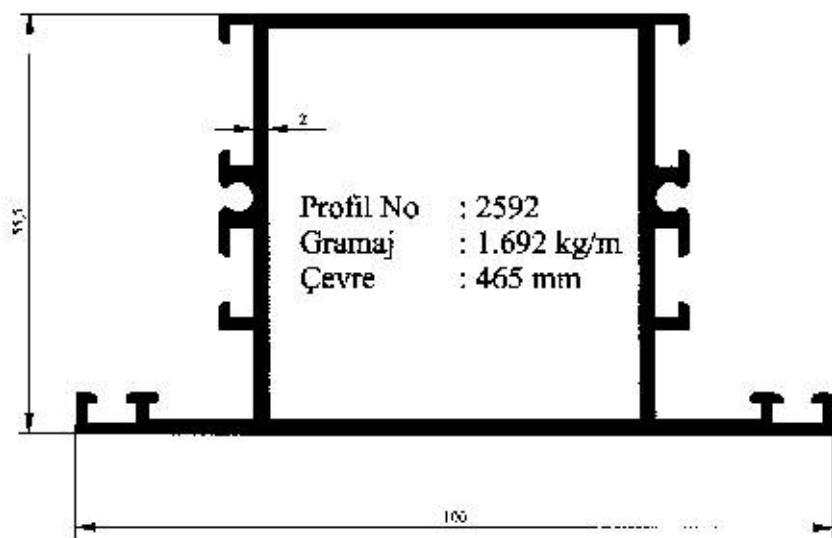

Profil No : 2595
Gramaj : 0.380 kg/m
Çevre : 189 mm

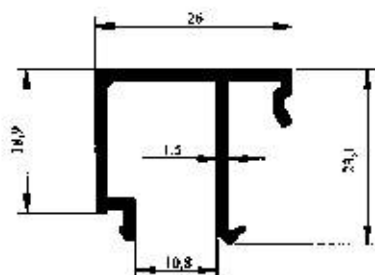
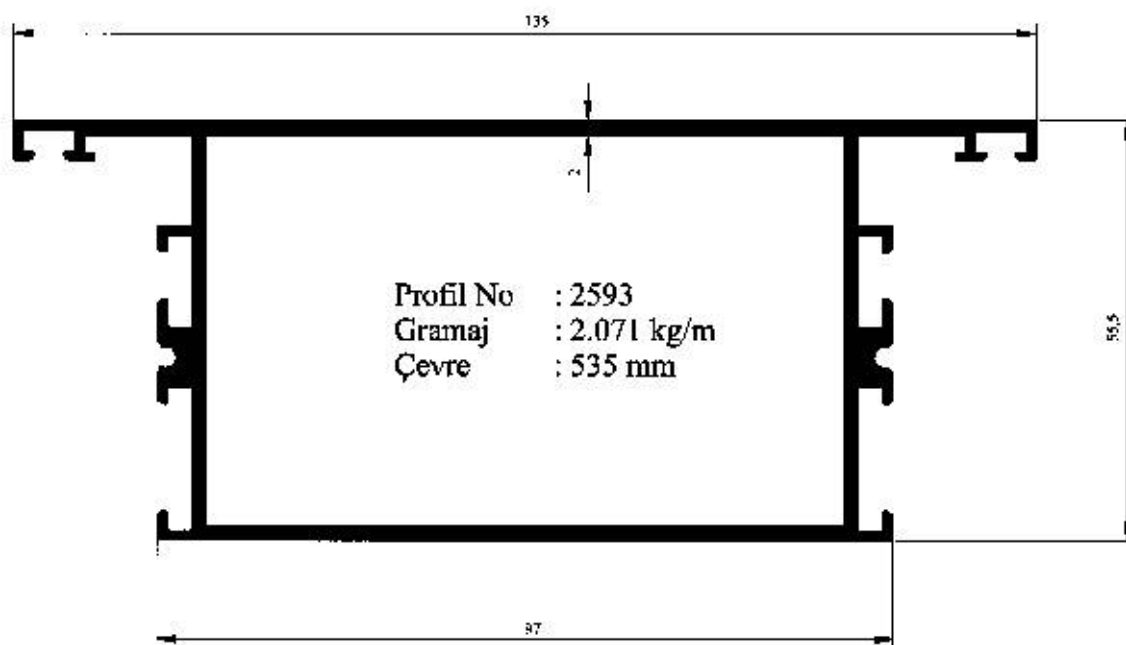

Profil No : 2596
Gramaj : 0.330 kg/m
Çevre : 164 mm

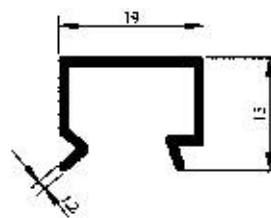

Profil No : 2600
Gramaj : 0.168 kg/m
Çevre : 110 mm

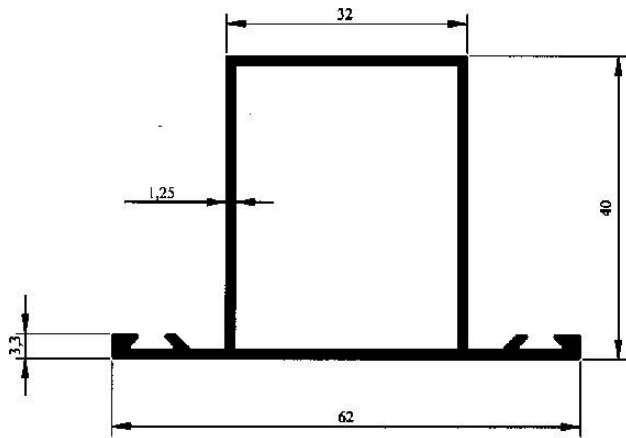

Profil No : 2601
Gramaj : 0.623 kg/m
Çevre : 222 mm

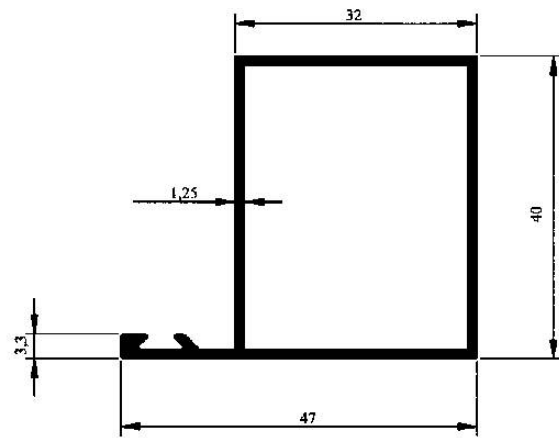

Profil No : 2602
Gramaj : 0.547 kg/m
Çevre : 183 mm

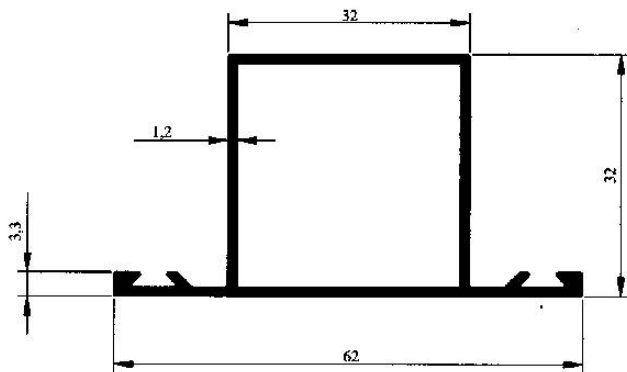

Profil No : 2603
Gramaj : 0.569 kg/m
Çevre : 206 mm

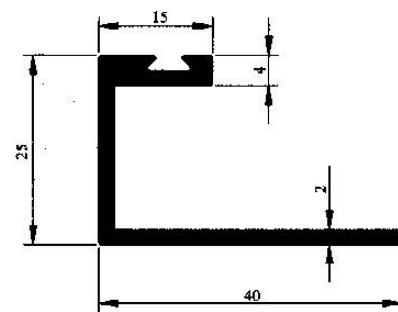

Profil No : 2608
Gramaj : 0.458 kg/m
Çevre : 162 mm

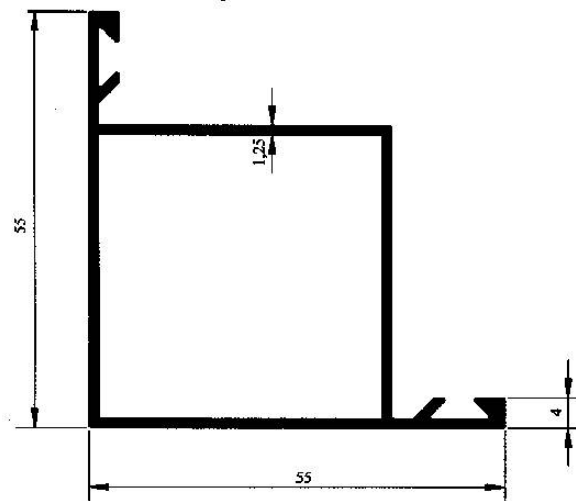

Profil No : 2623
Gramaj : 0.699 kg/m
Çevre : 247 mm

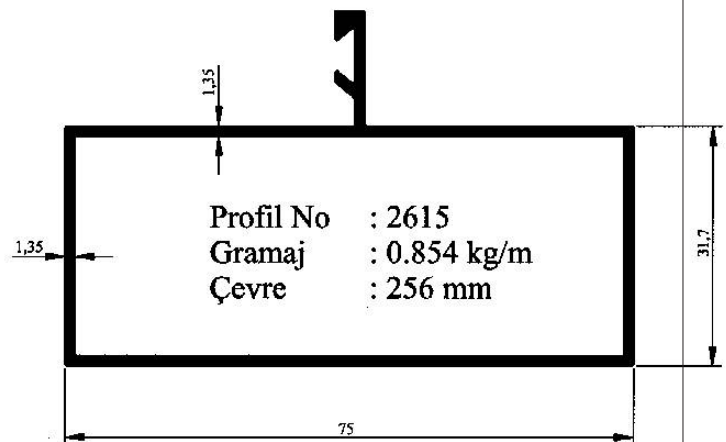

Profil No : 2615
Gramaj : 0.854 kg/m
Çevre : 256 mm

Hliníková okna a dveře
Windows And Doors Profiles

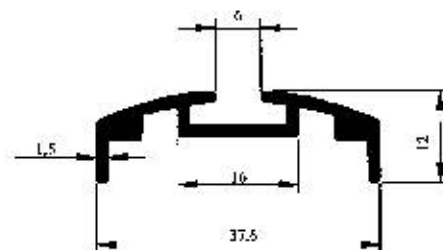
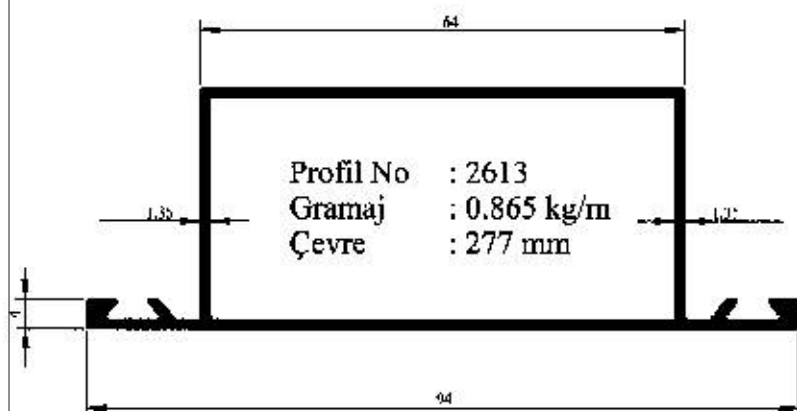

Profil No : 2611
 Gramaj : 0.331 kg/m
 Çevre : 137 mm

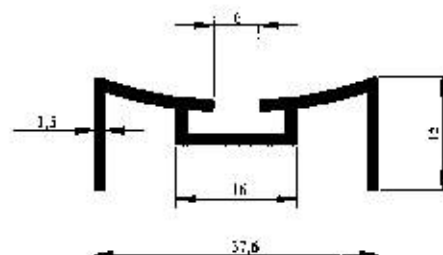
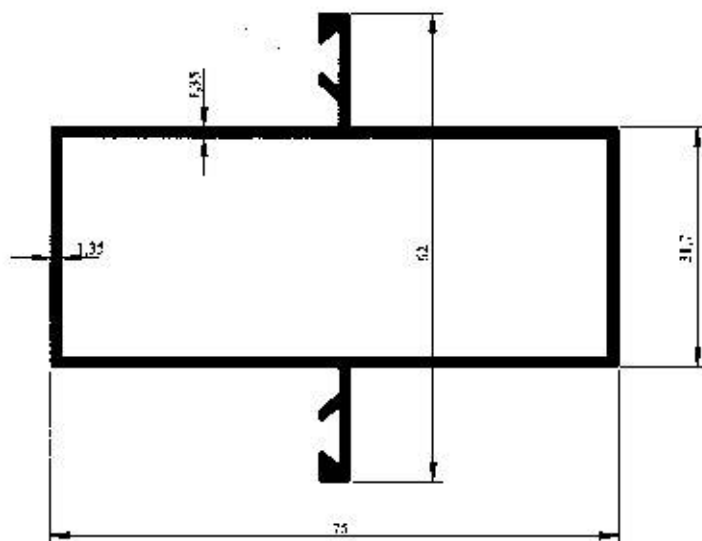

Profil No : 2612
 Gramaj : 0.331 kg/m
 Çevre : 163 mm

Profil No : 2614
 Gramaj : 0.943 kg/m
 Çevre : 298 mm

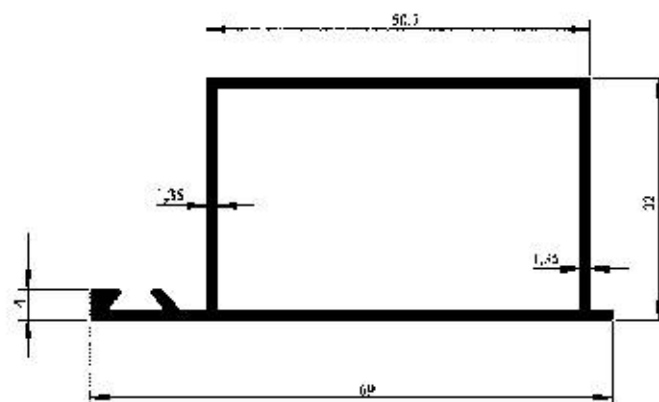
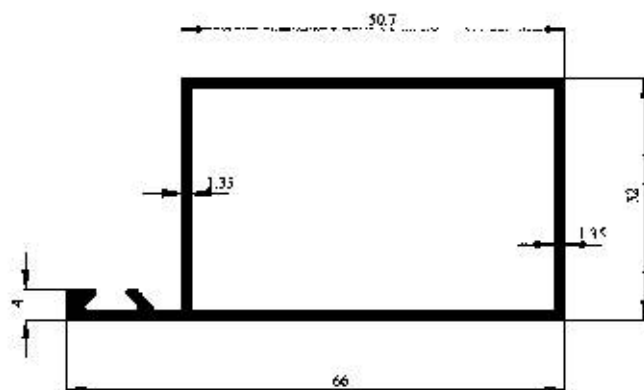

Profil No : 2616
 Gramaj : 0.678 kg/m
 Çevre : 208 mm

Profil No : 2617
 Gramaj : 0.688 kg/m
 Çevre : 214 mm

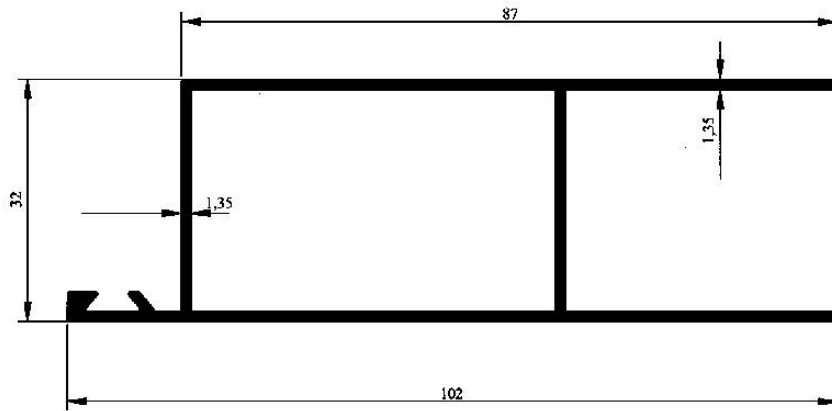

Profil No : 2618
Gramaj : 0.940 kg/m
Çevre : 352 mm

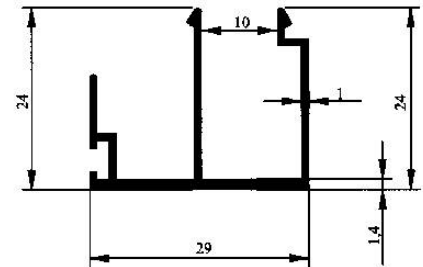

Profil No : 2944
Gramaj : 0.296 kg/m
Çevre : 195 mm

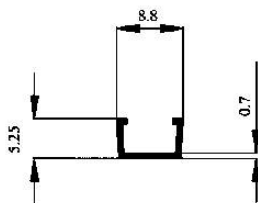

Profil No : 3097
Gramaj : 0.036 kg/m
Çevre : 38 mm

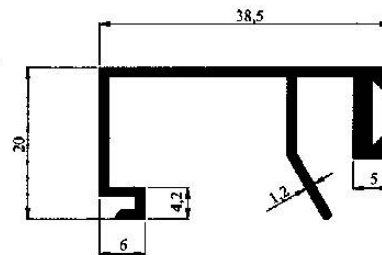

Profil No : 3210
Gramaj : 0.377 kg/m
Çevre : 205 mm

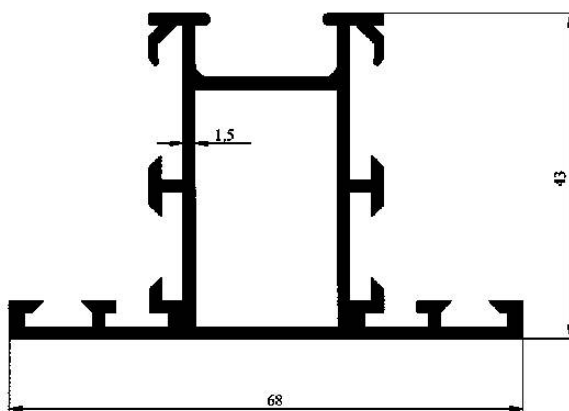

Profil No : 3211
Gramaj : 1.042 kg/m
Çevre : 393 mm

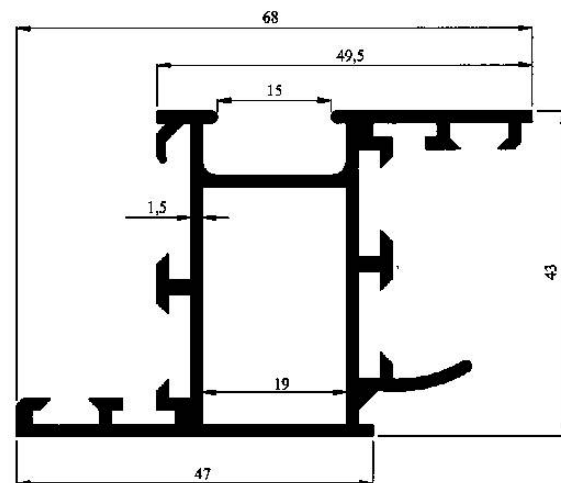

Profil No : 3212
Gramaj : 1.087 kg/m
Çevre : 404 mm

Hliníková okna a dveře
Windows And Doors Profiles

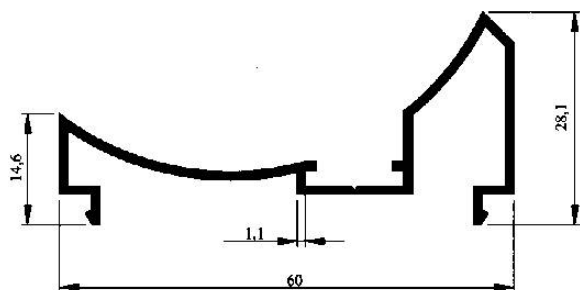

Profil No : 3215
Gramaj : 0.391 kg/m
Çevre : 264 mm

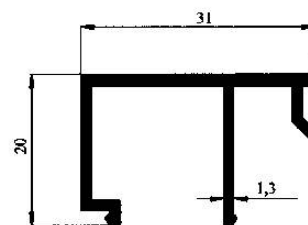

Profil No : 3297
Gramaj : 0.312 kg/m
Çevre : 160 mm

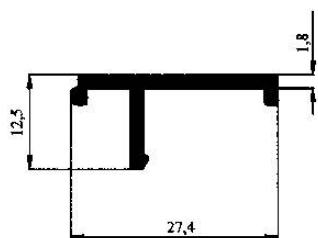

Profil No : 3298
Gramaj : 0.206 kg/m
Çevre : 87 mm

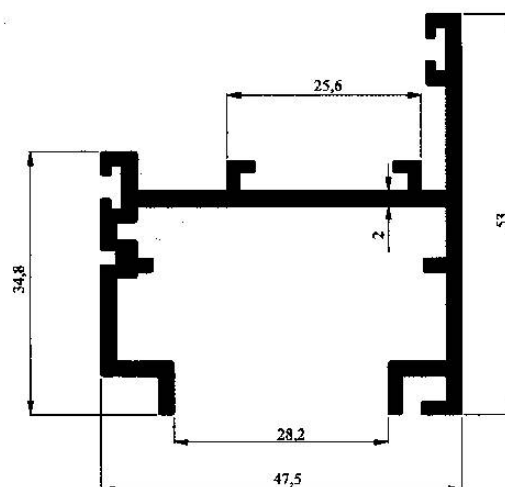

Profil No : 3299
Gramaj : 0.995 kg/m
Çevre : 381 mm

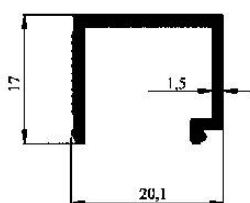

Profil No : 3301
Gramaj : 0.222 kg/m
Çevre : 110 mm

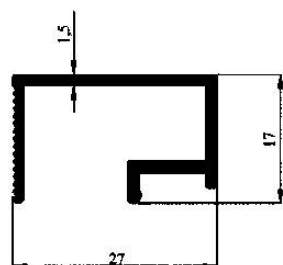

Profil No : 3306
Gramaj : 0.276 kg/m
Çevre : 148 mm

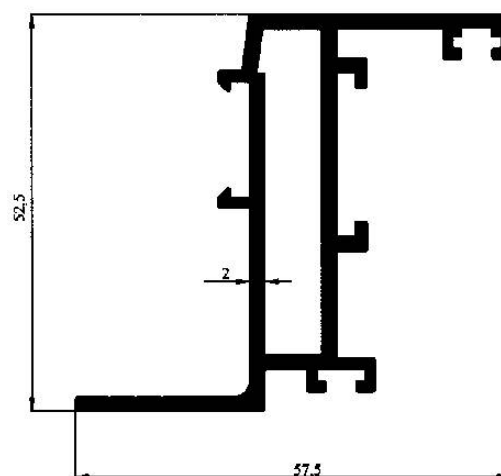

Profil No : 3309
Gramaj : 1.068 kg/m
Çevre : 307 mm

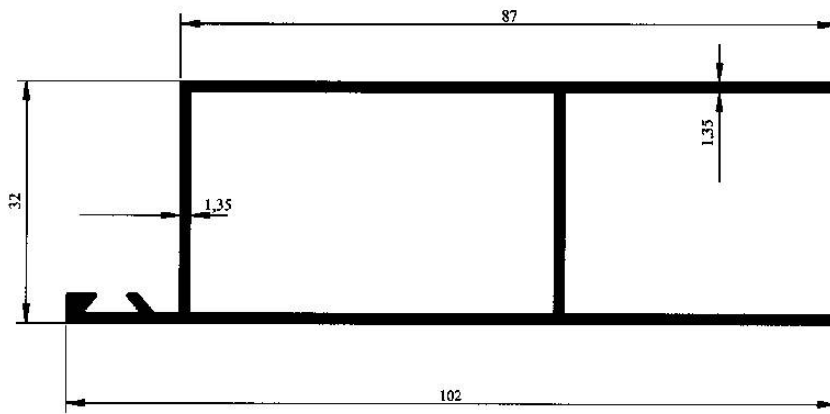

Profil No : 2618
Gramaj : 0.940 kg/m
Çevre : 352 mm

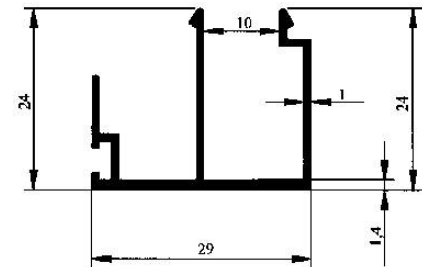

Profil No : 2944
Gramaj : 0.296 kg/m
Çevre : 195 mm

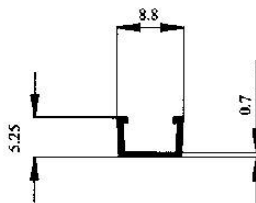

Profil No : 3097
Gramaj : 0.036 kg/m
Çevre : 38 mm

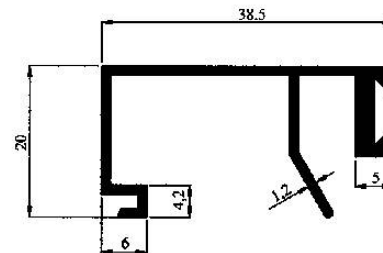

Profil No : 3210
Gramaj : 0.377 kg/m
Çevre : 205 mm

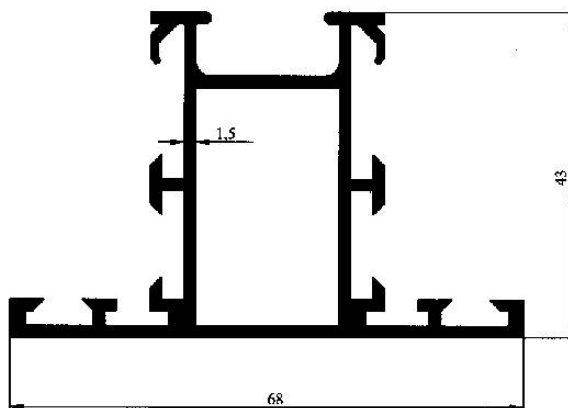

Profil No : 3211
Gramaj : 1.042 kg/m
Çevre : 393 mm

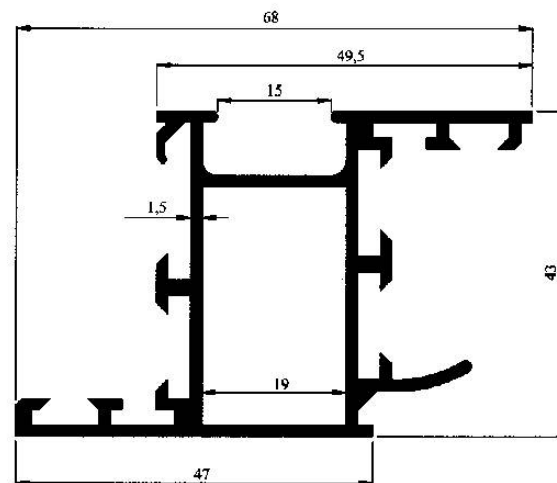

Profil No : 3212
Gramaj : 1.087 kg/m
Çevre : 404 mm

Hliníková okna a dveře
Windows And Doors Profiles

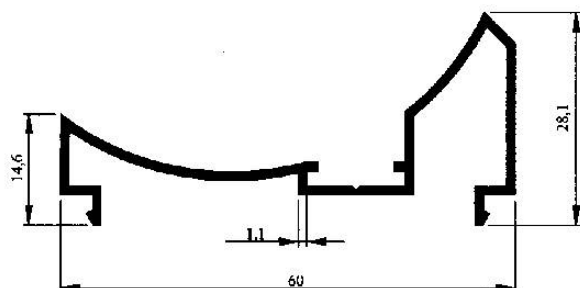

Profil No : 3215
Gramaj : 0.391 kg/m
Çevre : 264 mm

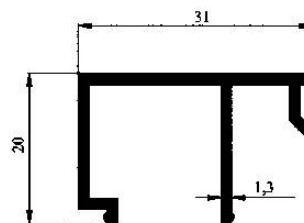

Profil No : 3297
Gramaj : 0.312 kg/m
Çevre : 160 mm

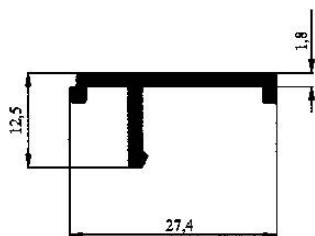

Profil No : 3298
Gramaj : 0.206 kg/m
Çevre : 87 mm

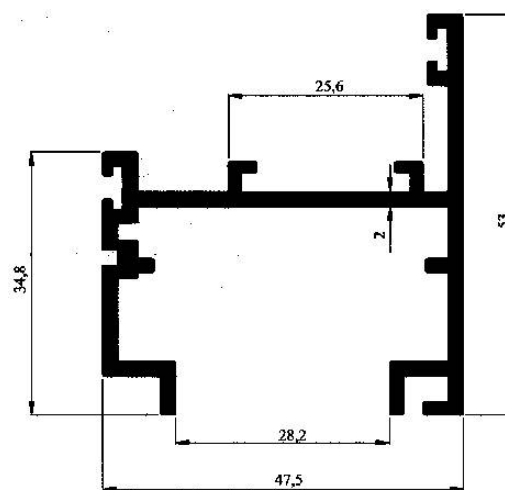

Profil No : 3299
Gramaj : 0.995 kg/m
Çevre : 381 mm

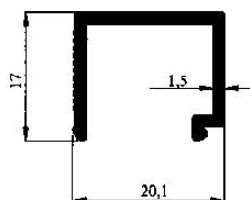

Profil No : 3301
Gramaj : 0.222 kg/m
Çevre : 110 mm

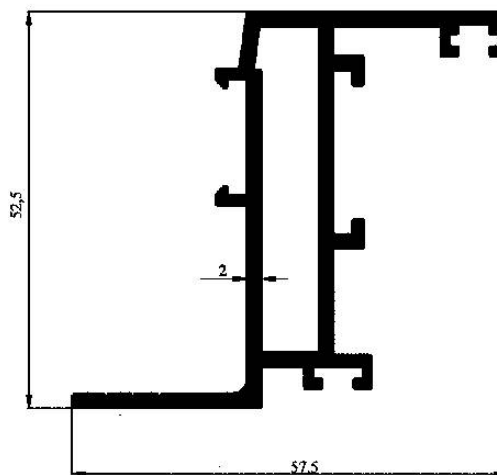

Profil No : 3309
Gramaj : 1.068 kg/m
Çevre : 307 mm

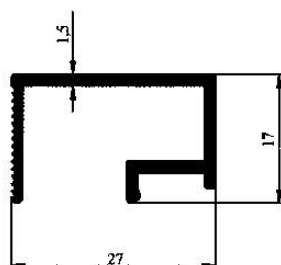

Profil No : 3306
Gramaj : 0.276 kg/m
Çevre : 148 mm

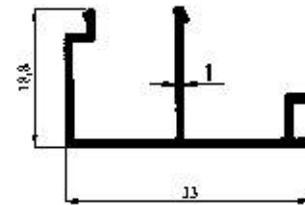
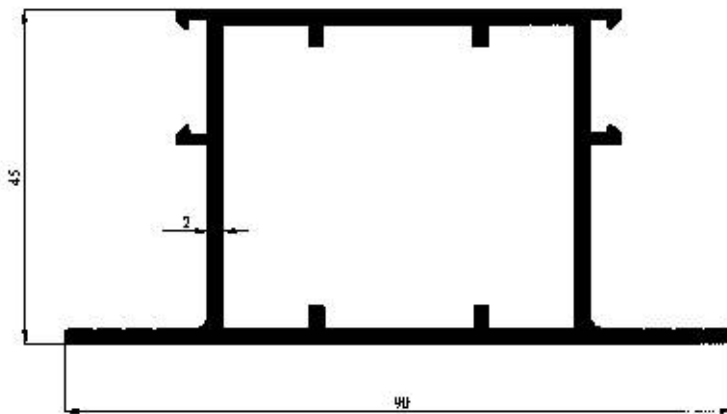

Profil No : 3312
Gramaj : 0.249 kg/m
Çevre : 161 mm

Profil No : 3311
Gramaj : 1.360 kg/m
Çevre : 309 mm

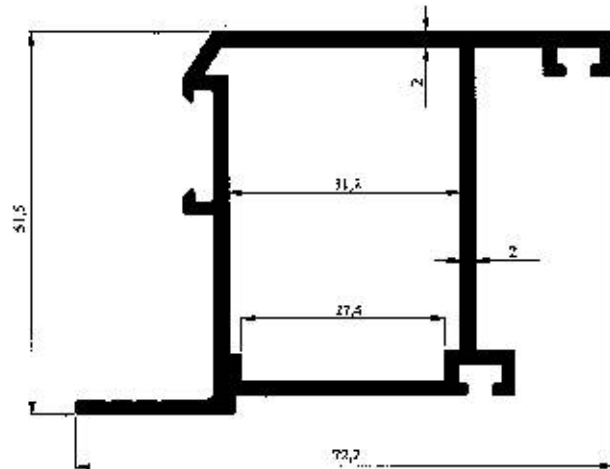
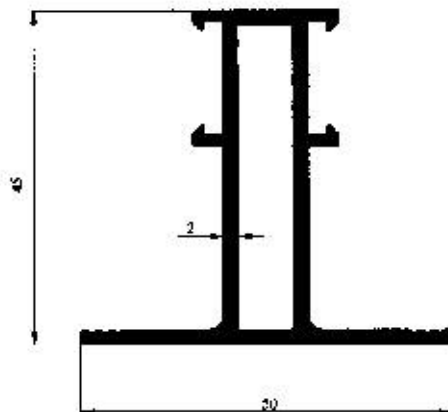

Profil No : 3317
Gramaj : 1.260 kg/m
Çevre : 308 mm

Profil No : 3316
Gramaj : 0.859 kg/m
Çevre : 233 mm

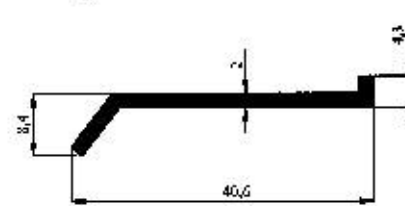

Profil No : 3334
Gramaj : 0.247 kg/m
Çevre : 95 mm

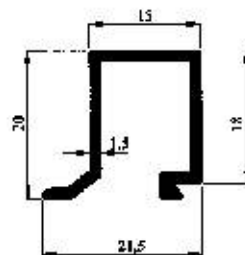

Profil No : 3329
Gramaj : 0.247 kg/m
Çevre : 127 mm

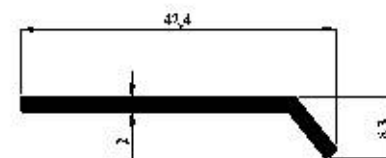

Profil No : 3340
Gramaj : 0.244 kg/m
Çevre : 94 mm

Hliníková okna a dveře
Windows And Doors Profiles

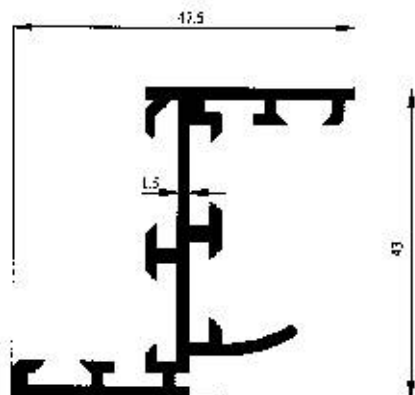

Profil No : 3429
Gramaj : 0.710 kg/m
Çevre : 342 mm

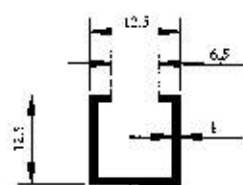

Profil No : 3432
Gramaj : 0.107 kg/m
Çevre : 81 mm

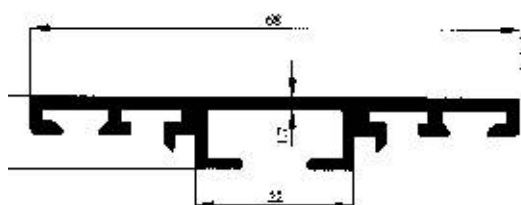

Profil No : 3435
Gramaj : 0.596 kg/m
Çevre : 258 mm

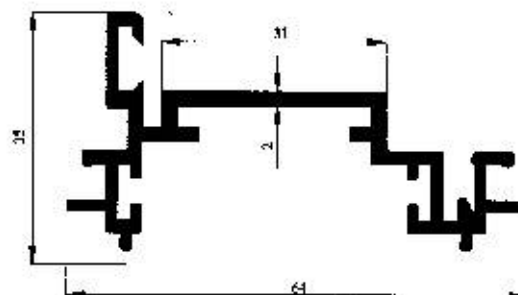

Profil No : 3433
Gramaj : 0.832 kg/m
Çevre : 349 mm

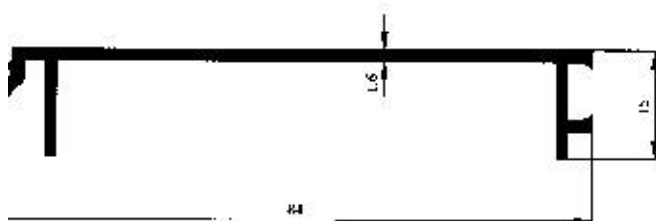

Profil No : 3438
Gramaj : 0.523 kg/m
Çevre : 242 mm

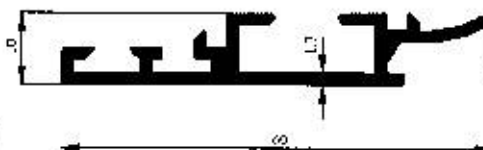

Profil No : 3437
Gramaj : 0.491 kg/m
Çevre : 218 mm

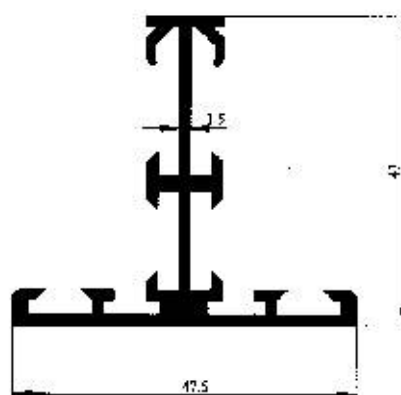

Profil No : 3439
Gramaj : 0.702 kg/m
Çevre : 322 mm

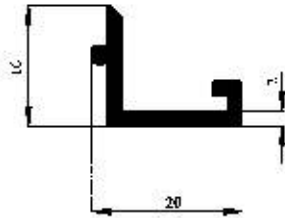

Profil No : 3466
Gramaj : 0.214 kg/m
Çevre : 82 mm

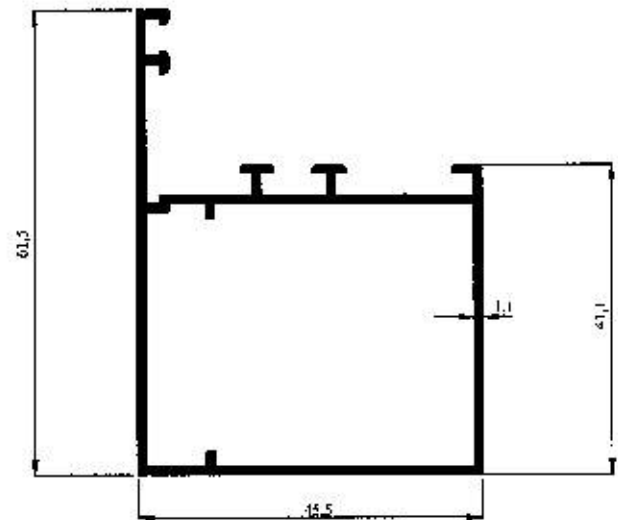

Profil No : 2515
Gramaj : 0.657 kg/m
Çevre : 276 mm

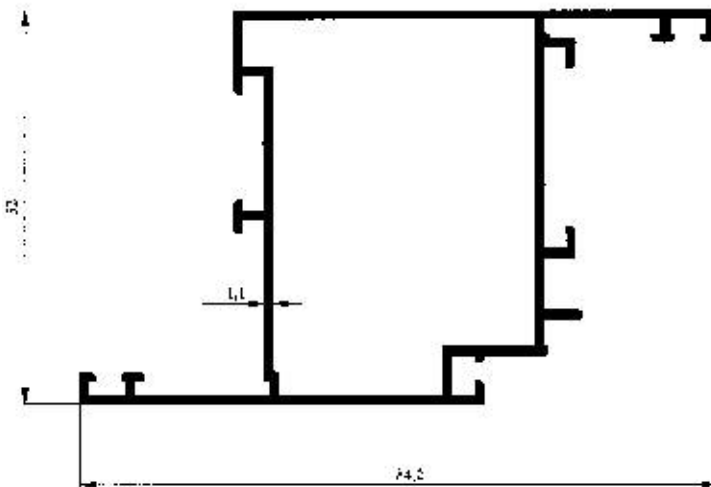

Profil No : 2516
Gramaj : 0.851 kg/m
Çevre : 387 mm

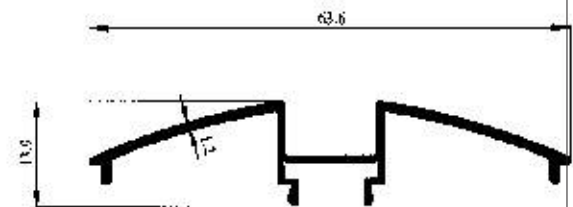

Profil No : 4560
Gramaj : 0.297 kg/m
Çevre : 201 mm

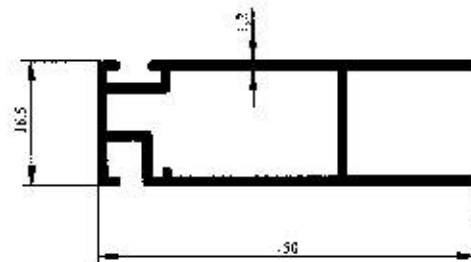

Profil No : 4339
Gramaj : 0.501 kg/m
Çevre : 190 mm

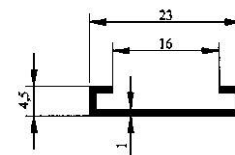
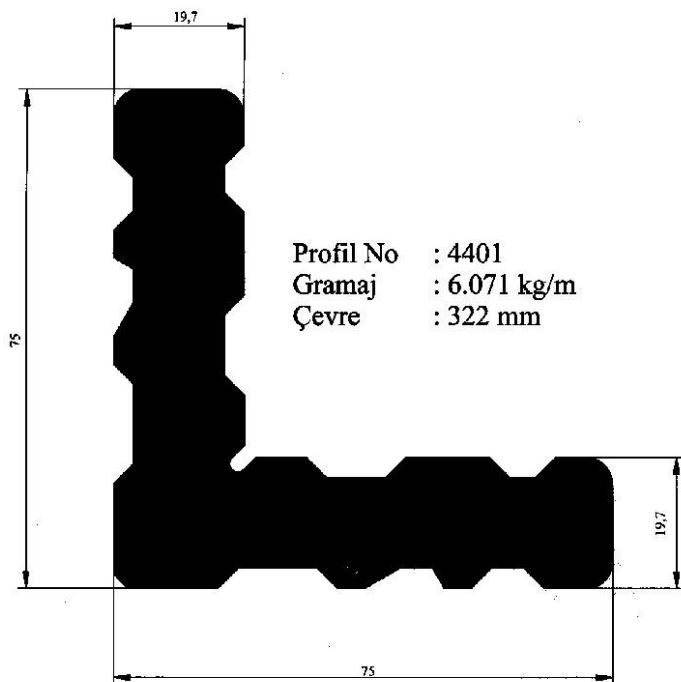

Profil No : 3667
Gramaj : 0.095 kg/m
Çevre : 72 mm

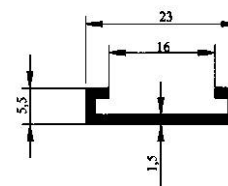

Profil No : 3668
Gramaj : 0.142 kg/m
Çevre : 73 mm

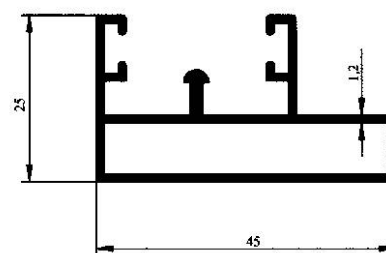
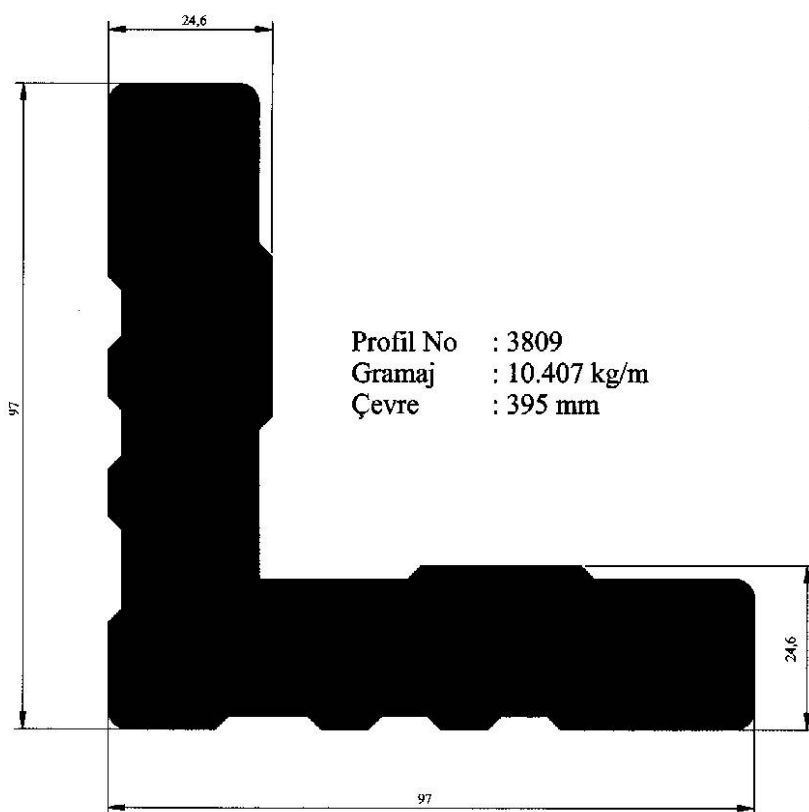

Profil No : 4340
Gramaj : 0.545 kg/m
Çevre : 223 mm

Hliníková okna a dveře
Windows And Doors Profiles

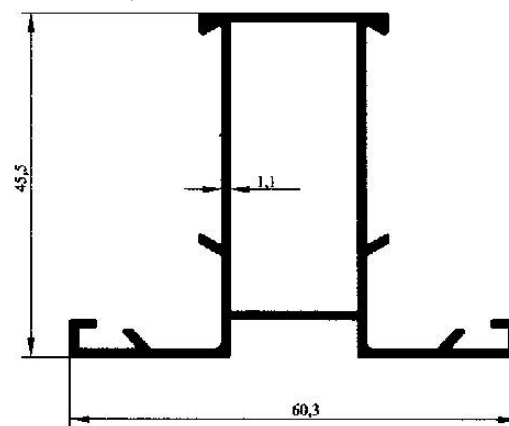
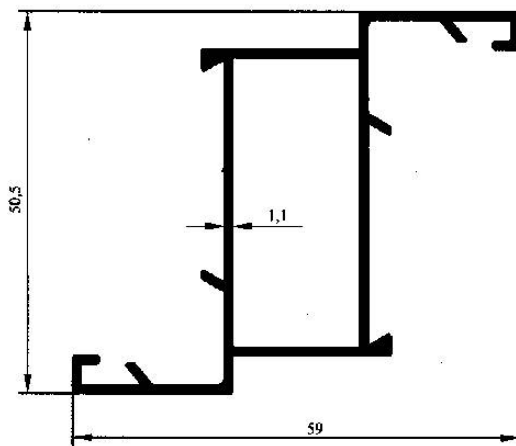
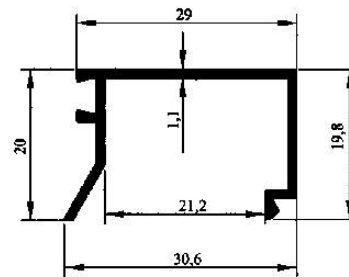
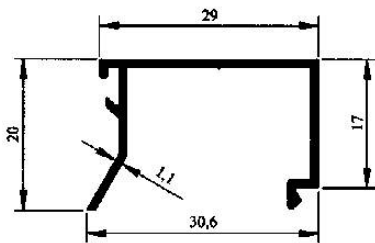
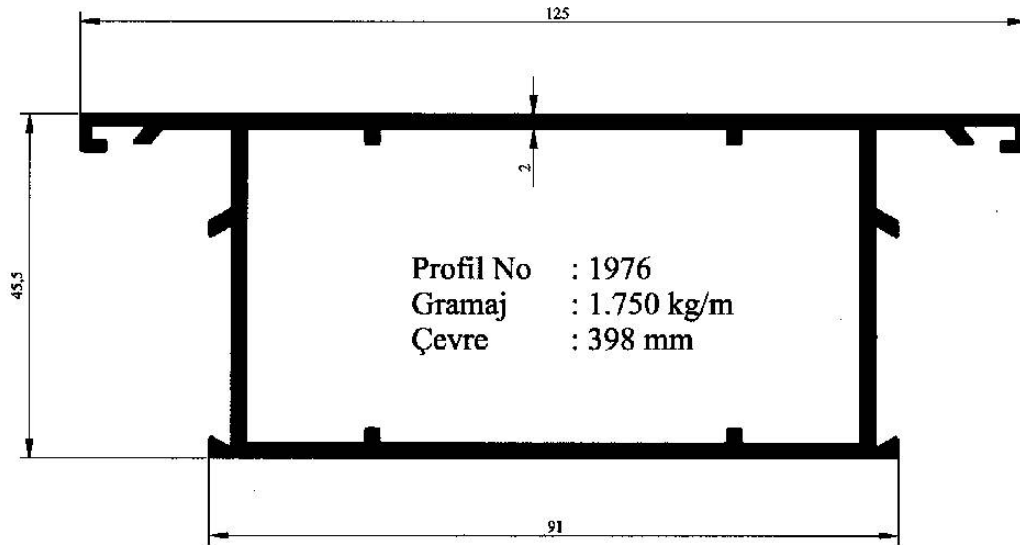

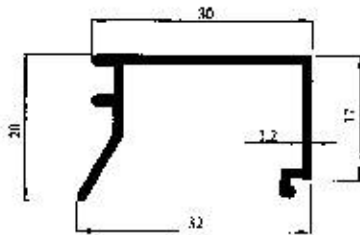

Profil No : 2003
Gramaj : 0.249 kg/m
Çevre : 151 mm

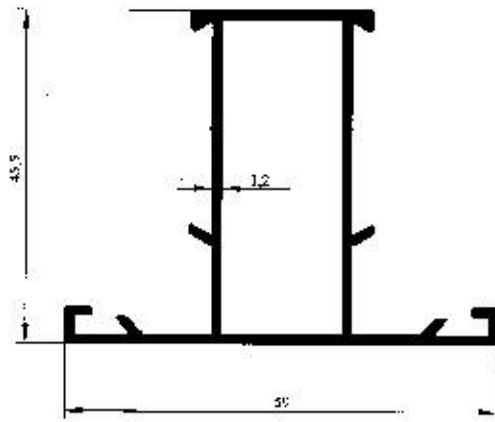

Profil No : 2007
Gramaj : 0.655 kg/m
Çevre : 270 mm

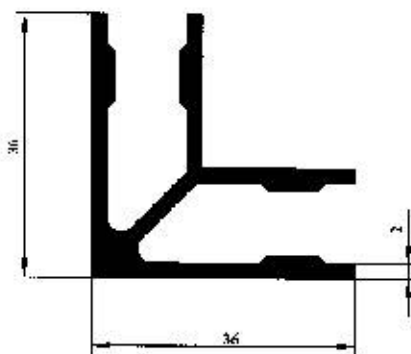

Profil No : 2010
Gramaj : 0.815 kg/m
Çevre : 254 mm

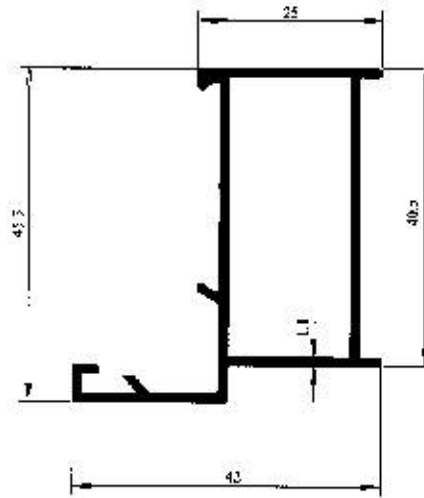

Profil No : 2006
Gramaj : 0.493 kg/m
Çevre : 211 mm

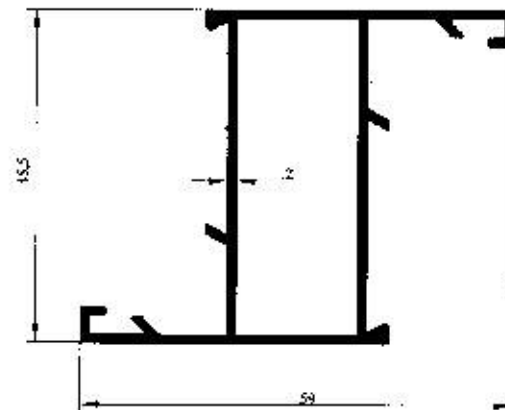

Profil No : 2008
Gramaj : 0.655 kg/m
Çevre : 270 mm

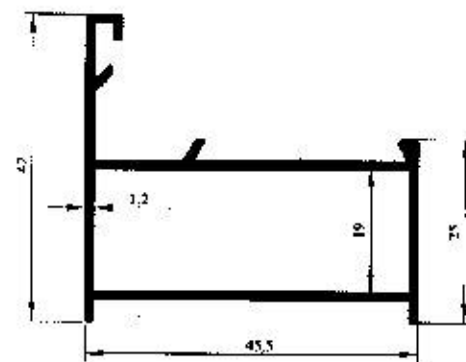

Profil No : 2009
Gramaj : 0.549 kg/m
Çevre : 211 mm

Hliníková okna a dveře
Windows And Doors Profiles

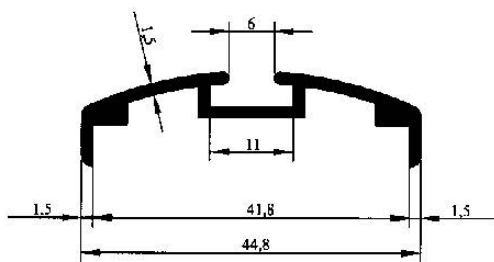

Profil No : 2011
Gramaj : 0.341 kg/m
Çevre : 146 mm

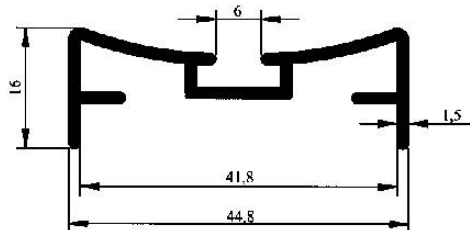

Profil No : 2012
Gramaj : 0.404 kg/m
Çevre : 199 mm

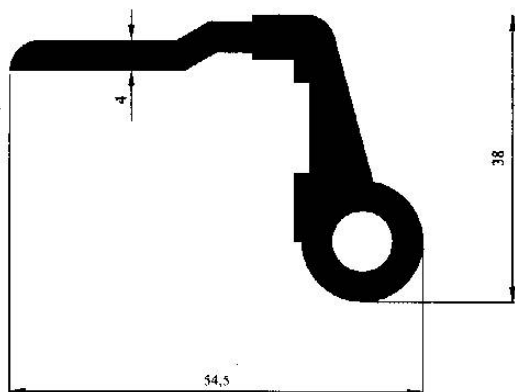

Profil No : 2013
Gramaj : 1.276 kg/m
Çevre : 172 mm



Profil No : 2014
Gramaj : 0.934 kg/m
Çevre : 138 mm

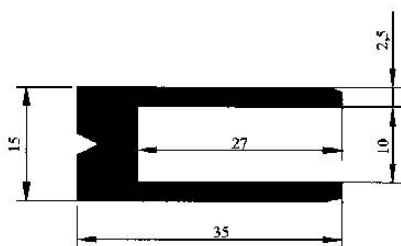

Profil No : 2015
Gramaj : 0.676 kg/m
Çevre : 157 mm

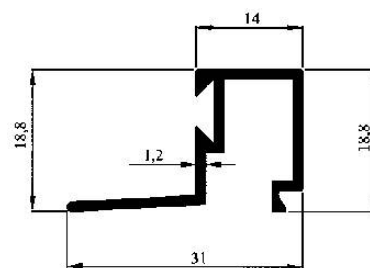

Profil No : 2018
Gramaj : 0.244 kg/m
Çevre : 150 mm

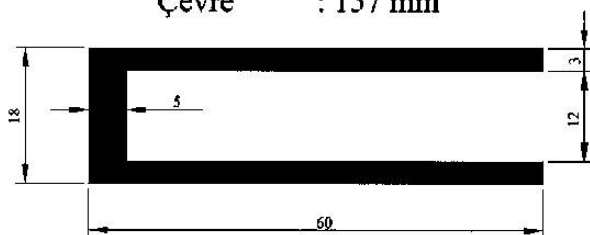

Profil No : 2016
Gramaj : 1.138 kg/m
Çevre : 266 mm

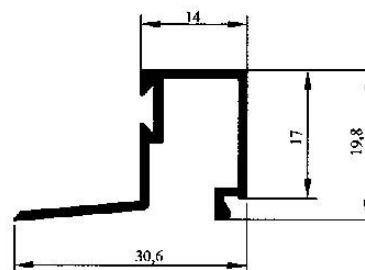

Profil No : 2017
Gramaj : 0.229 kg/m
Çevre : 151 mm

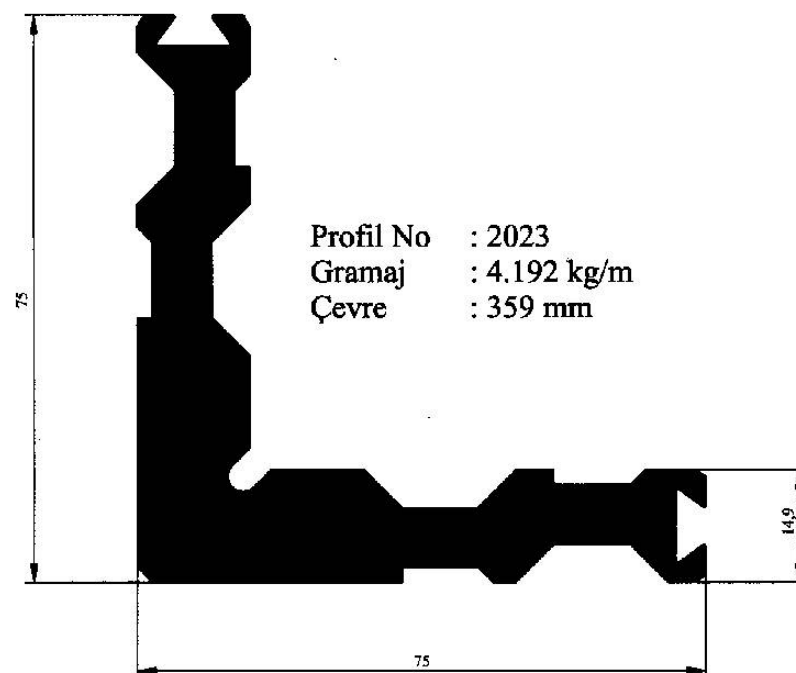
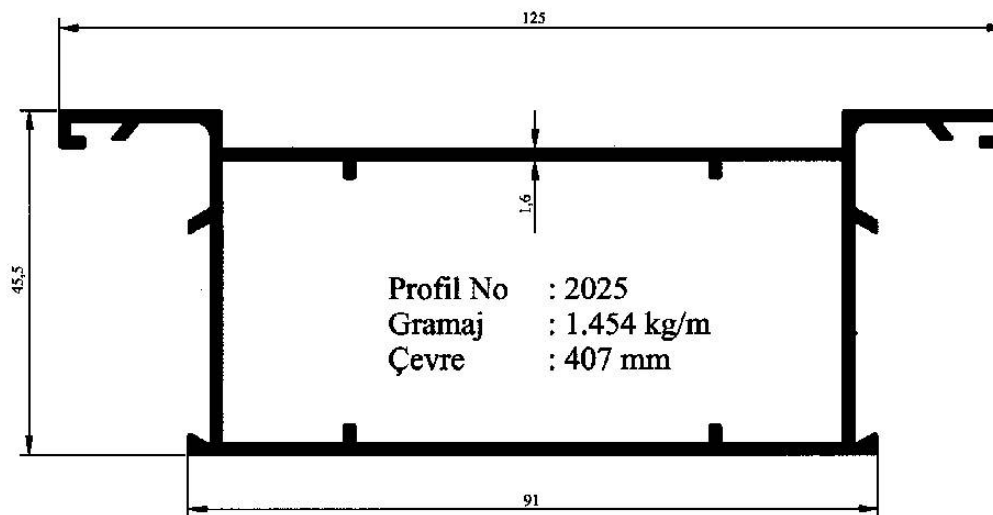
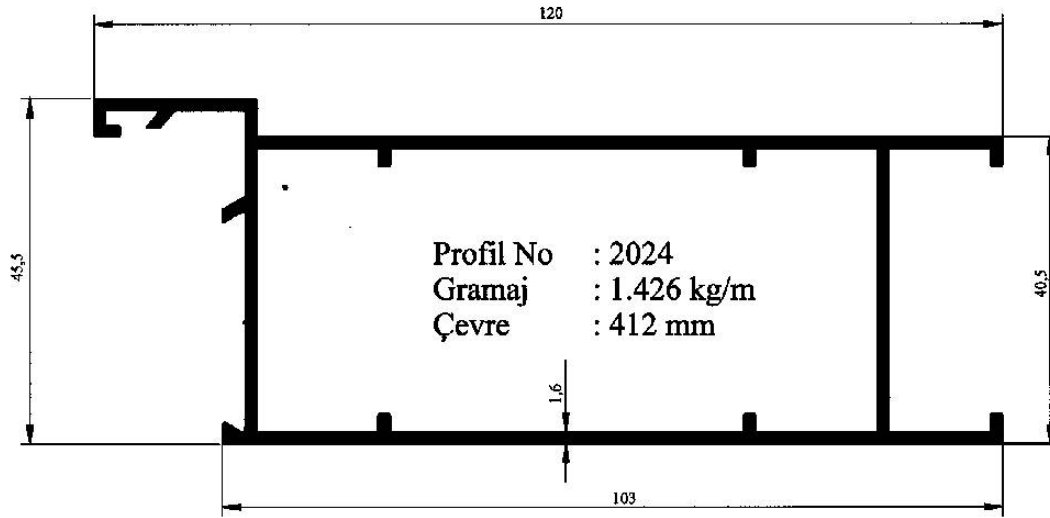

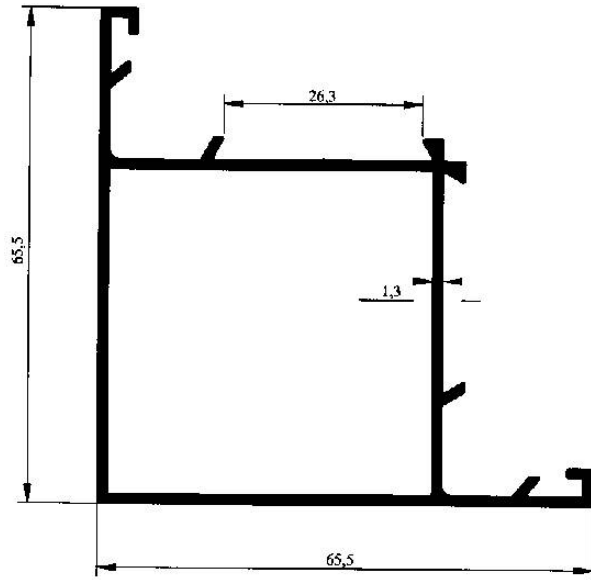

Profil No : 2027
 Gramaj : 0.892 kg/m
 Çevre : 322 mm

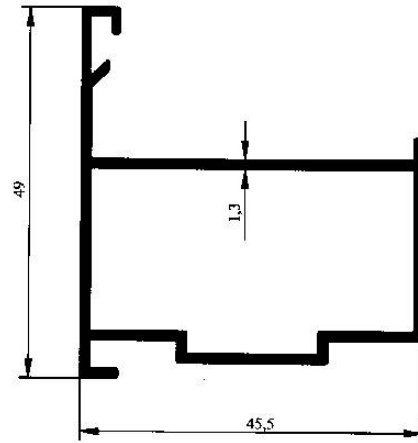

Profil No : 2030
 Gramaj : 0.628 kg/m
 Çevre : 225 mm

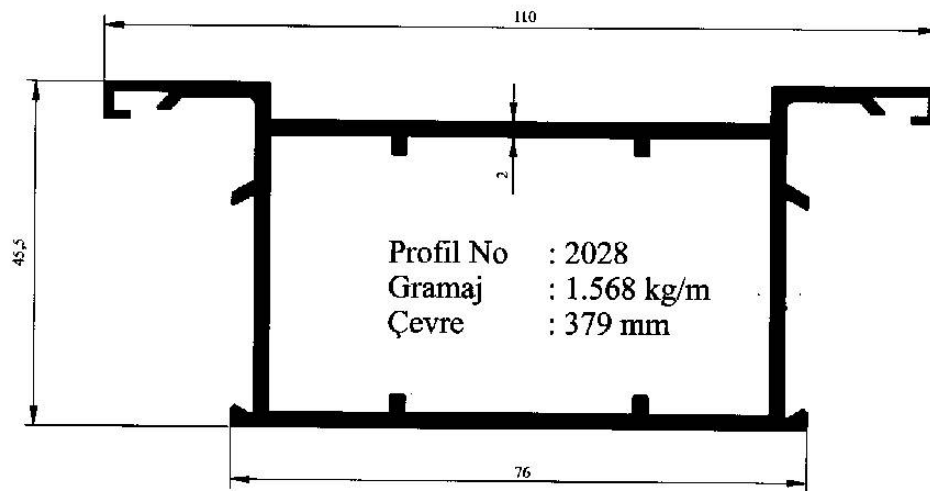

Profil No : 2028
 Gramaj : 1.568 kg/m
 Çevre : 379 mm

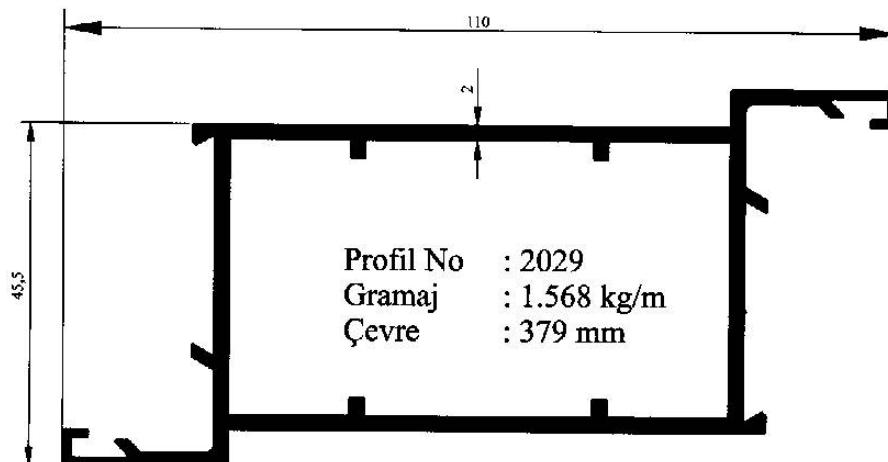

Profil No : 2029
 Gramaj : 1.568 kg/m
 Çevre : 379 mm

Hliníková okna a dveře
Windows And Doors Profiles

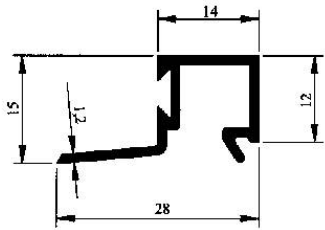

Profil No : 2031
Gramaj : 0.209 kg/m
Çevre : 127 mm

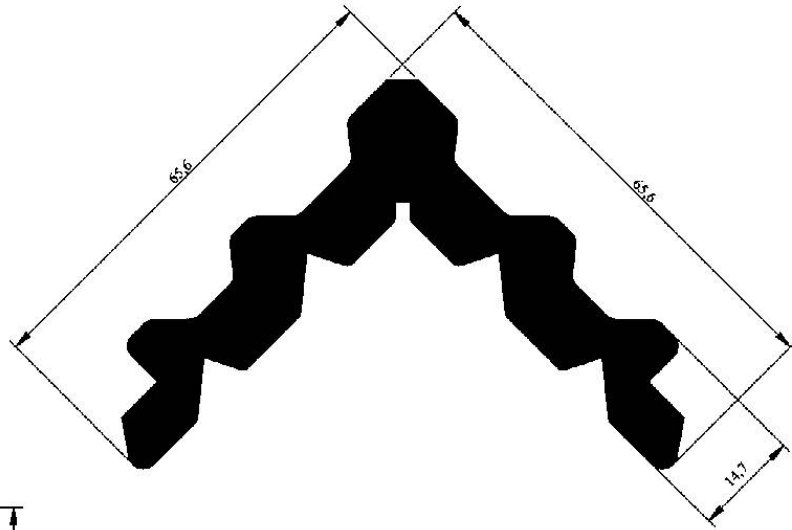

Profil No : 2032
Gramaj : 3.170 kg/m
Çevre : 292 mm

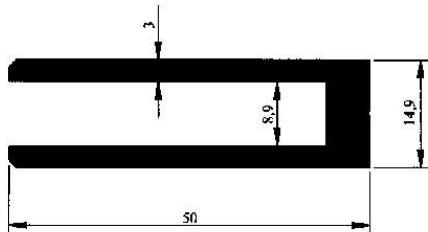

Profil No : 2033
Gramaj : 0.954 kg/m
Çevre : 217 mm

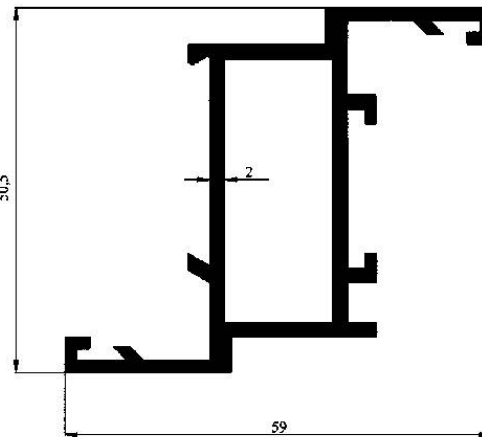

Profil No : 2034
Gramaj : 1.055 kg/m
Çevre : 295 mm

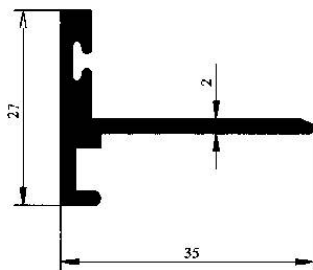

Profil No : 2035
Gramaj : 0.423 kg/m
Çevre : 139 mm

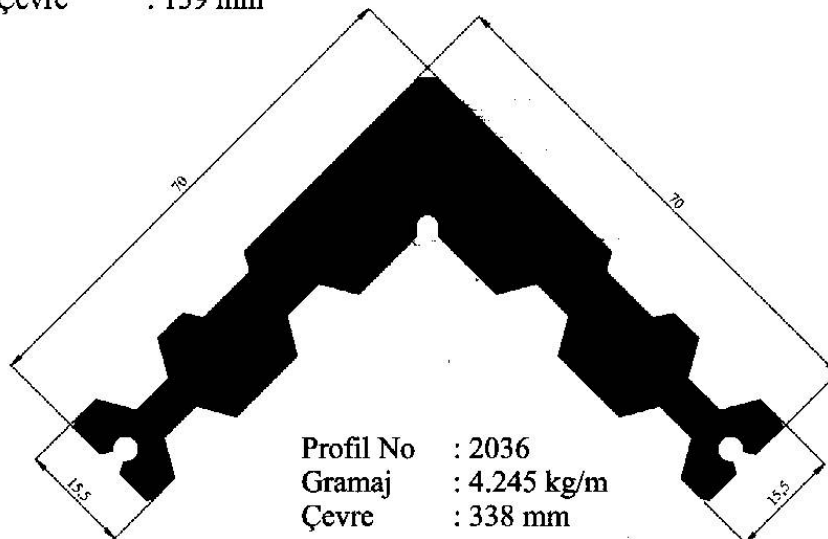

Profil No : 2036
Gramaj : 4.245 kg/m
Çevre : 338 mm

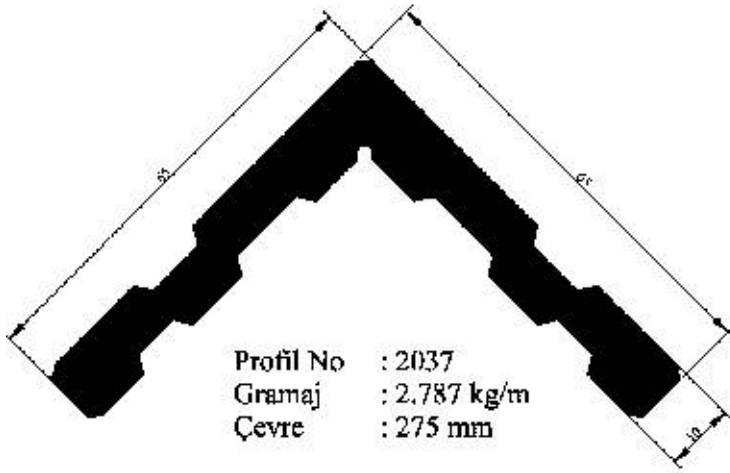

Profil No : 2037
Gramaj : 2.787 kg/m
Çevre : 275 mm

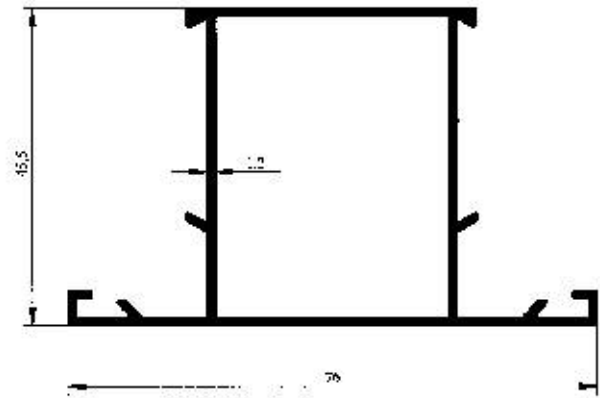

Profil No : 2038
Gramaj : 0.766 kg/m
Çevre : 304 mm

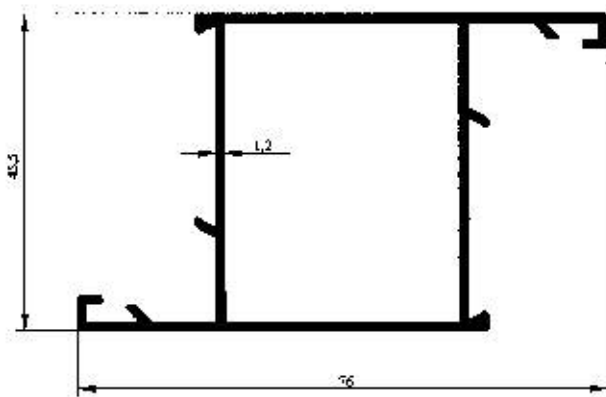

Profil No : 2039
Gramaj : 0.766 kg/m
Çevre : 304 mm

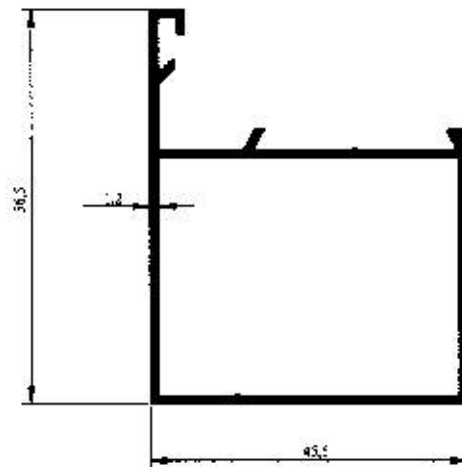

Profil No : 2040
Gramaj : 0.643 kg/m
Çevre : 234 mm

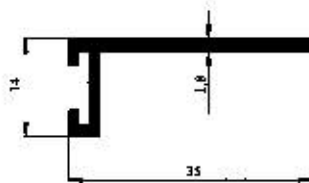

Profil No : 2042
Gramaj : 0.251 kg/m
Çevre : 112 mm

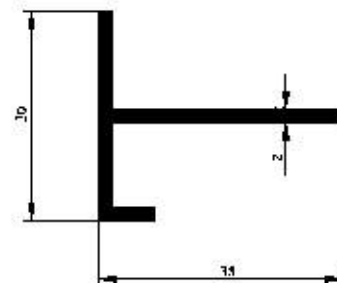

Profil No : 2041
Gramaj : 0.374 kg/m
Çevre : 142 mm

Hliníková okna a dveře
Windows And Doors Profiles

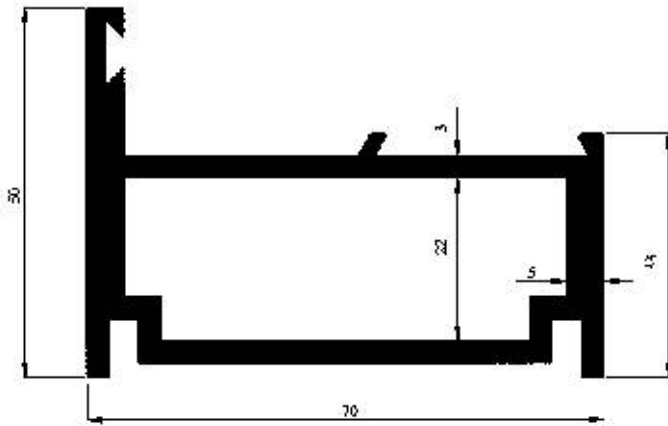

Profil No : 2043
Gramaj : 2.068 kg/m
Çevre : 293 mm

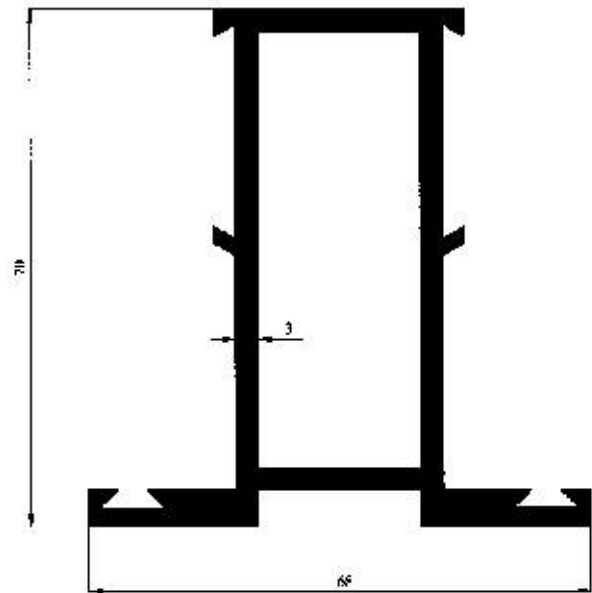

Profil No : 2044
Gramaj : 2.034 kg/m
Çevre : 340 mm

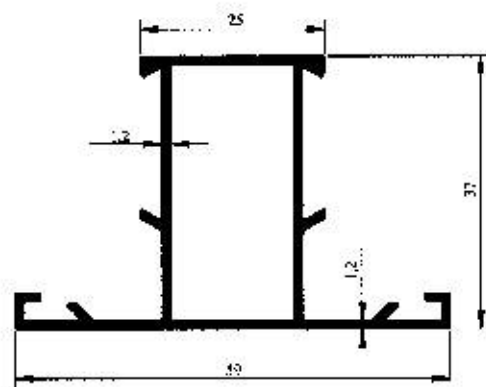

Profil No : 2045
Gramaj : 0.599 kg/m
Çevre : 252 mm

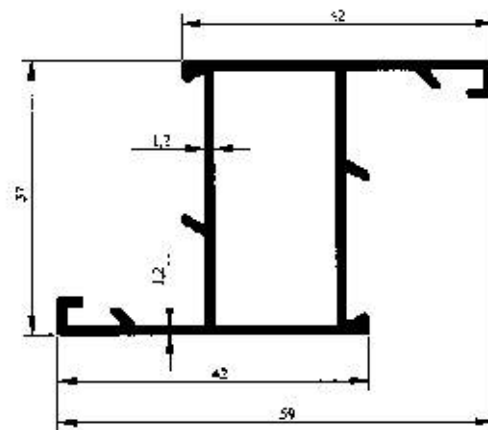

Profil No : 2046
Gramaj : 0.599 kg/m
Çevre : 252 mm

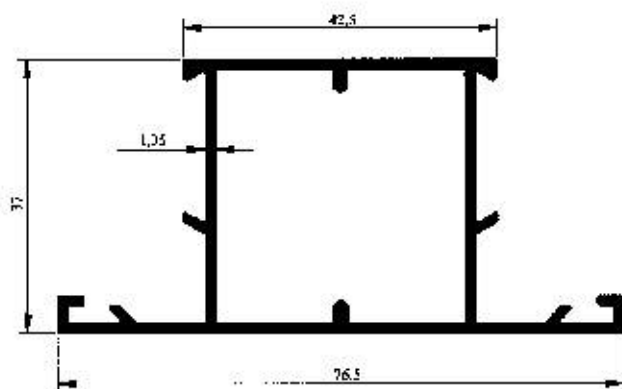

Profil No : 2048
Gramaj : 0.816 kg/m
Çevre : 285 mm

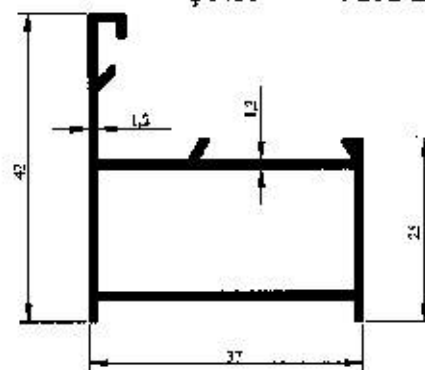

Profil No : 2047
Gramaj : 0.493 kg/m
Çevre : 194 mm



Hliníková okna a dveře
Windows And Doors Profiles

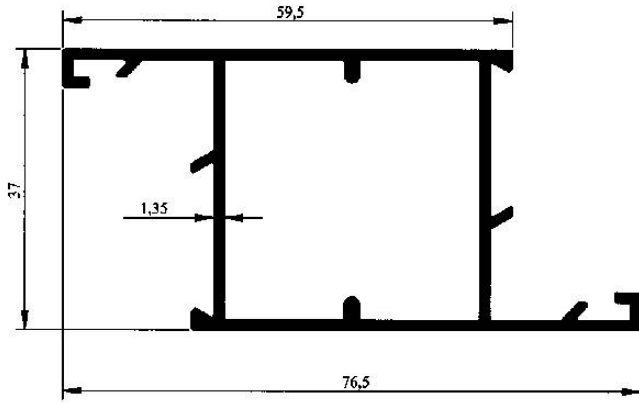

Profil No : 2049
 Gramaj : 0.816 kg/m
 Çevre : 285 mm

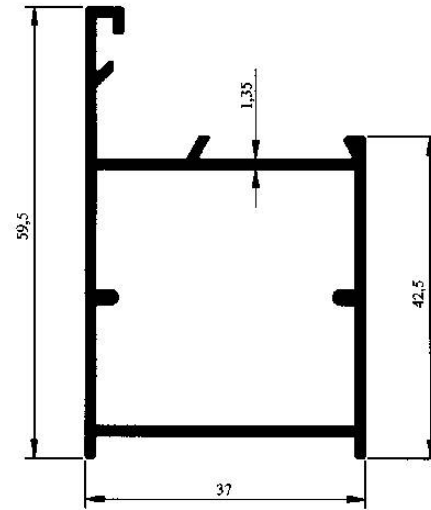

Profil No : 2050
 Gramaj : 0.705 kg/m
 Çevre : 228 mm

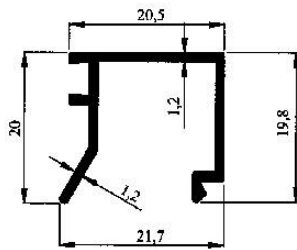

Profil No : 2051
 Gramaj : 0.209 kg/m
 Çevre : 131 mm

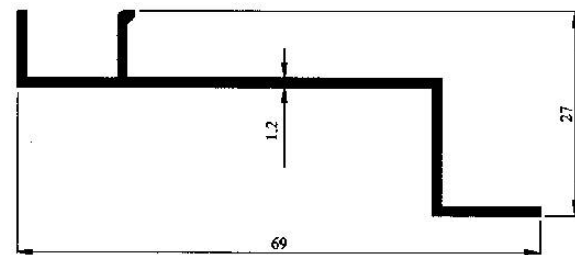

Profil No : 2053
 Gramaj : 0.339 kg/m
 Çevre : 211 mm

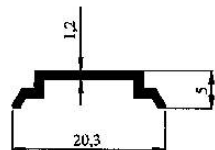

Profil No : 2052
 Gramaj : 0.084 kg/m
 Çevre : 55 mm

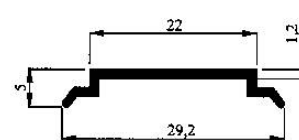

Profil No : 2054
 Gramaj : 0.112 kg/m
 Çevre : 72 mm

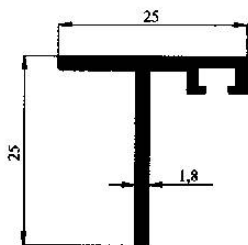

Profil No : 2055
 Gramaj : 0.262 kg/m
 Çevre : 117 mm

Hliníková okna a dveře
Windows And Doors Profiles

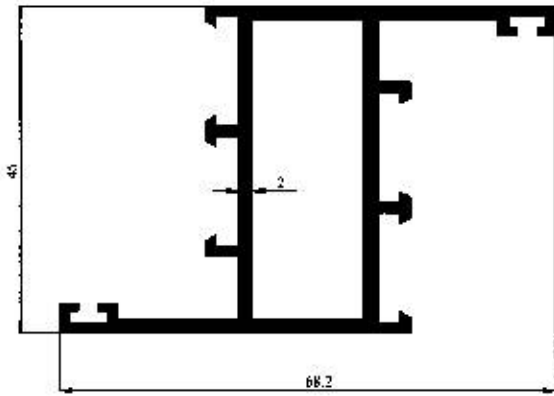

Profil No : 2056
Gramaj : 1,095 kg/m
Çevre : 326 mm

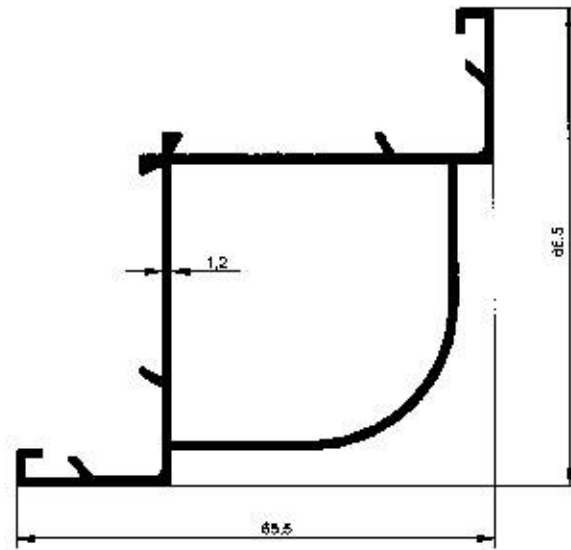

Profil No : 2058
Gramaj : 0,759 kg/m
Çevre : 315 mm

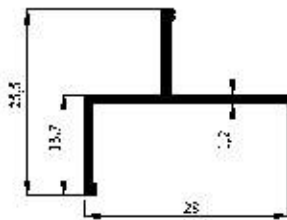

Profil No : 2059
Gramaj : 0,174 kg/m
Çevre : 109 mm

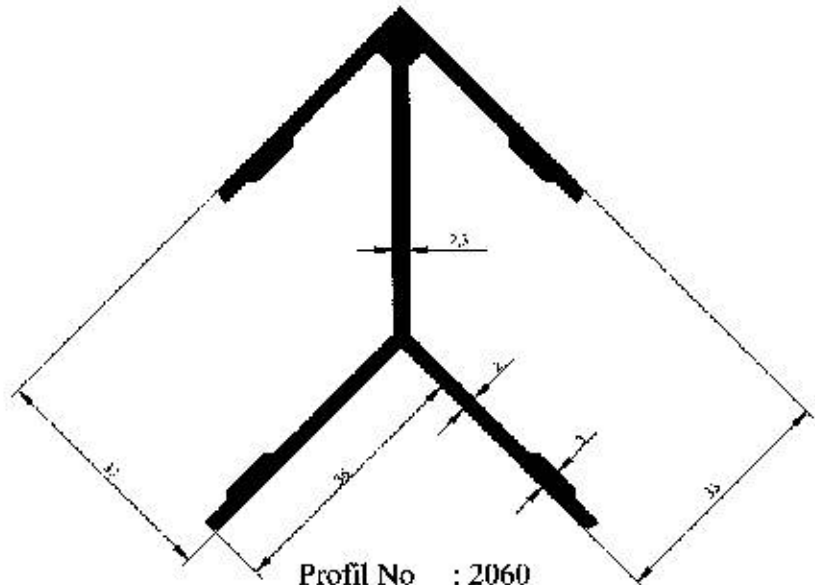

Profil No : 2060
Gramaj : 1,141 kg/m
Çevre : 364 mm

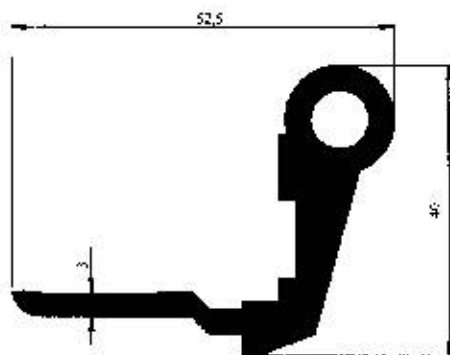

Profil No : 2066
Gramaj : 1,173 kg/m
Çevre : 175 mm

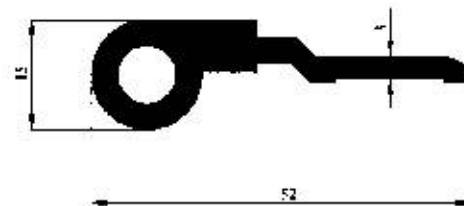

Profil No : 2065
Gramaj : 0,773 kg/m
Çevre : 126 mm

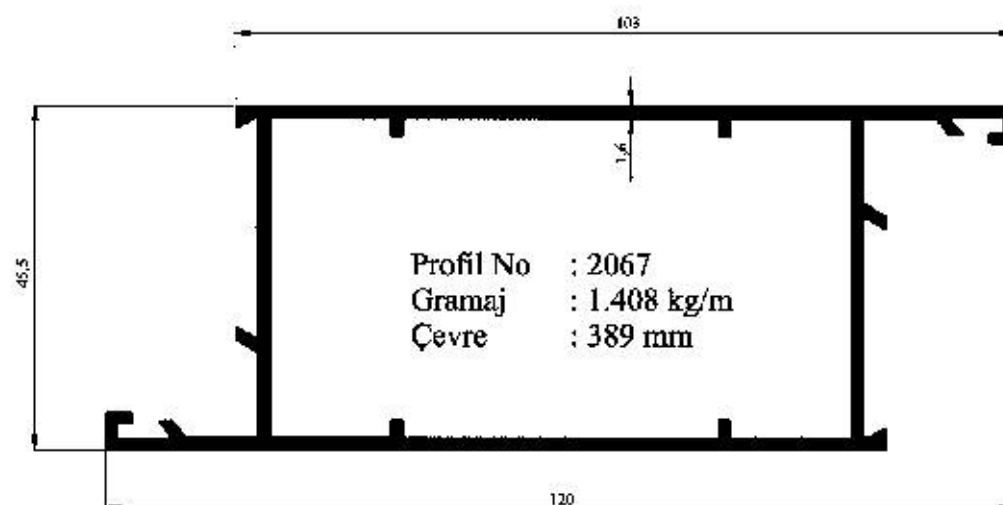
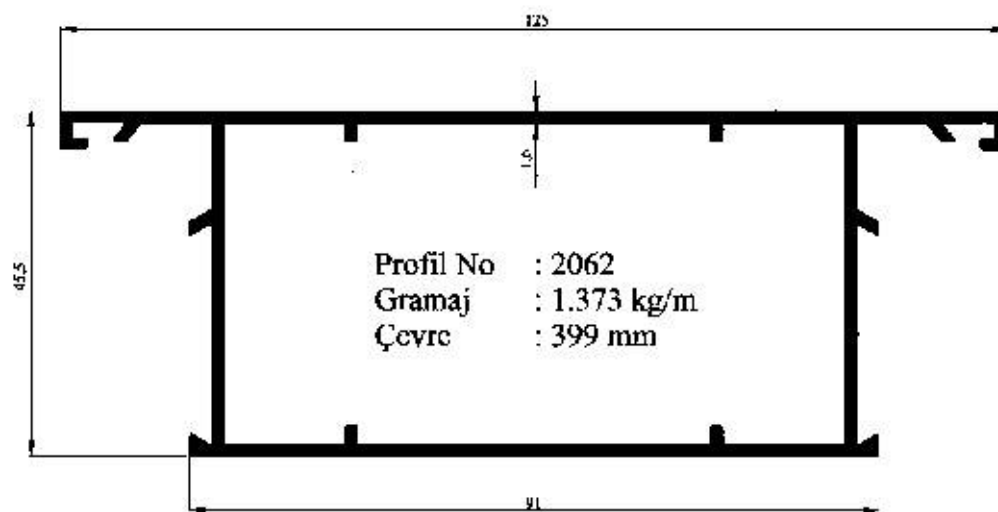
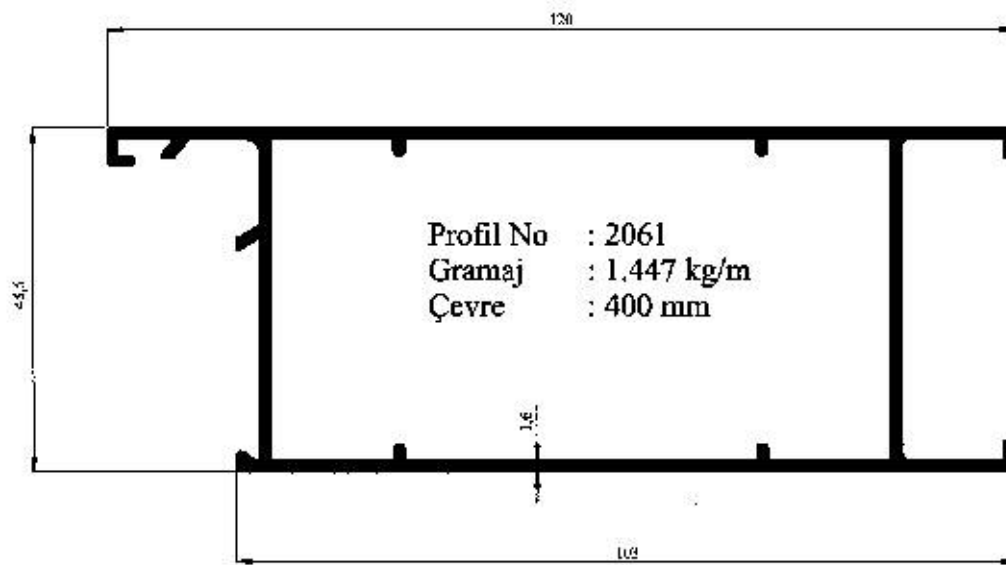

Hliníková okna a dveře
Windows And Doors Profiles

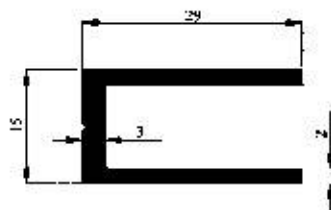

Profil No : 2068
Gramaj : 0.403 kg/m
Çevre : 140 mm

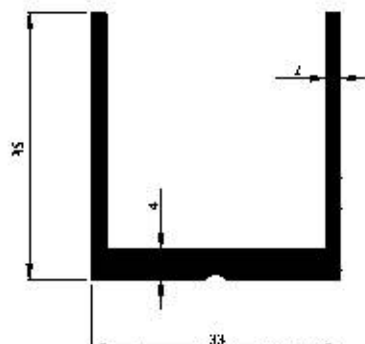

Profil No : 2069
Gramaj : 0.690 kg/m
Çevre : 199 mm

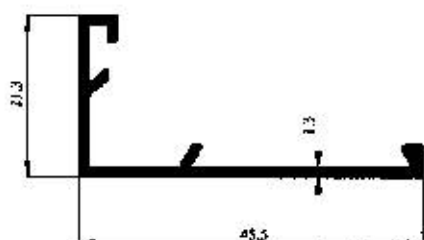

Profil No : 2070
Gramaj : 0.294 kg/m
Çevre : 165 mm

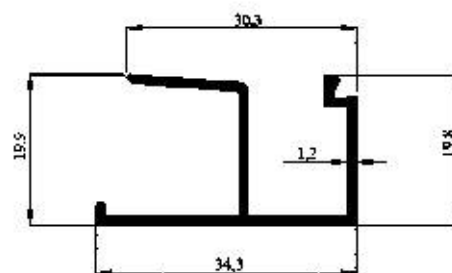

Profil No : 2073
Gramaj : 0.296 kg/m
Çevre : 182 mm

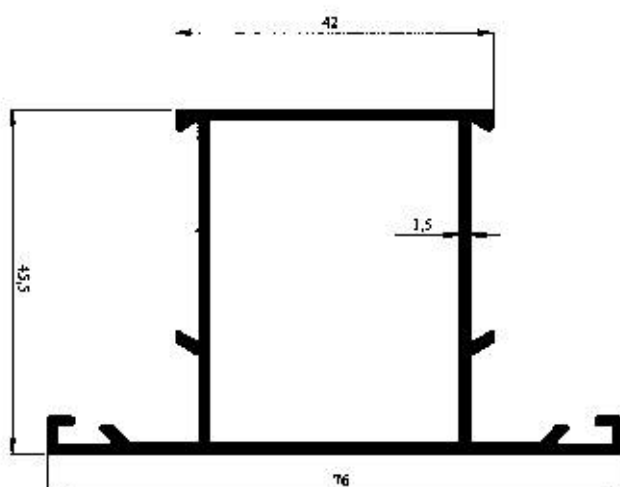

Profil No : 2074
Gramaj : 0.922 kg/m
Çevre : 302 mm

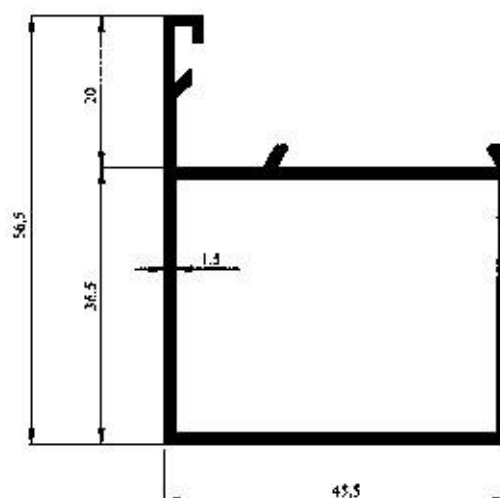

Profil No : 2075
Gramaj : 0.783 kg/m
Çevre : 235 mm

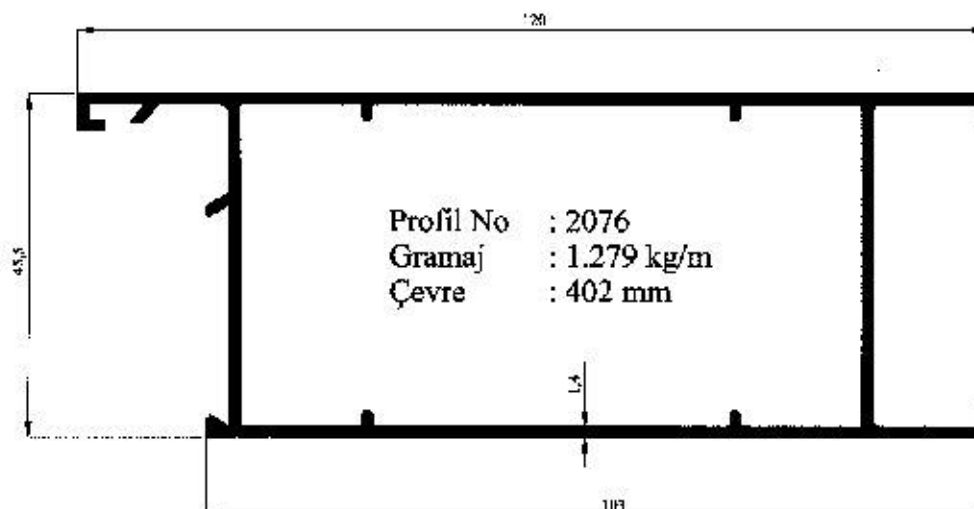
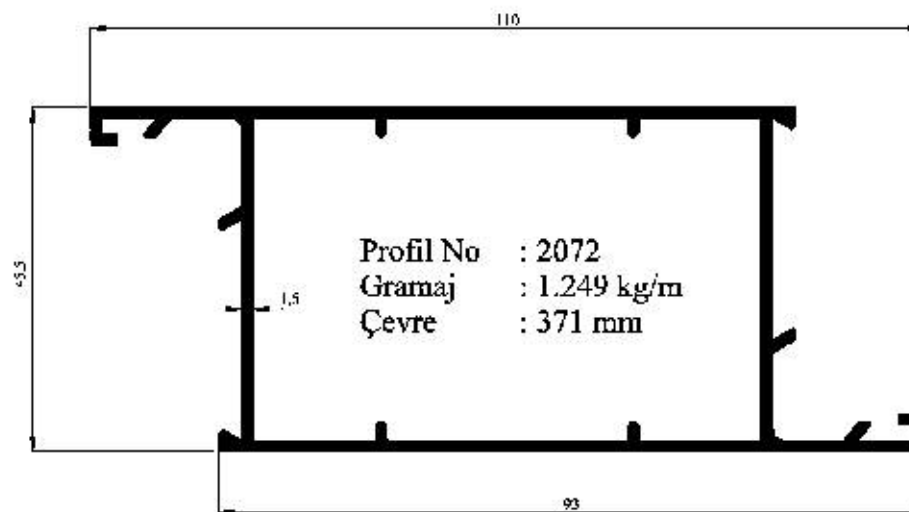
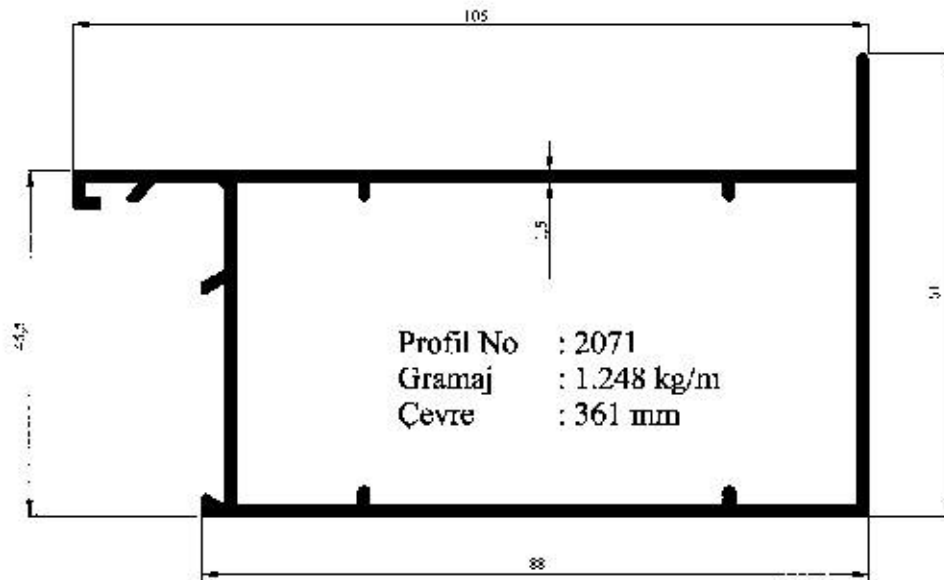

Hliníková okna a dveře
Windows And Doors Profiles

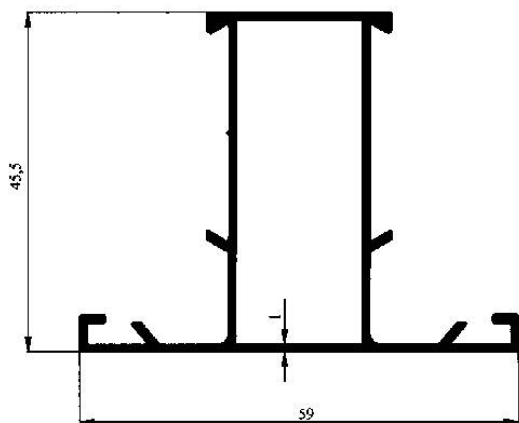

Profil No : 2078
Gramaj : 0.572 kg/m
Çevre : 273 mm

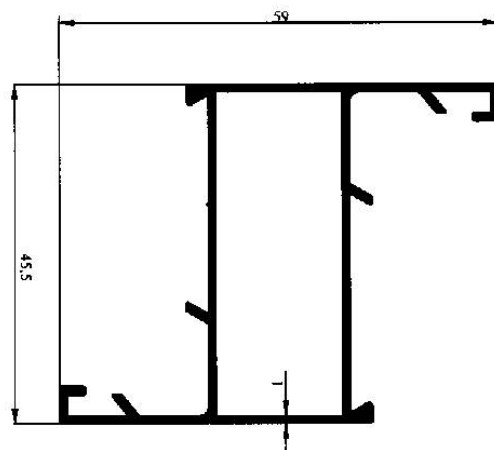

Profil No : 2079
Gramaj : 0.572 kg/m
Çevre : 273 mm

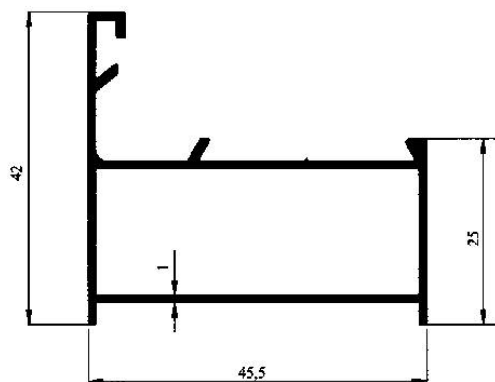

Profil No : 2080
Gramaj : 0.472 kg/m
Çevre : 228 mm

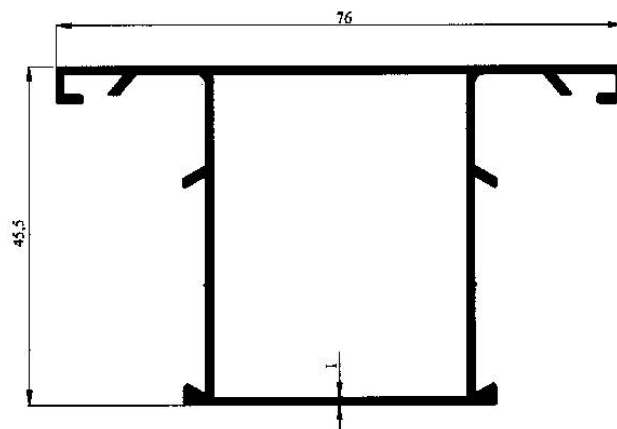

Profil No : 2081
Gramaj : 0.663 kg/m
Çevre : 307 mm

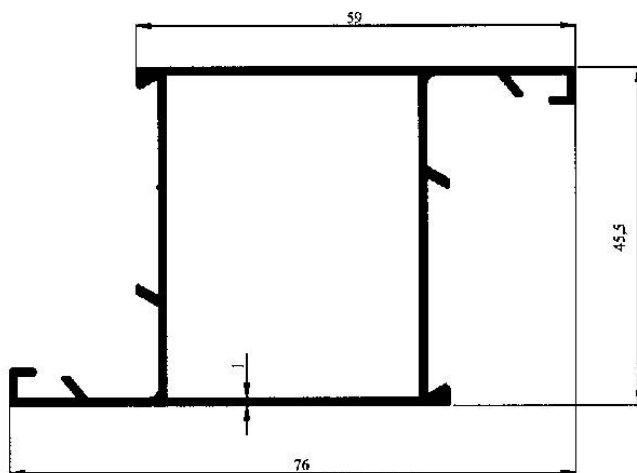

Profil No : 2082
Gramaj : 0.657 kg/m
Çevre : 307 mm

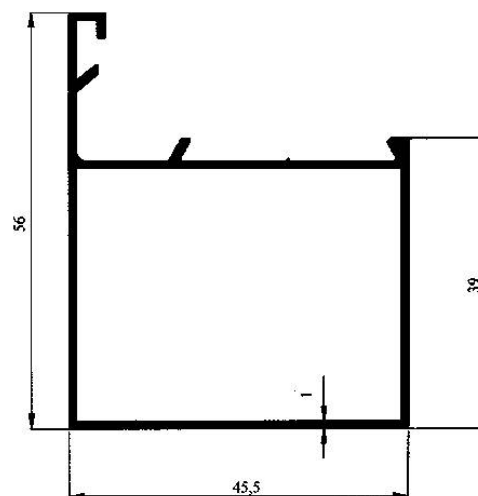

Profil No : 2083
Gramaj : 0.547 kg/m
Çevre : 235 mm

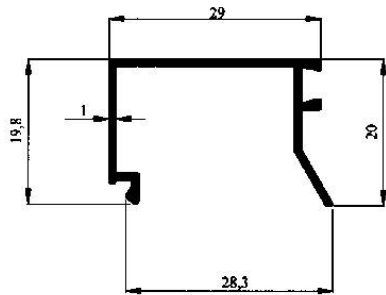

Profil No : 2084
Gramaj : 0.209 kg/m
Çevre : 151 mm

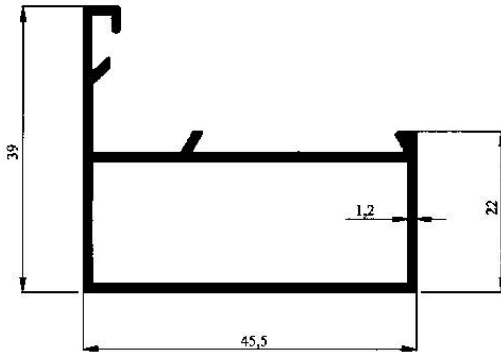

Profil No : 2086
Gramaj : 0.526 kg/m
Çevre : 200 mm

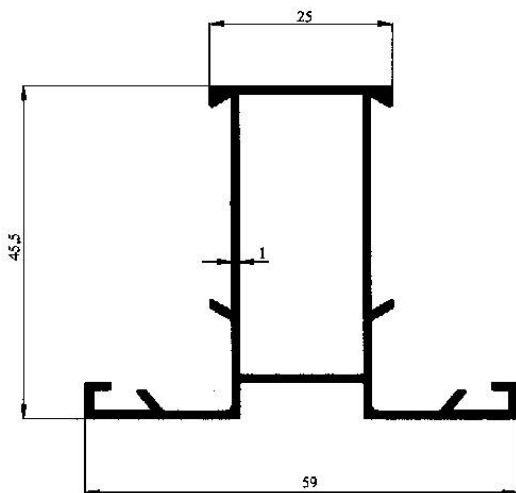

Profil No : 2101
Gramaj : 0.570 kg/m
Çevre : 283 mm

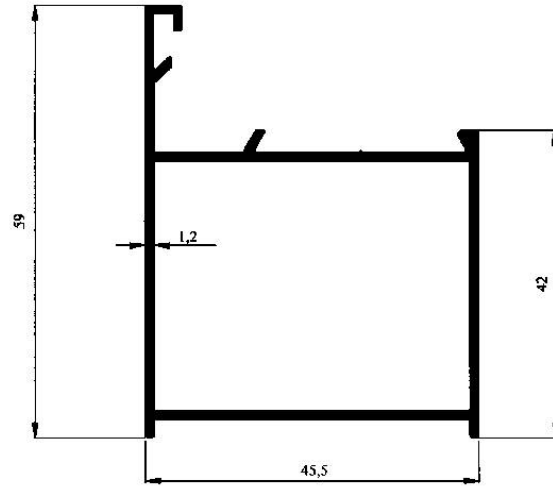

Profil No : 2085
Gramaj : 0.656 kg/m
Çevre : 245 mm

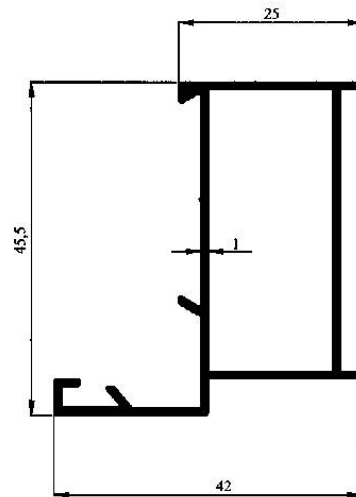

Profil No : 2100
Gramaj : 0.457 kg/m
Çevre : 213 mm

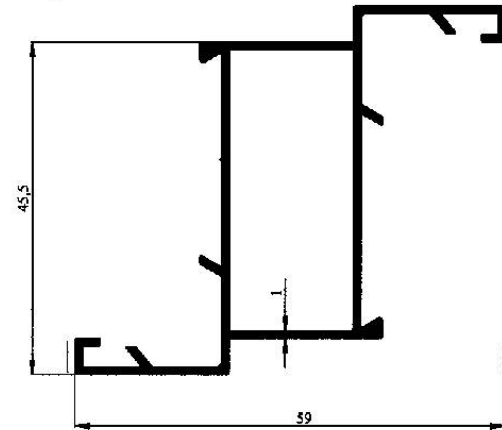

Profil No : 2102
Gramaj : 0.570 kg/m
Çevre : 283 mm

Hliníková okna a dveře
Windows And Doors Profiles

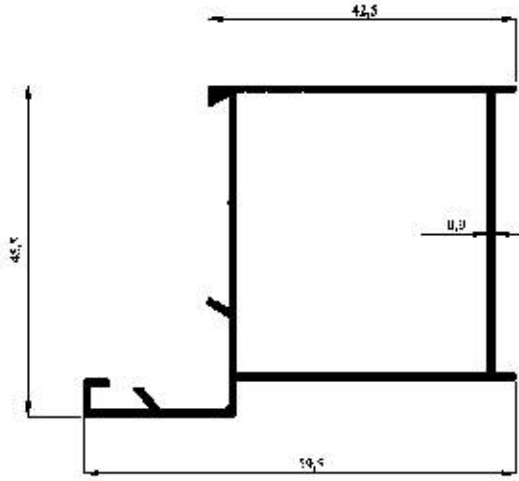

Profil No : 2103
Gramaj : 0.498 kg/m
Çevre : 249 mm

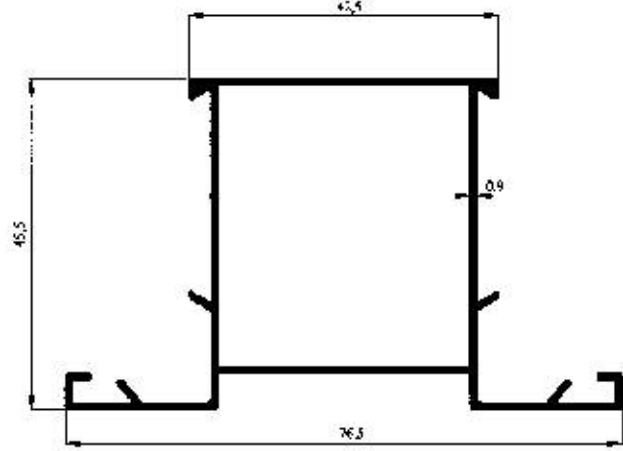

Profil No : 2104
Gramaj : 0.600 kg/m
Çevre : 320 mm

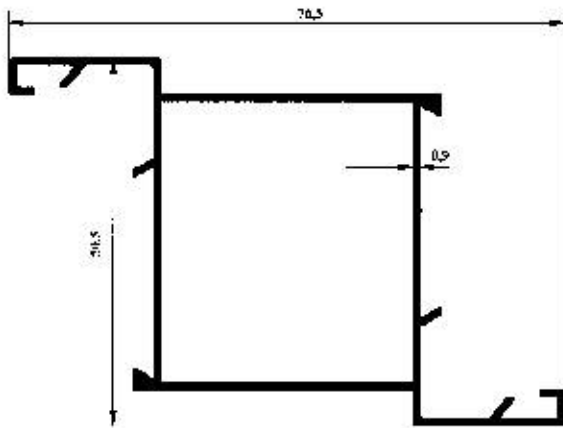

Profil No : 2105
Gramaj : 0.600 kg/m
Çevre : 320 mm

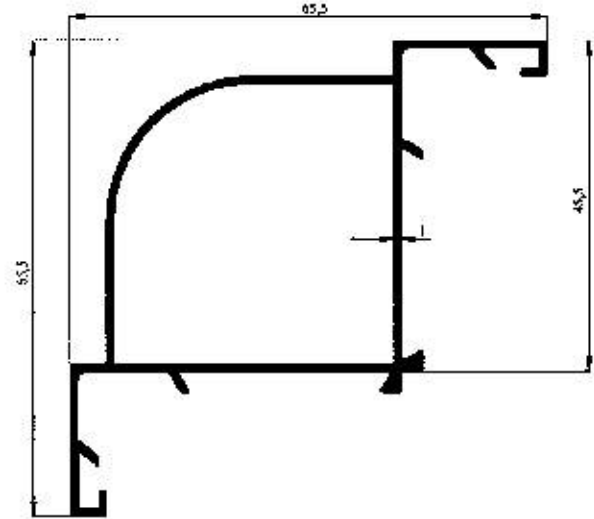

Profil No : 2106
Gramaj : 0.666 kg/m
Çevre : 316 mm

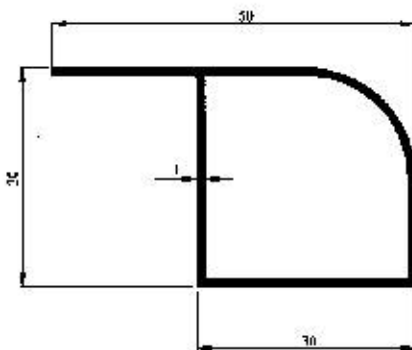

Profil No : 2109
Gramaj : 0.352 kg/m
Çevre : 153 mm

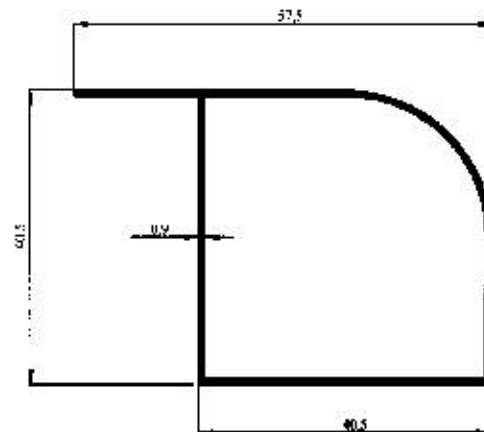

Profil No : 2110
Gramaj : 0.407 kg/m
Çevre : 187 mm



Hliníková okna a dveře Windows And Doors Profiles

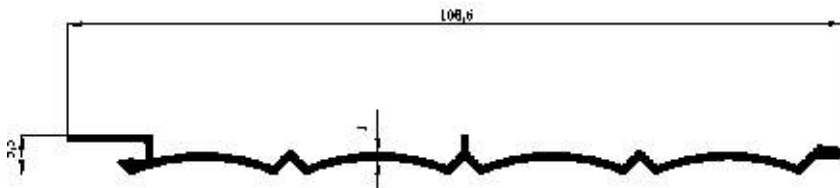

Profil No : 2111
Gramaj : 0.354 kg/m
Çevre : 253 mm

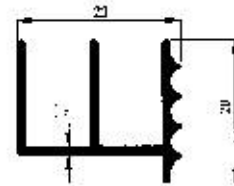

Profil No : 2112
Gramaj : 0.231 kg/m
Çevre : 146 mm

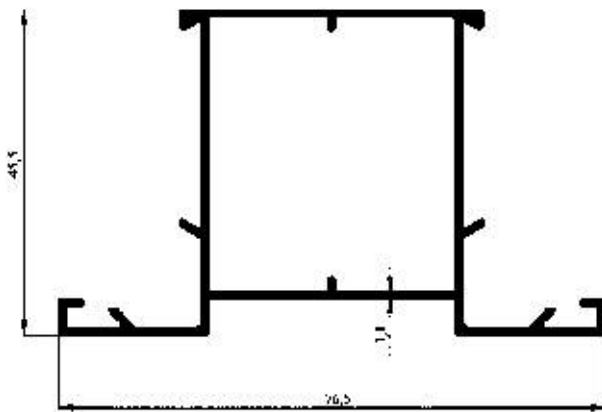

Profil No : 2113
Gramaj : 0.723 kg/m
Çevre : 315 mm

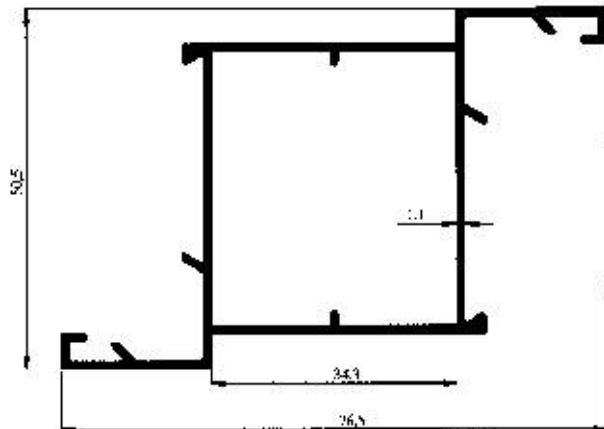

Profil No : 2114
Gramaj : 0.723 kg/m
Çevre : 315 mm

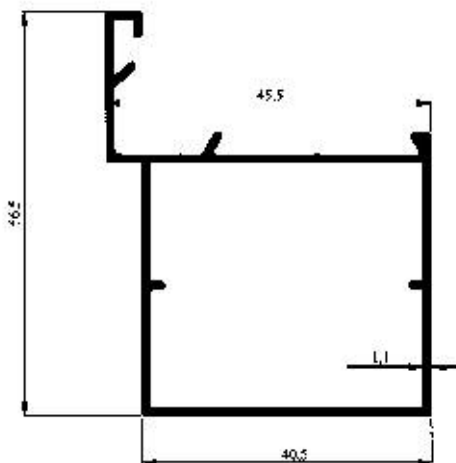

Profil No : 2115
Gramaj : 0.509 kg/m
Çevre : 236 mm

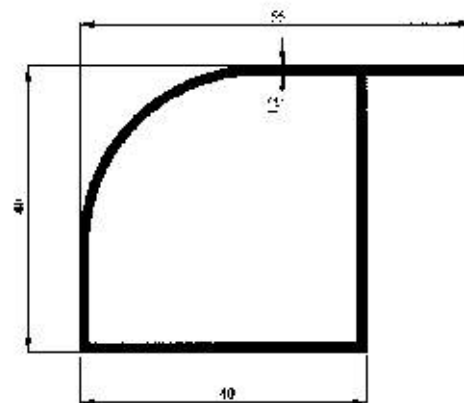

Profil No : 2116
Gramaj : 0.519 kg/m
Çevre : 179 mm

Hliníková okna a dveře
Windows And Doors Profiles

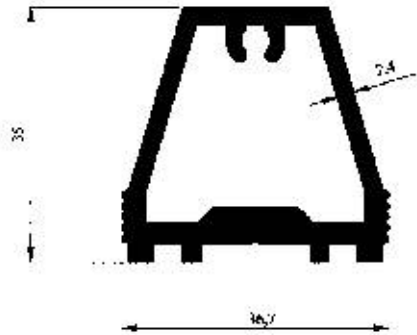

Profil No : 2117
Gramaj : 1.028 kg/m
Çevre : 148 mm

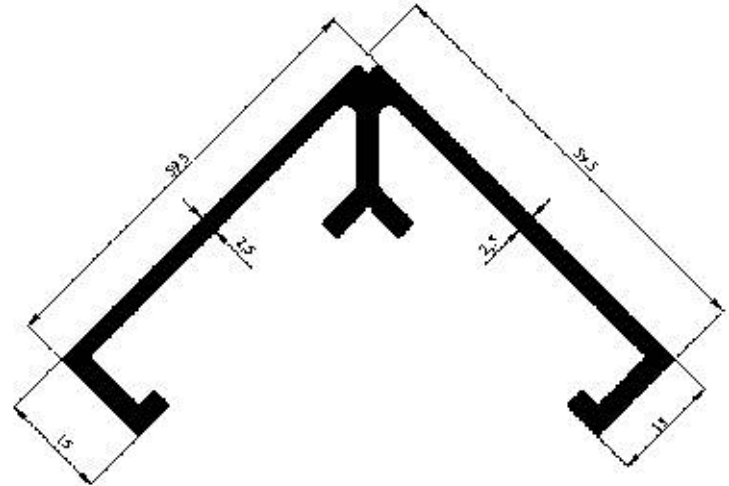

Profil No : 2118
Gramaj : 1.275 kg/m
Çevre : 346 mm

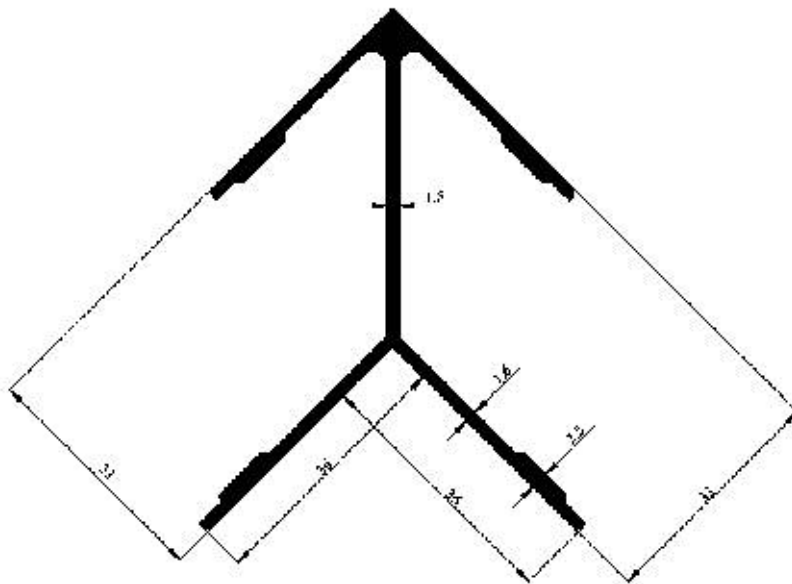

Profil No : 2119
Gramaj : 0.937 kg/m
Çevre : 364 mm

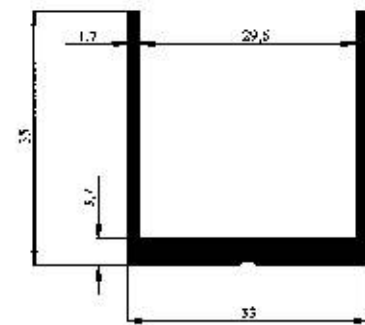

Profil No : 2120
Gramaj : 0.614 kg/m
Çevre : 199 mm

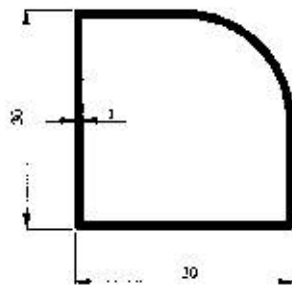

Profil No : 2121
Gramaj : 0.297 kg/m
Çevre : 113 mm

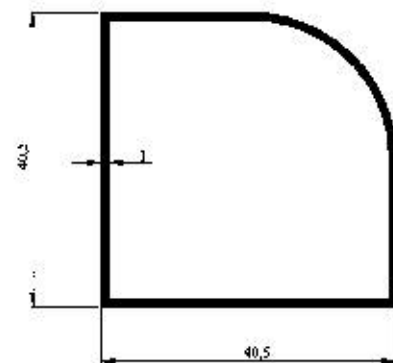

Profil No : 2122
Gramaj : 0.405 kg/m
Çevre : 153 mm

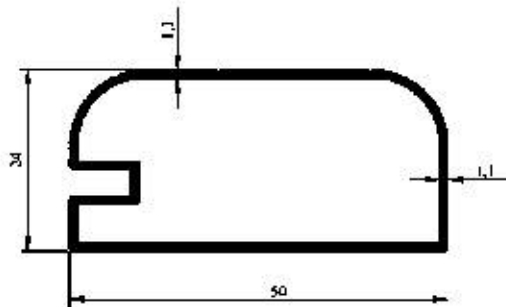

Profil No : 2123
Gramaj : 0.450 kg/m
Çevre : 156 mm

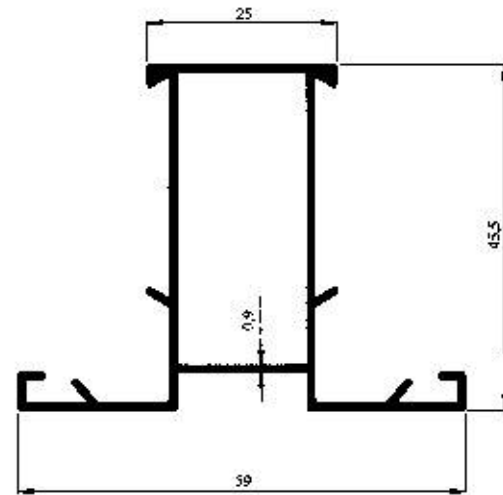

Profil No : 2124
Gramaj : 0.515 kg/m
Çevre : 285 mm

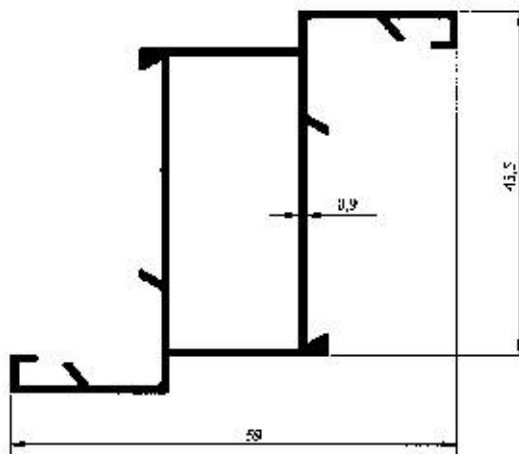

Profil No : 2125
Gramaj : 0.515 kg/m
Çevre : 285 mm

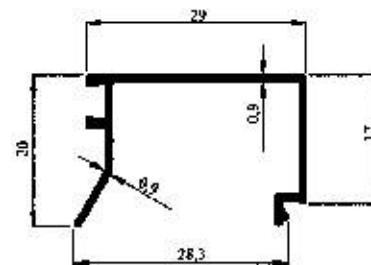

Profil No : 2126
Gramaj : 0.192 kg/m
Çevre : 151 mm

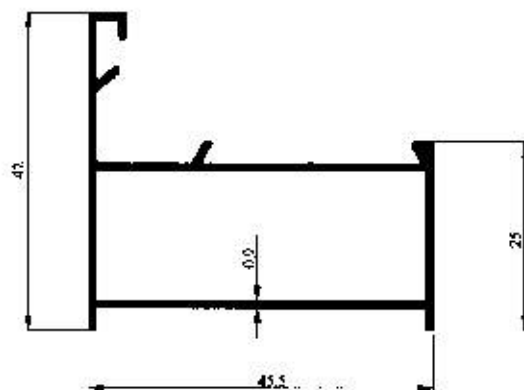

Profil No : 2127
Gramaj : 0.429 kg/m
Çevre : 213 mm

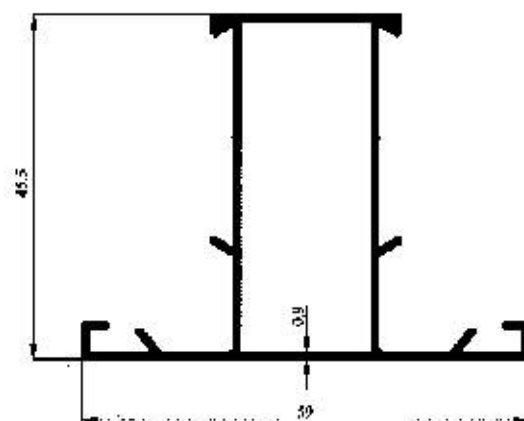

Profil No : 2128
Gramaj : 0.522 kg/m
Çevre : 273 mm

Hliníková okna a dveře
Windows And Doors Profiles

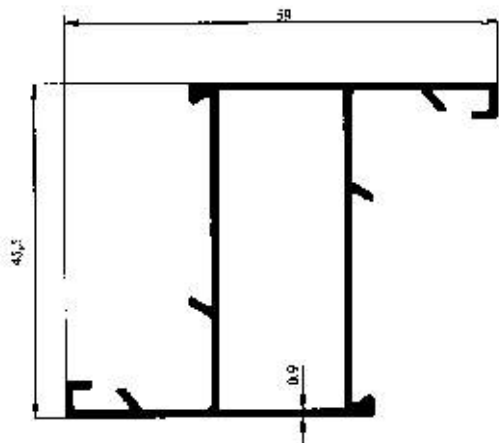

Profil No : 2129
Gramaj : 0.522 kg/m
Çevre : 274 mm

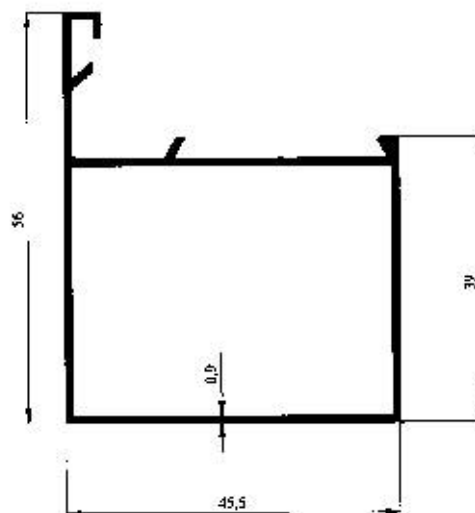

Profil No : 2130
Gramaj : 0.497 kg/m
Çevre : 235 mm

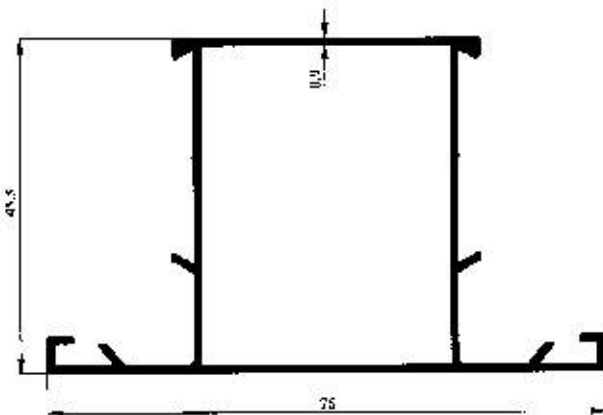

Profil No : 2131
Gramaj : 0.605 kg/m
Çevre : 308 mm

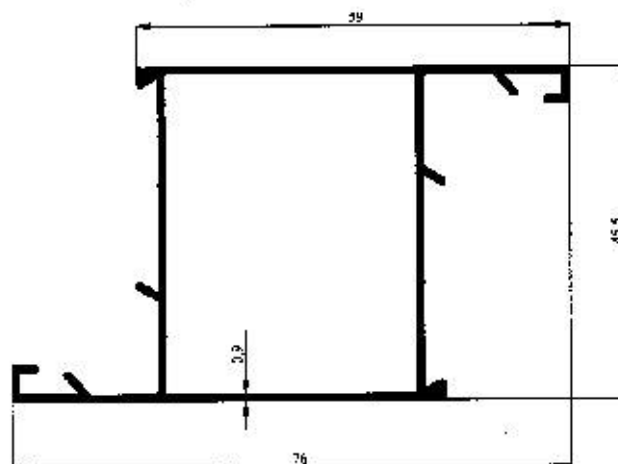

Profil No : 2132
Gramaj : 0.605 kg/m
Çevre : 308 mm

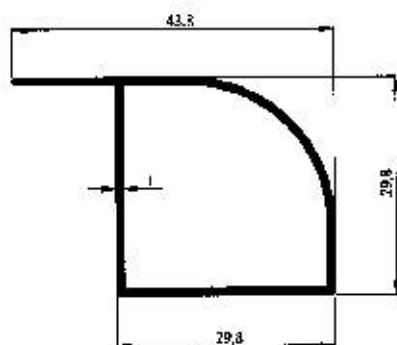

Profil No : 2133
Gramaj : 0.327 kg/m
Çevre : 139 mm

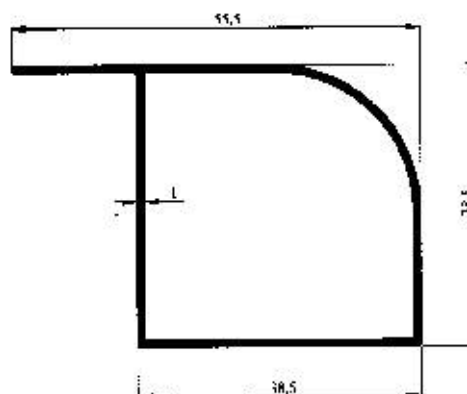

Profil No : 2134
Gramaj : 0.430 kg/m
Çevre : 179 mm

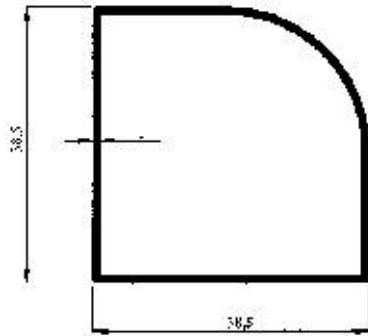

Profil No : 2135
Gramaj : 0.384 kg/m
Çevre : 145 mm

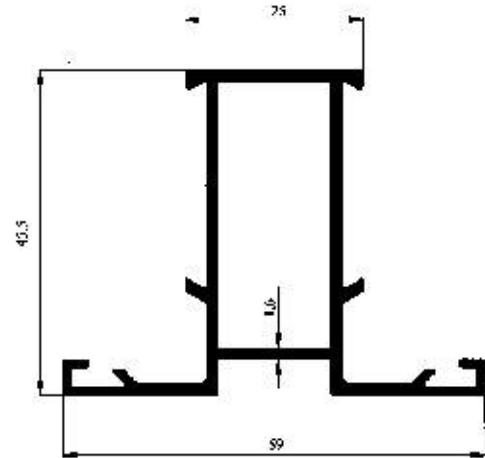

Profil No : 2150
Gramaj : 0.812 kg/m
Çevre : 278 mm

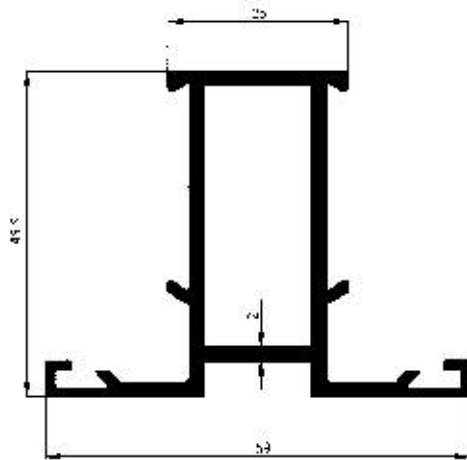

Profil No : 2151
Gramaj : 0.963 kg/m
Çevre : 278 mm

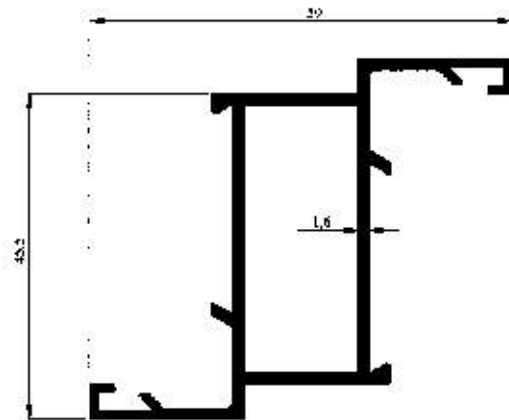

Profil No : 2152
Gramaj : 0.812 kg/m
Çevre : 278 mm

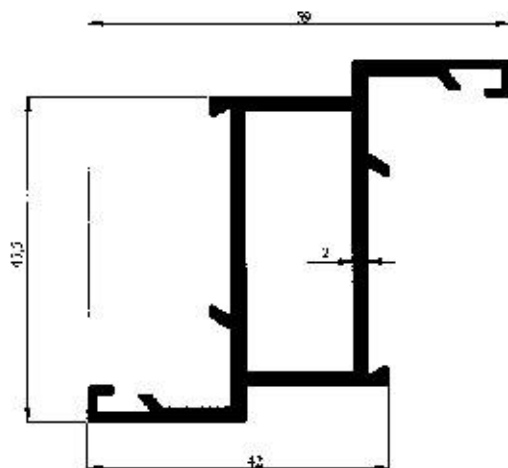

Profil No : 2153
Gramaj : 0.963 kg/m
Çevre : 278 mm

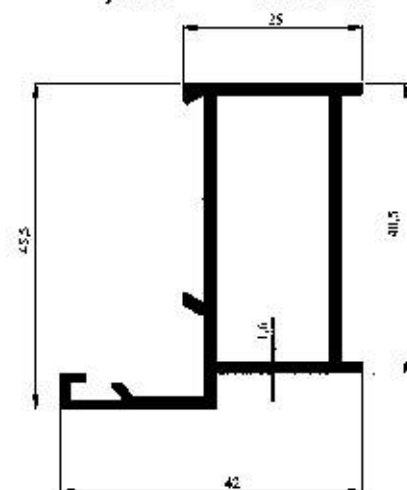

Profil No : 2154
Gramaj : 0.676 kg/m
Çevre : 210 mm

Hliníková okna a dveře
Windows And Doors Profiles

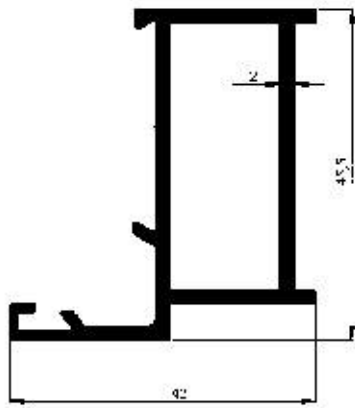

Profil No : 2155
Gramaj : 0.815 kg/m
Çevre : 210 mm

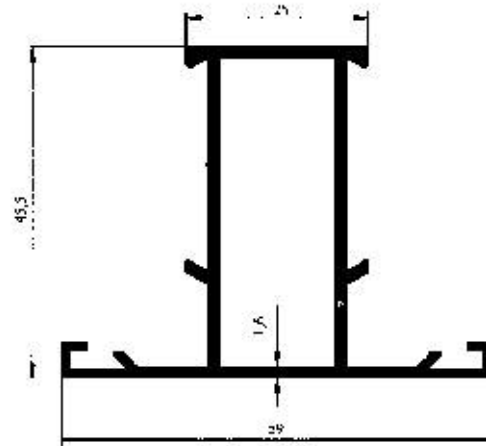

Profil No : 2156
Gramaj : 0.811 kg/m
Çevre : 269 mm

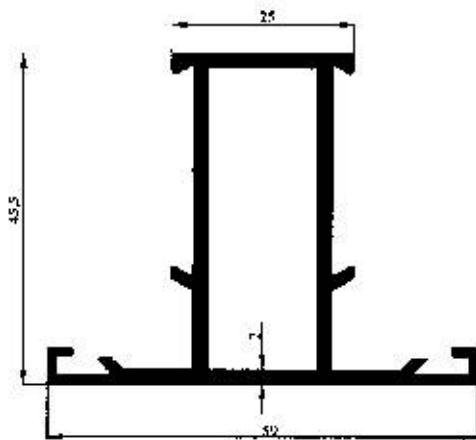

Profil No : 2157
Gramaj : 0.960 kg/m
Çevre : 268 mm

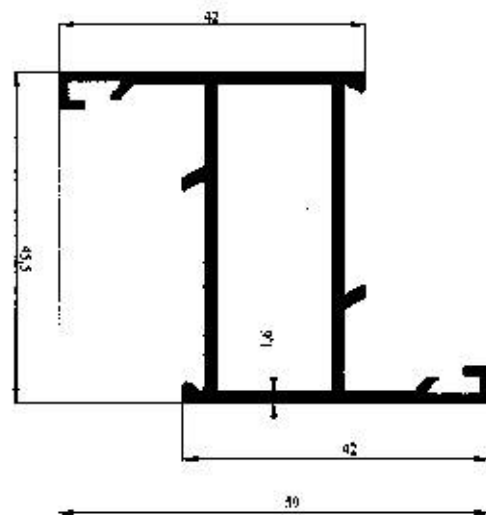

Profil No : 2158
Gramaj : 0.811 kg/m
Çevre : 269 mm

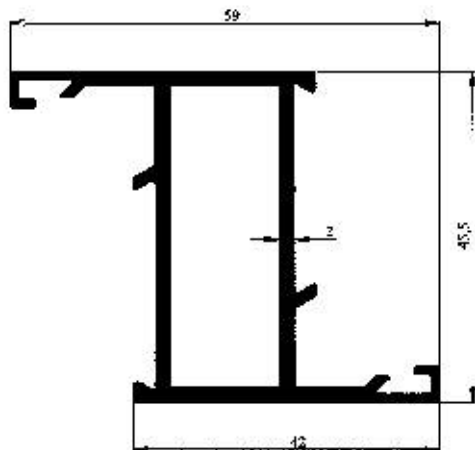

Profil No : 2159
Gramaj : 0.960 kg/m
Çevre : 268 mm

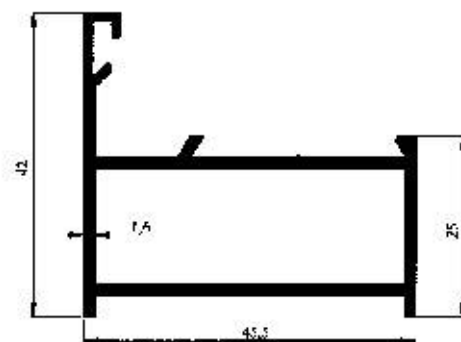

Profil No : 2160
Gramaj : 0.697 kg/m
Çevre : 211 mm



Hliníková okna a dveře
Windows And Doors Profiles

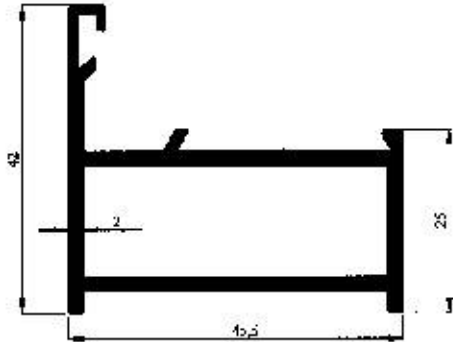

Profil No : 2161
Gramaj : 0.840 kg/m
Çevre : 210 mm

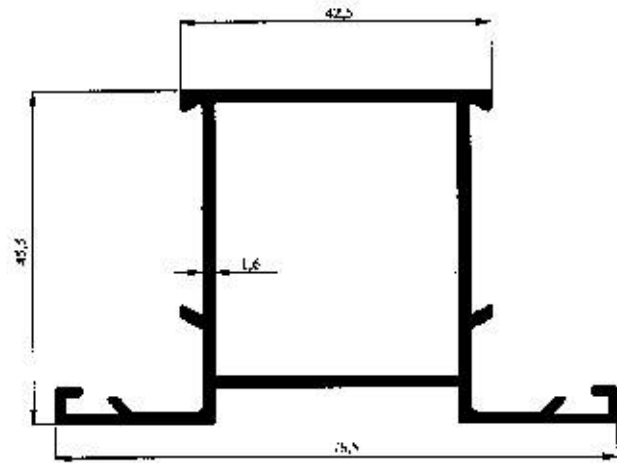

Profil No : 2162
Gramaj : 0.964 kg/m
Çevre : 313 mm

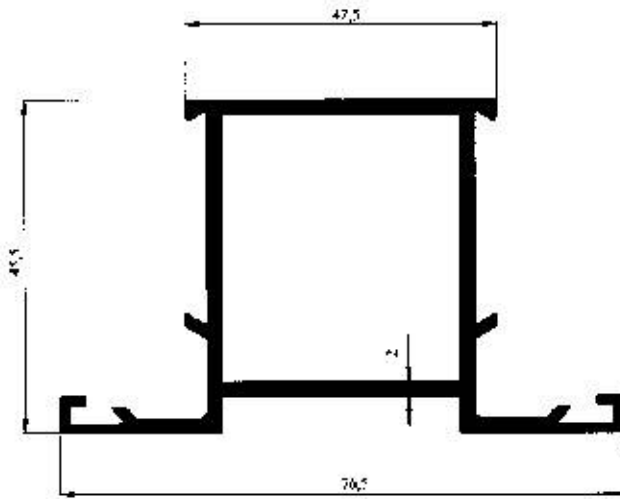

Profil No : 2163
Gramaj : 1.151 kg/m
Çevre : 312 mm

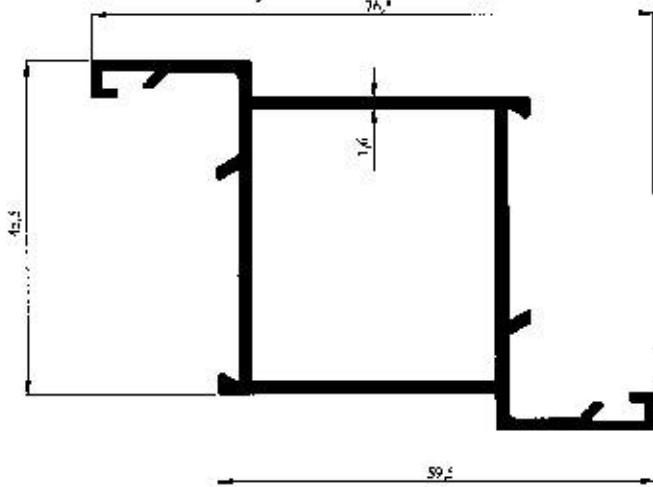

Profil No : 2164
Gramaj : 0.964 kg/m
Çevre : 313 mm

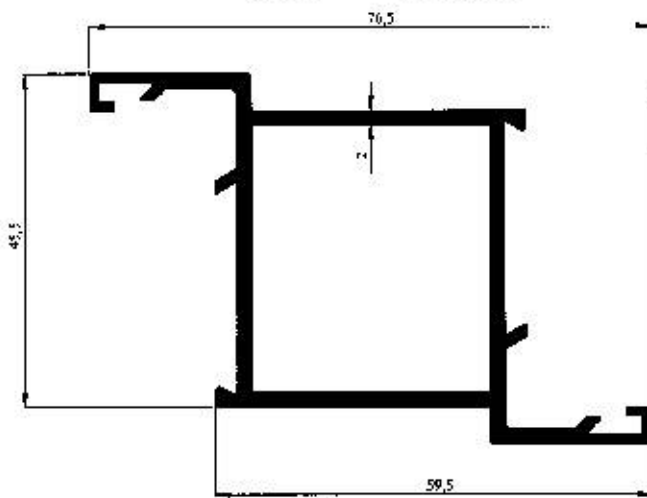

Profil No : 2165
Gramaj : 1.151 kg/m
Çevre : 312 mm

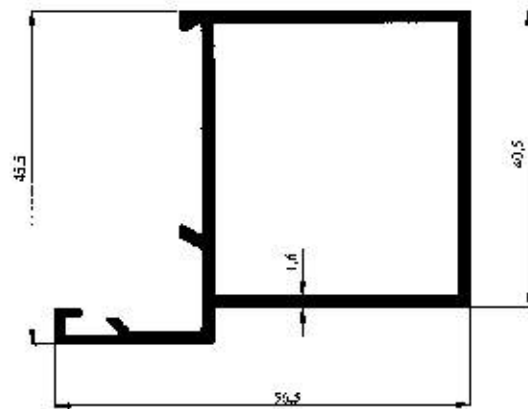

Profil No : 2166
Gramaj : 0.800 kg/m
Çevre : 233 mm

Hliníková okna a dveře
Windows And Doors Profiles

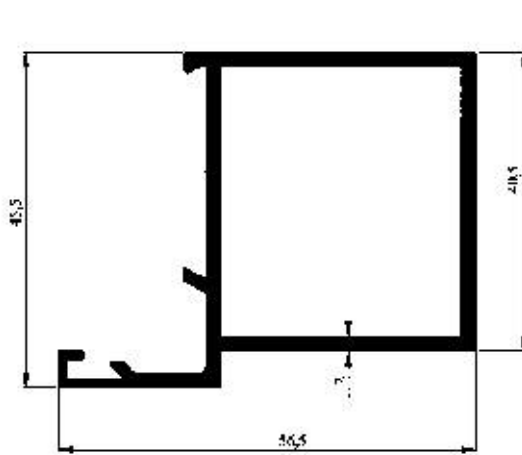

Profil No : 2167
Gramaj : 0.971 kg/m
Çevre : 233 mm

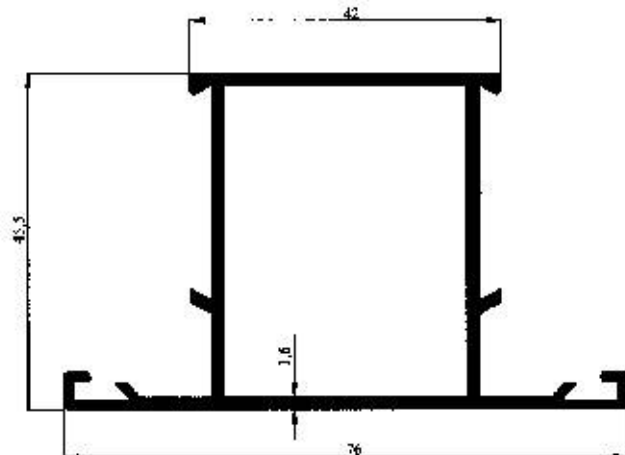

Profil No : 2168
Gramaj : 0.958 kg/m
Çevre : 203 mm

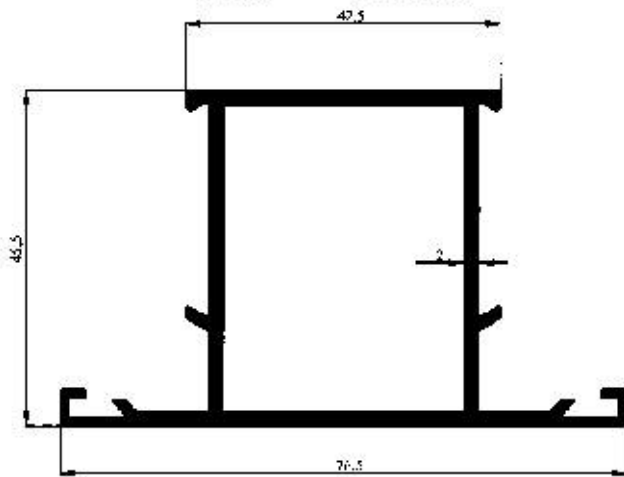

Profil No : 2169
Gramaj : 1.150 kg/m
Çevre : 303 mm

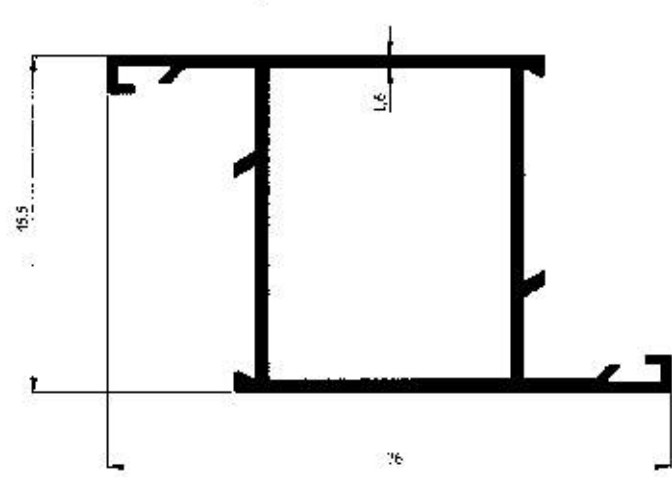

Profil No : 2170
Gramaj : 0.958 kg/m
Çevre : 303 mm

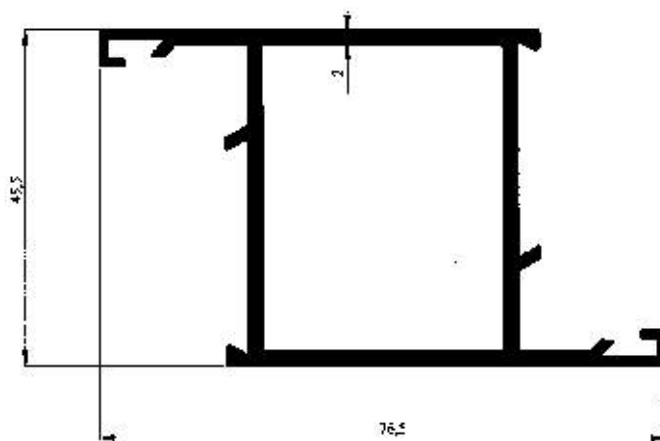

Profil No : 2171
Gramaj : 1.150 kg/m
Çevre : 303 mm

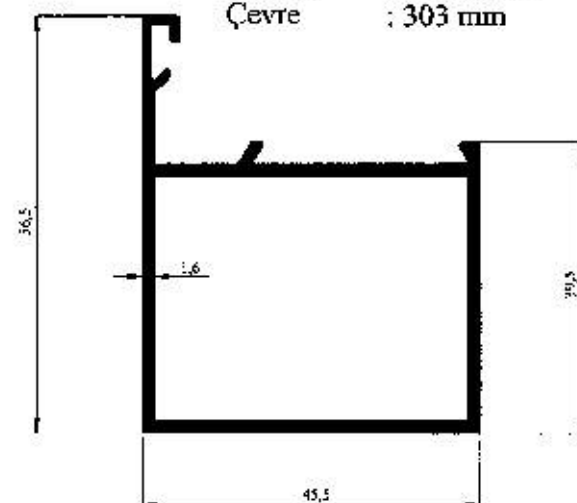

Profil No : 2172
Gramaj : 0.823 kg/m
Çevre : 234 mm

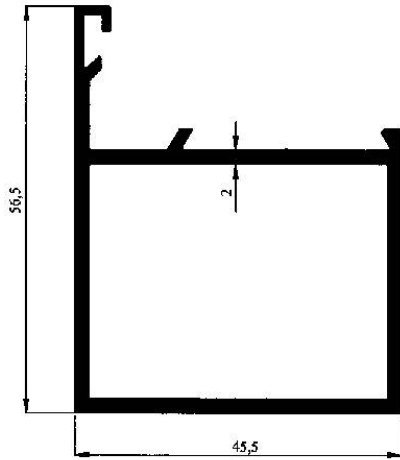

Profil No : 2173
Gramaj : 0.998 kg/m
Çevre : 233 mm

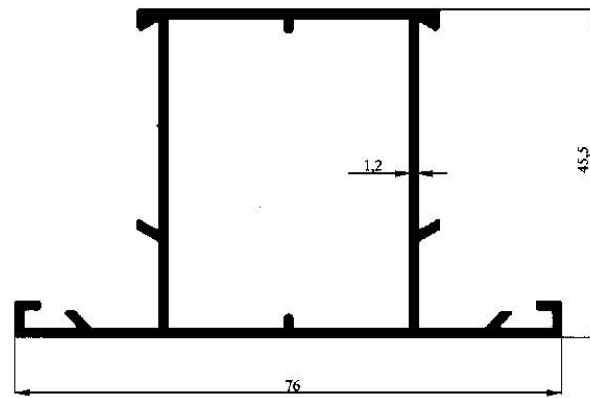

Profil No : 2174
Gramaj : 0.778 kg/m
Çevre : 304 mm

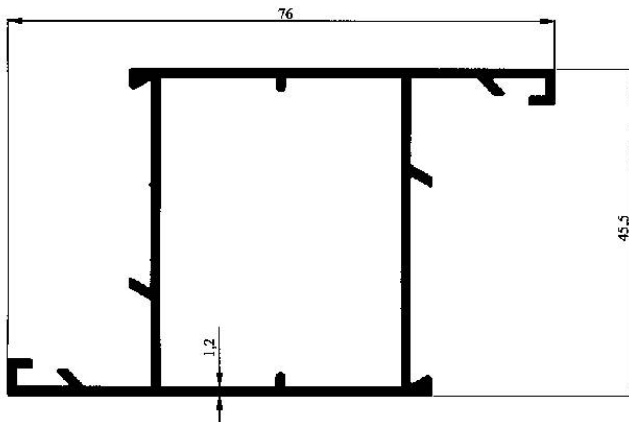

Profil No : 2175
Gramaj : 0.778 kg/m
Çevre : 304 mm

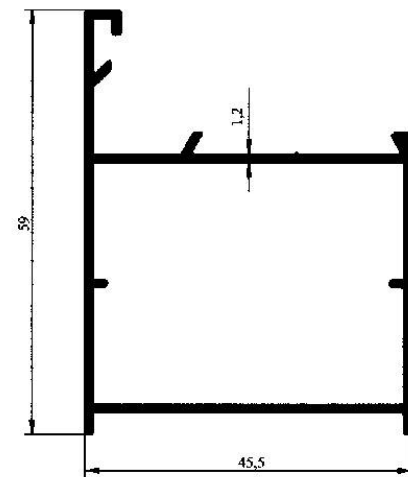

Profil No : 2176
Gramaj : 0.672 kg/m
Çevre : 245 mm

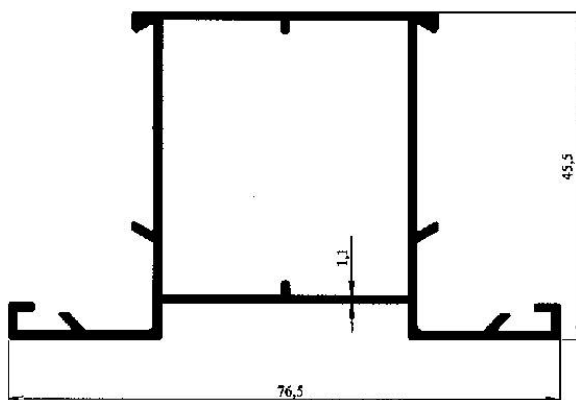

Profil No : 2177
Gramaj : 0.723 kg/m
Çevre : 315 mm

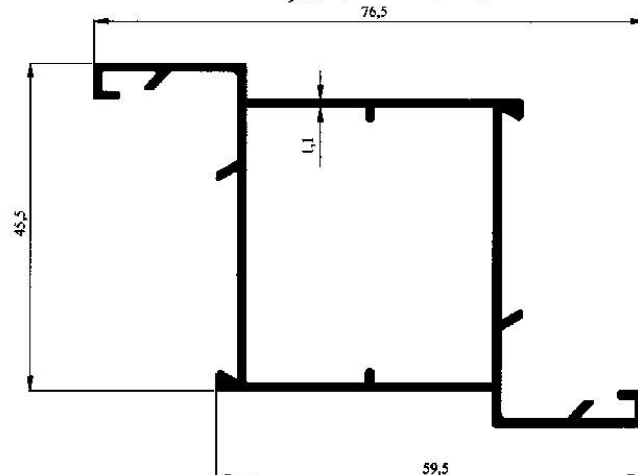

Profil No : 2178
Gramaj : 0.723 kg/m
Çevre : 315 mm

Hliníková okna a dveře
Windows And Doors Profiles

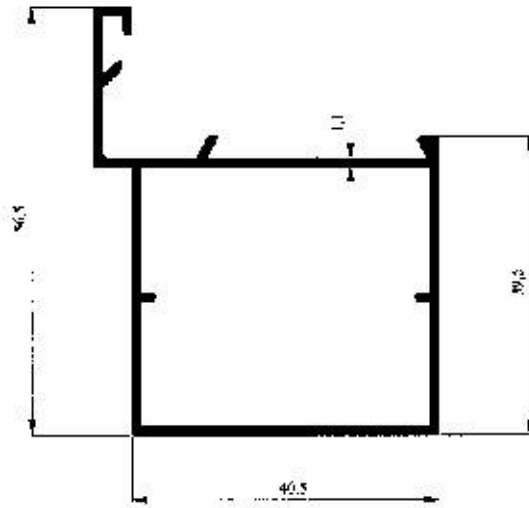

Profil No : 2179
Gramaj : 0.590 kg/m
Çevre : 234 mm

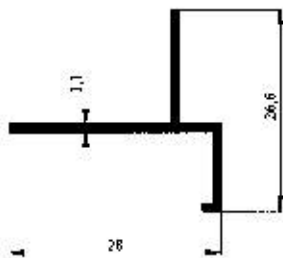

Profil No : 2500
Gramaj : 0.164 kg/m
Çevre : 112 mm

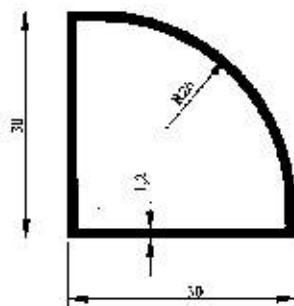

Profil No : 2792
Gramaj : 0.339 kg/m
Çevre : 109 mm

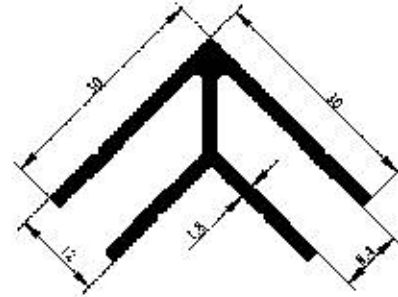

Profil No : 2278
Gramaj : 0.542 kg/m
Çevre : 214 mm

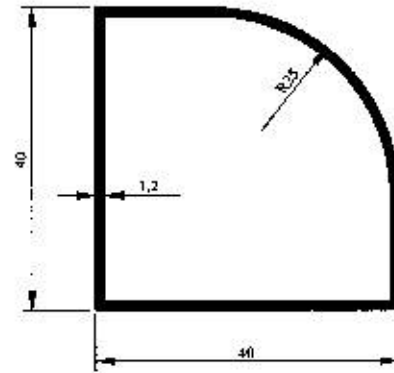

Profil No : 2791
Gramaj : 0.471 kg/m
Çevre : 149 mm

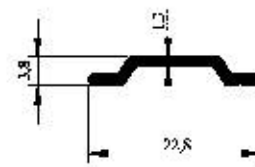

Profil No : 3011
Gramaj : 0.095 kg/m
Çevre : 52 mm

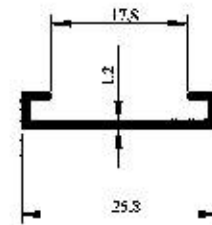

Profil No : 3012
Gramaj : 0.125 kg/m
Çevre : 79 mm

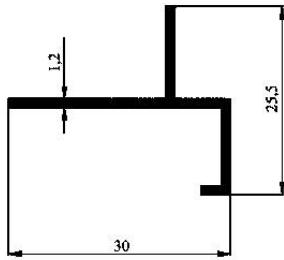

Profil No : 3013
Gramaj : 0.186 kg/m
Çevre : 117 mm

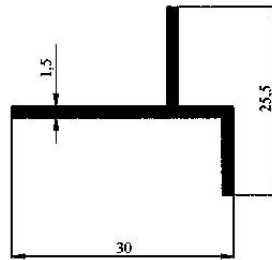

Profil No : 3014
Gramaj : 0.220 kg/m
Çevre : 111 mm

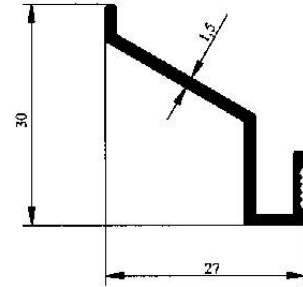

Profil No : 3016
Gramaj : 0.218 kg/m
Çevre : 116 mm

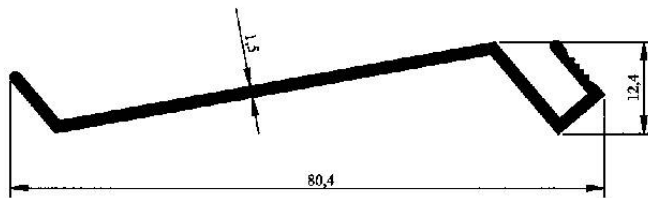

Profil No : 3017
Gramaj : 0.398 kg/m
Çevre : 201 mm

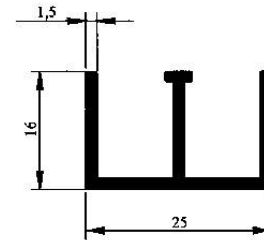

Profil No : 3022
Gramaj : 0.287 kg/m
Çevre : 143 mm

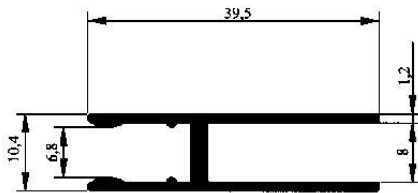

Profil No : 3024
Gramaj : 0.318 kg/m
Çevre : 174 mm

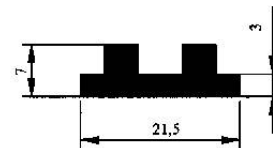

Profil No : 3041
Gramaj : 0.272 kg/m
Çevre : 65 mm

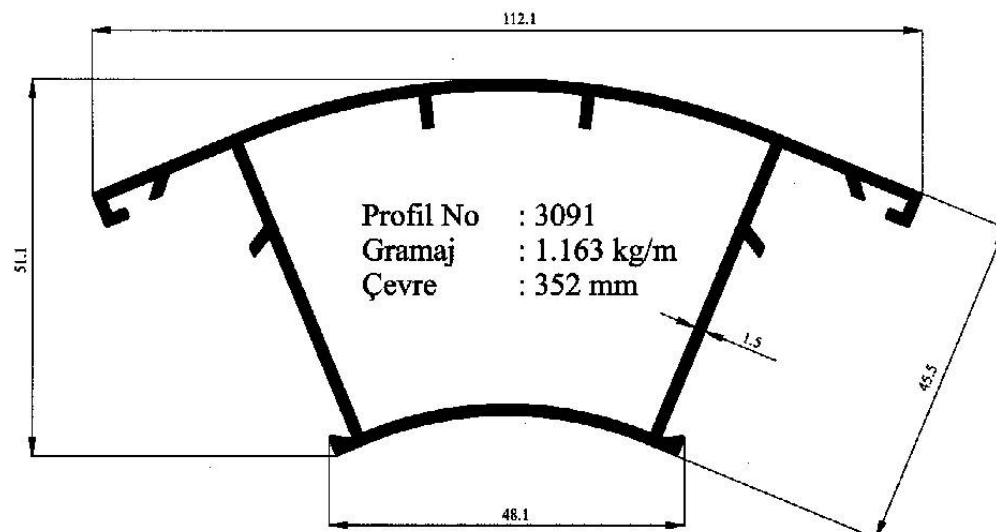

Profil No : 3091
Gramaj : 1.163 kg/m
Çevre : 352 mm

Hliníková okna a dveře
Windows And Doors Profiles

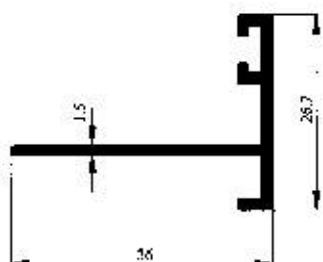

Profil No : 3079
Gramaj : 0.298 kg/m
Çevre : 148 mm

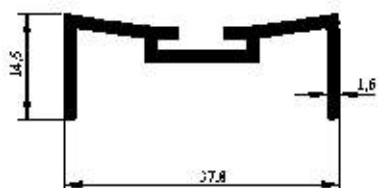

Profil No : 3133
Gramaj : 0.333 kg/m
Çevre : 155 mm

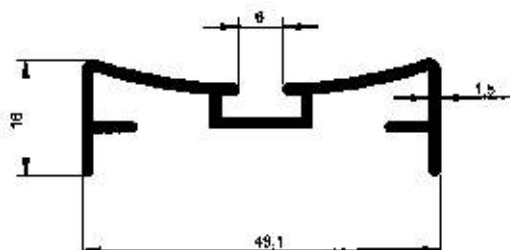

Profil No : 3141
Gramaj : 0.421 kg/m
Çevre : 207 mm

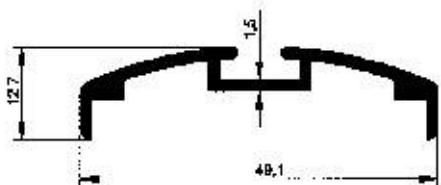

Profil No : 3142
Gramaj : 0.355 kg/m
Çevre : 156 mm

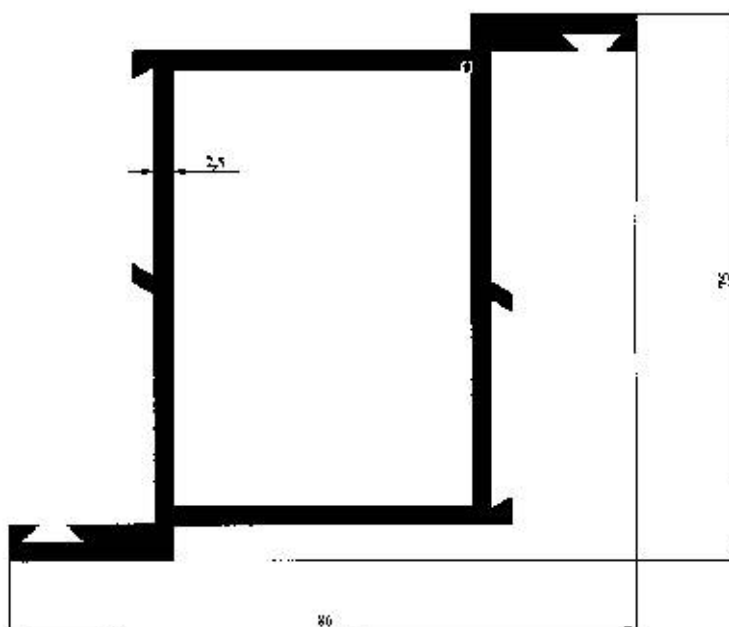

Profil No : 3204
Gramaj : 2.042 kg/m
Çevre : 376 mm

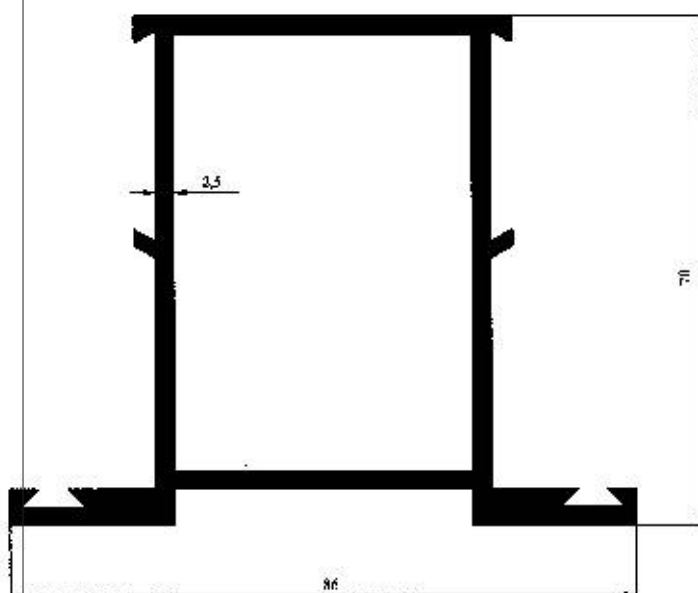

Profil No : 3203
Gramaj : 2.042 kg/m
Çevre : 376 mm

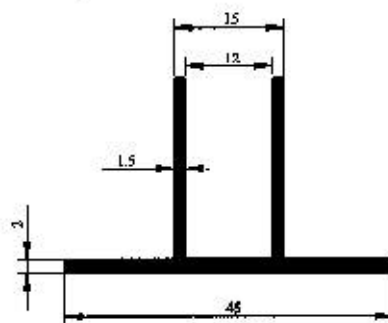

Profil No : 3189
Gramaj : 0.447 kg/m
Çevre : 194 mm

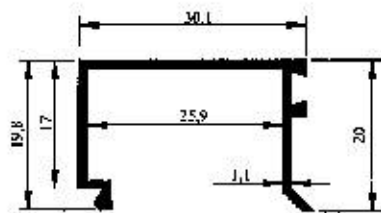
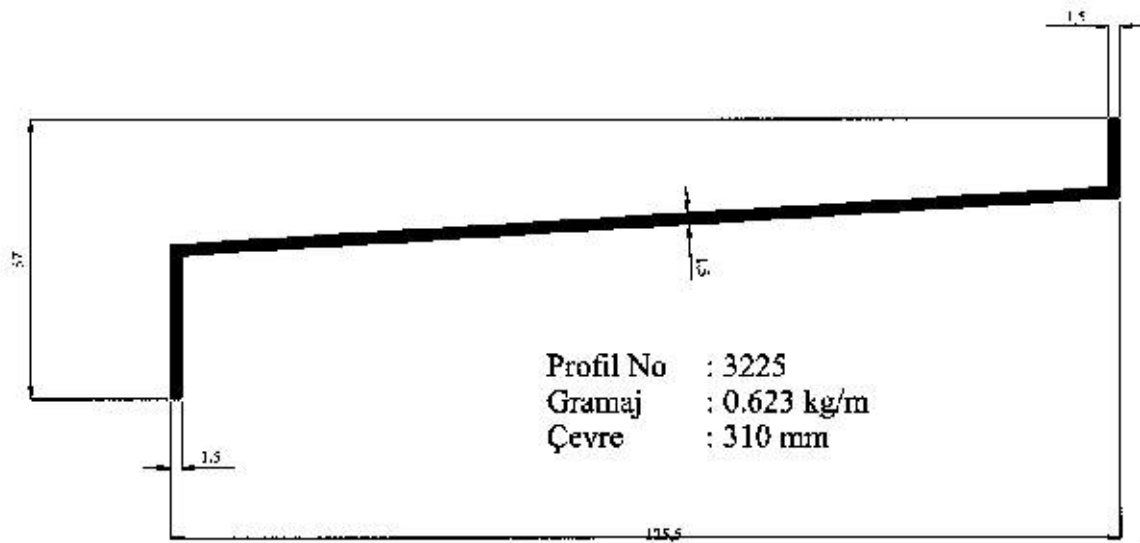

Profil No : 3636
 Gramaj : 0.234 kg/m
 Çevre : 153 mm

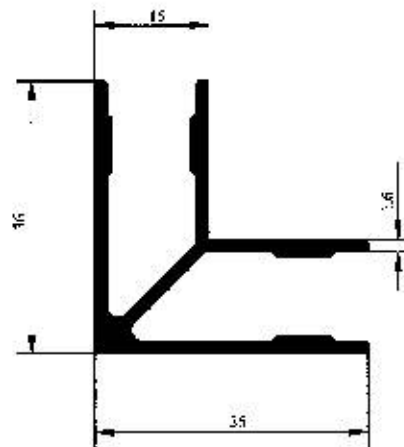

Profil No : 4489
 Gramaj : 0.640 kg/m
 Çevre : 257 mm

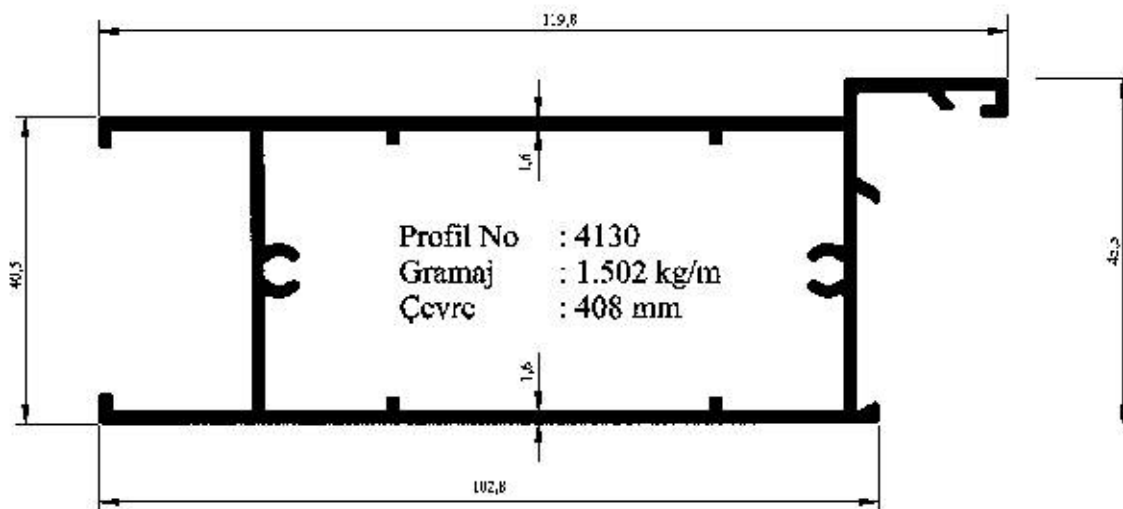

Hliníková okna a dveře
Windows And Doors Profiles

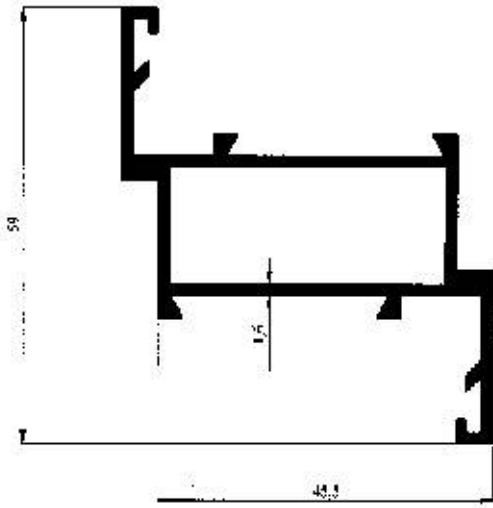

Profil No : 5194
Gramaj : 0.909 kg/m
Çevre : 284 mm

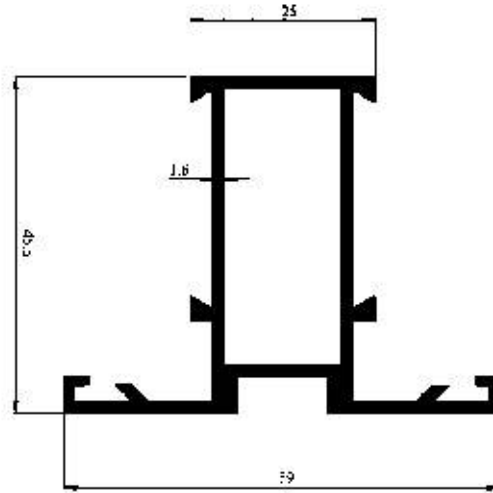

Profil No : 5195
Gramaj : 0.909 kg/m
Çevre : 284 mm

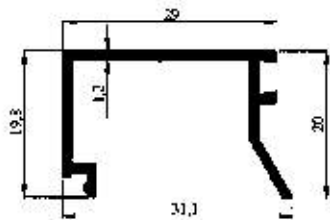

Profil No : 5198
Gramaj : 0.244 kg/m
Çevre : 151 mm

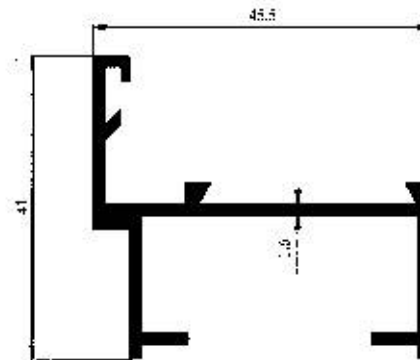

Profil No : 5214
Gramaj : 0.610 kg/m
Çevre : 271 mm

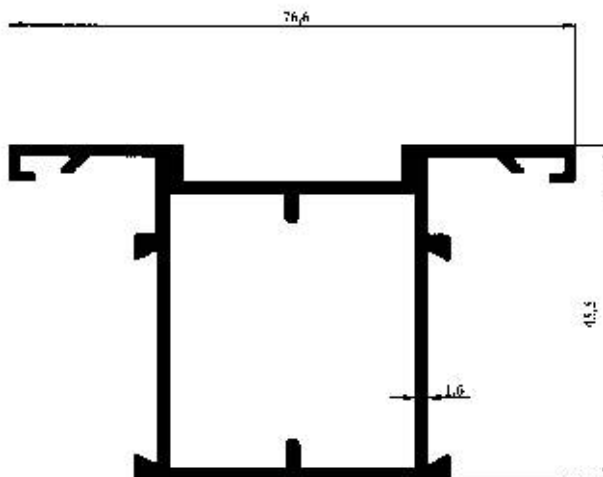

Profil No : 5224
Gramaj : 1.103 kg/m
Çevre : 312 mm

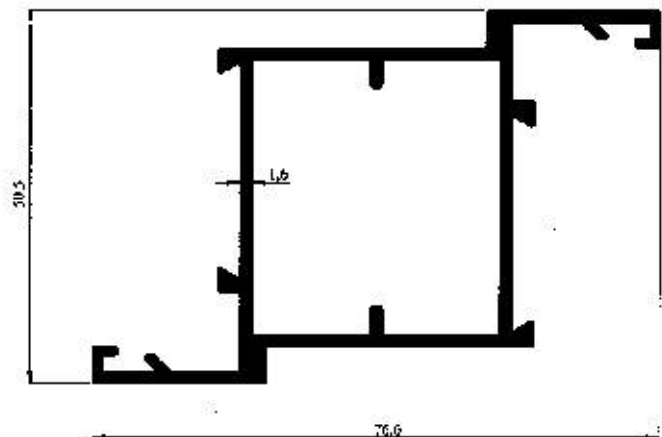

Profil No : 5225
Gramaj : 1.103 kg/m
Çevre : 312 mm



Hliníková okna a dveře Windows And Doors Profiles

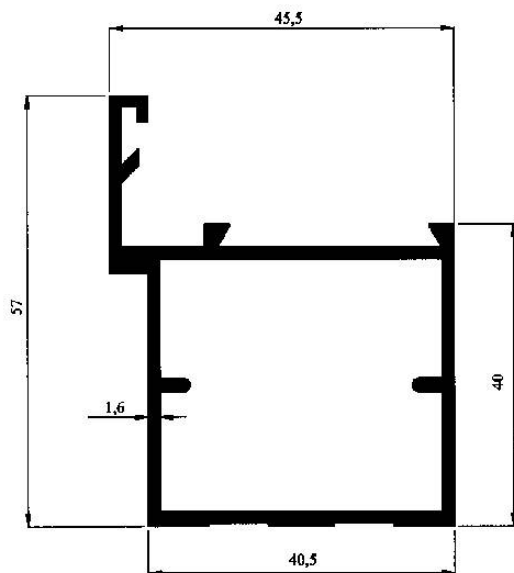

Profil No : 5243
Gramaj : 0.911 kg/m
Çevre : 240 mm

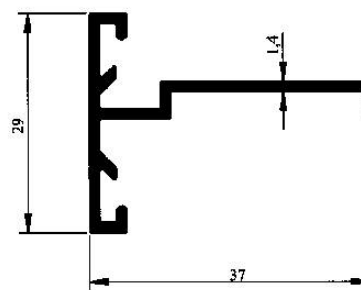

Profil No : 5274
Gramaj : 0.325 kg/m
Çevre : 168 mm

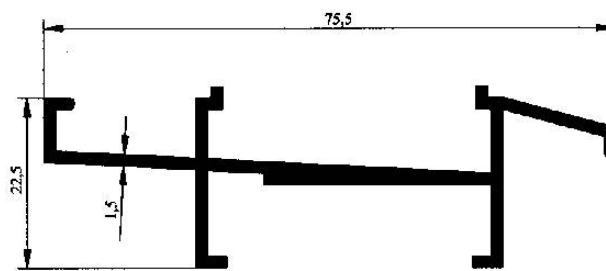

Profil No : 5392
Gramaj : 0.641 kg/m
Çevre : 288 mm



Alucomplast

**Facade System Profiles
Hliníkových Fasádních Systémů**

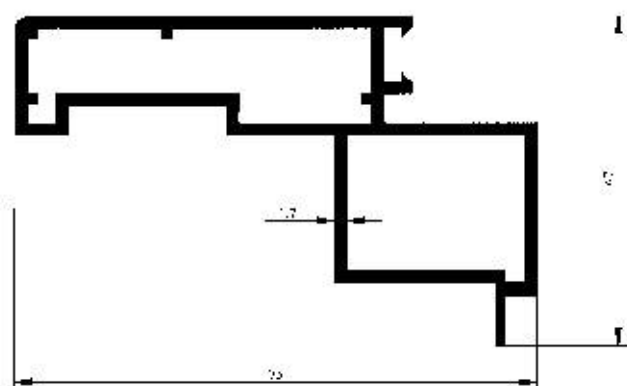

Profil No : 3645
Gramaj : 1.171 kg/m
Çevre : 272 mm

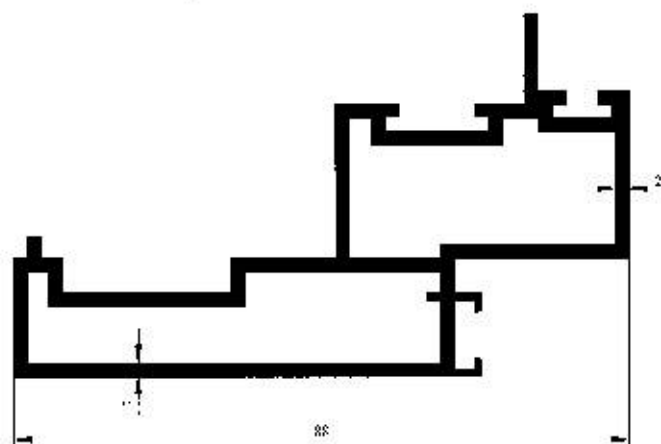

Profil No : 3655
Gramaj : 1.705 kg/m
Çevre : 350 mm

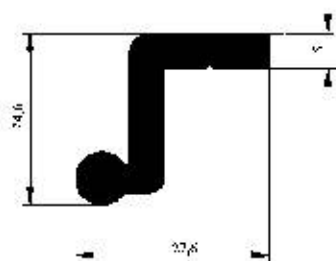

Profil No : 3676
Gramaj : 0.629 kg/m
Çevre : 101 mm

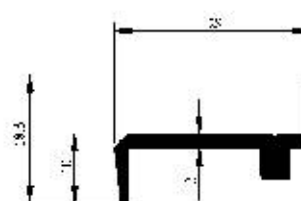

Profil No : 3656
Gramaj : 0.250 kg/m
Çevre : 100 mm

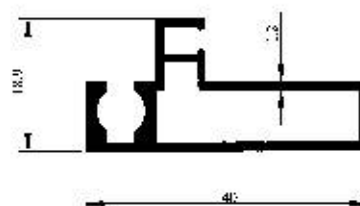

Profil No : 3674
Gramaj : 0.412 kg/m
Çevre : 151 mm

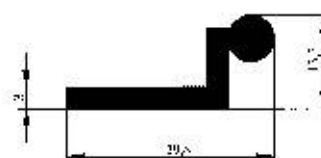

Profil No : 3675
Gramaj : 0.350 kg/m
Çevre : 84 mm

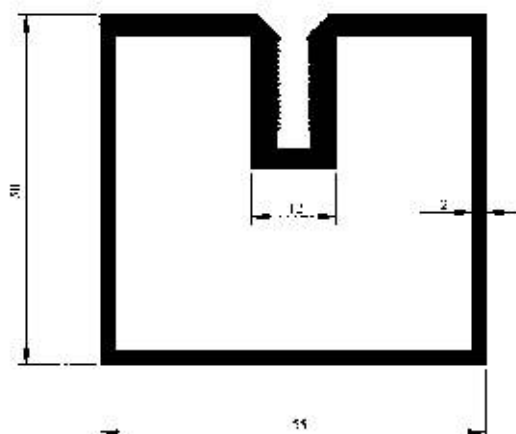

Profil No : 3678
Gramaj : 1.601 kg/m
Çevre : 256 mm

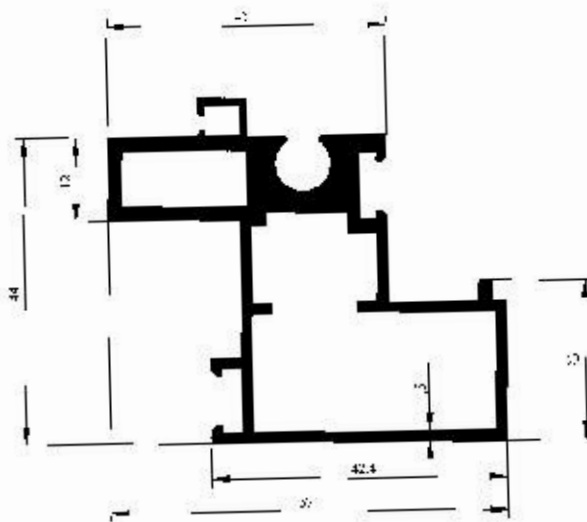
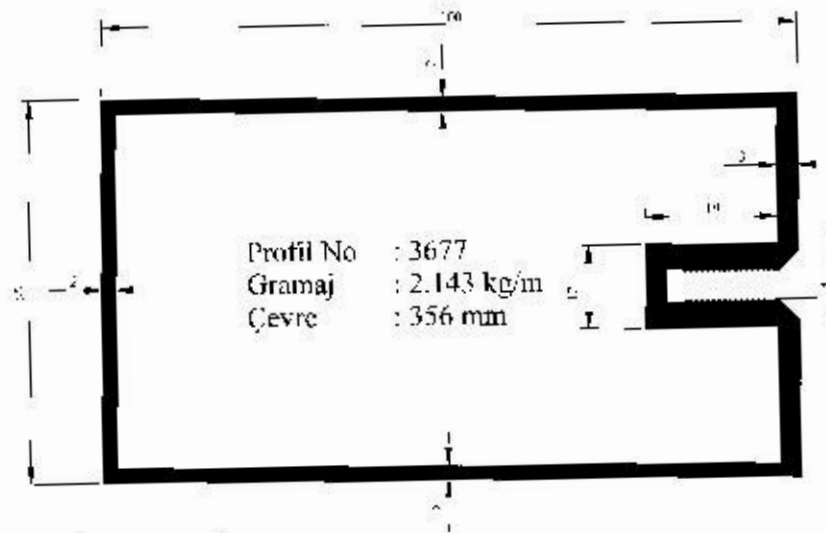

Profil No : 3679
Gramaj : 1.264 kg/m
Çevre : 285 mm

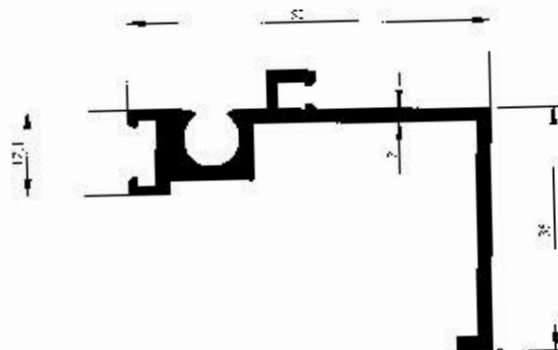

Profil No : 3681
Gramaj : 0.717 kg/m
Çevre : 253 mm

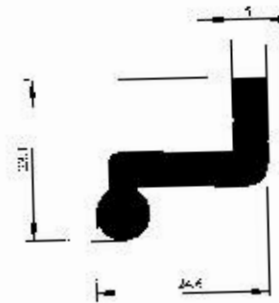

Profil No : 3680
Gramaj : 0.569 kg/m
Çevre : 92 mm

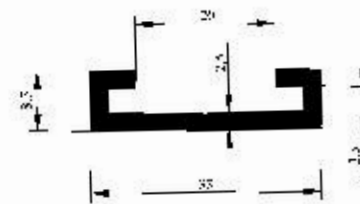

Profil No : 3682
Gramaj : 0.358 kg/m
Çevre : 111 mm

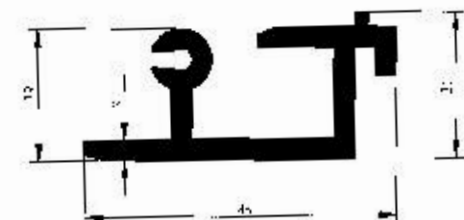

Profil No : 3683
Gramaj : 0.815 kg/m
Çevre : 208 mm

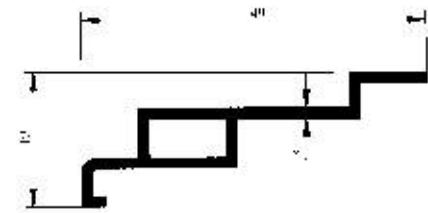
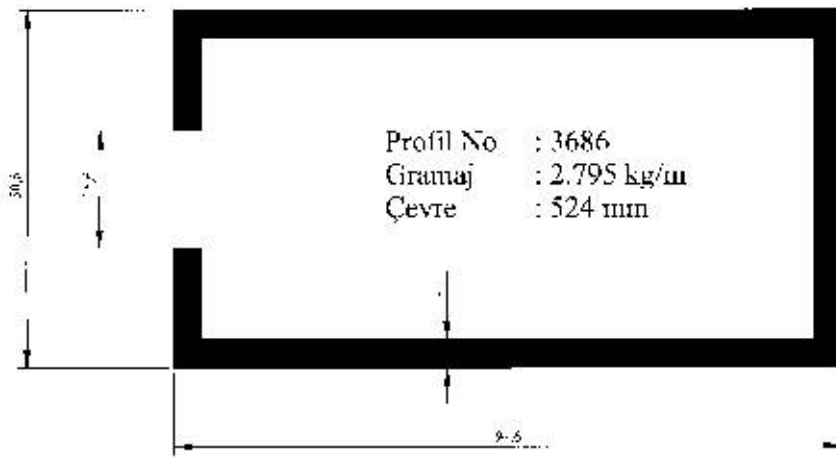

Profil No : 3692
 Gramaj : 0.349 kg/m
 Çevre : 139 mm

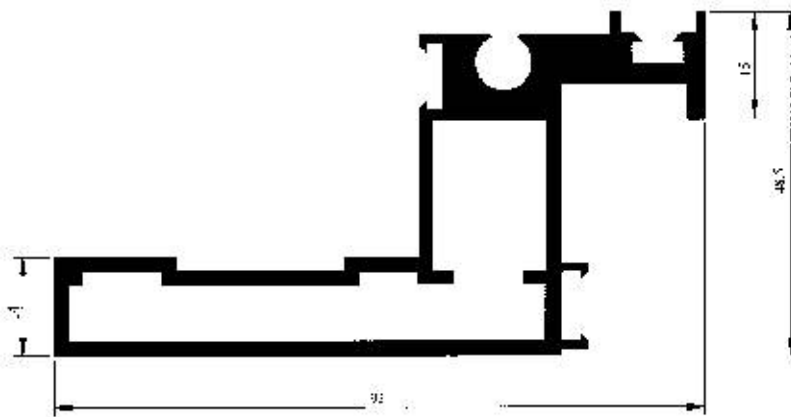

Profil No : 3691
 Gramaj : 1.894 kg/m
 Çevre : 393 mm

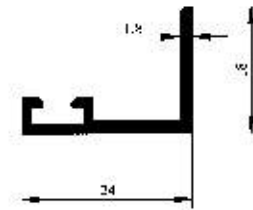

Profil No : 3693
 Gramaj : 0.216 kg/m
 Çevre : 104 mm

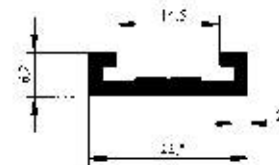

Profil No : 3767
 Gramaj : 0.205 kg/m
 Çevre : 74 mm

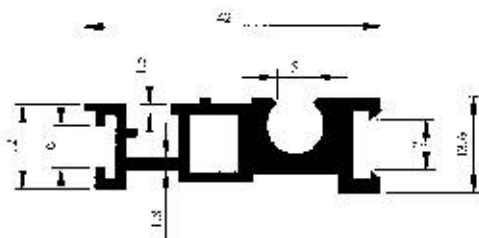

Profil No : 3744
 Gramaj : 0.638 kg/m
 Çevre : 180 mm

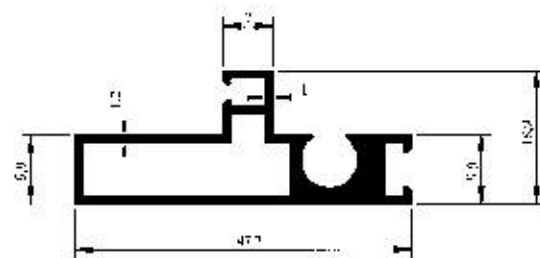

Profil No : 3746
 Gramaj : 0.534 kg/m
 Çevre : 177 mm

Facade System Profiles
Hliníkových Fasádních Systémů

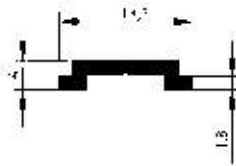

Profil No : 3768
 Gramaj : 0.110 kg/m
 Çevre : 49 mm

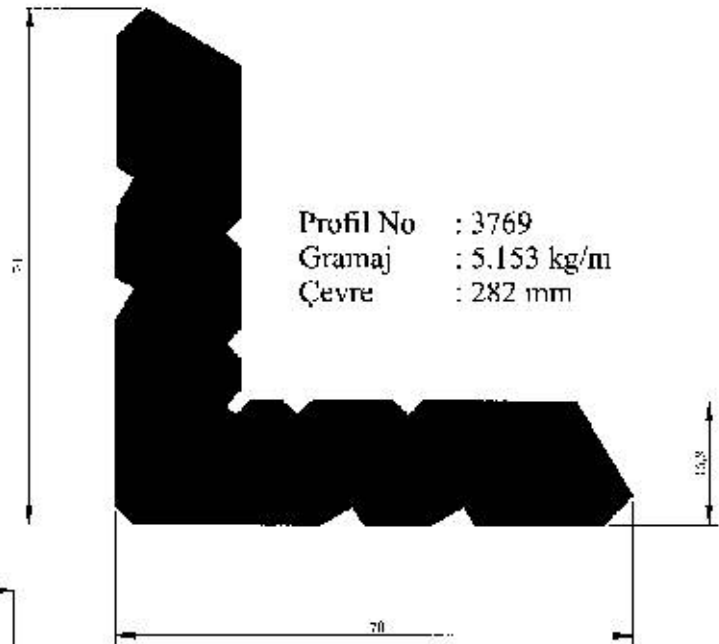

Profil No : 3769
 Gramaj : 5.153 kg/m
 Çevre : 282 mm

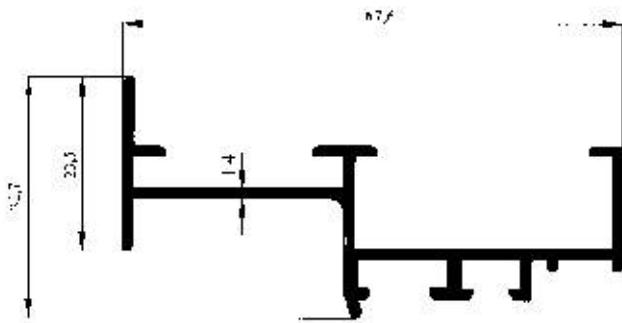

Profil No : 4258
 Gramaj : 0.637 kg/m
 Çevre : 319 mm

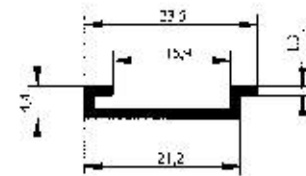

Profil No : 4259
 Gramaj : 0.114 kg/m
 Çevre : 66 mm



Profil No : 4260
 Gramaj : 0.231 kg/m
 Çevre : 61 mm

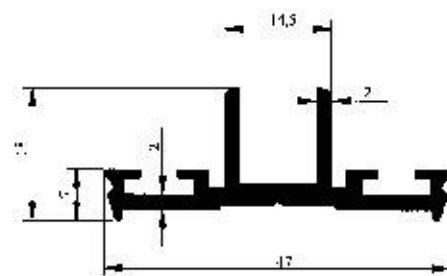

Profil No : 4261
 Gramaj : 0.546 kg/m
 Çevre : 197 mm



Profil No : 3694
 Gramaj : 0.127 kg/m
 Çevre : 54 mm

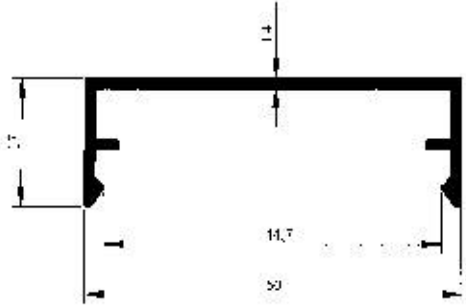

Profil No : 4262
 Gramaj : 0.341 kg/m
 Çevre : 178 mm

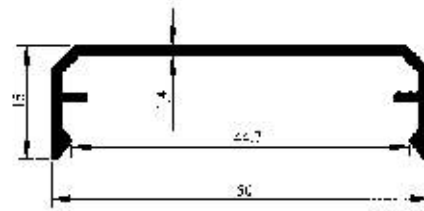

Profil No : 4263
 Gramaj : 0.314 kg/m
 Çevre : 164 mm

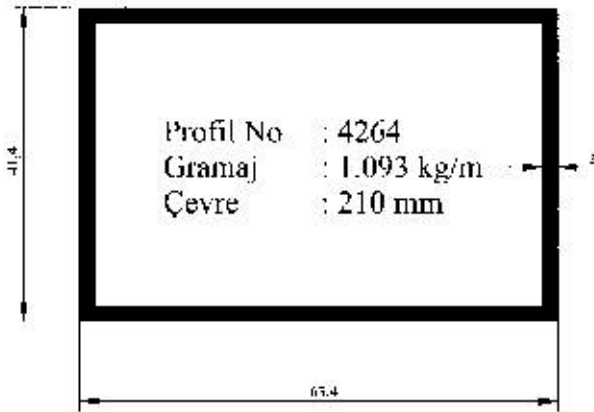

Profil No : 4264
 Gramaj : 1.093 kg/m
 Çevre : 210 mm

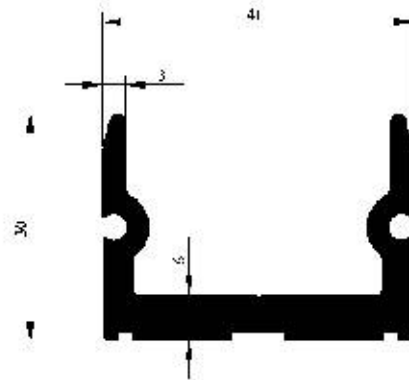

Profil No : 4265
 Gramaj : 1.100 kg/m
 Çevre : 205 mm

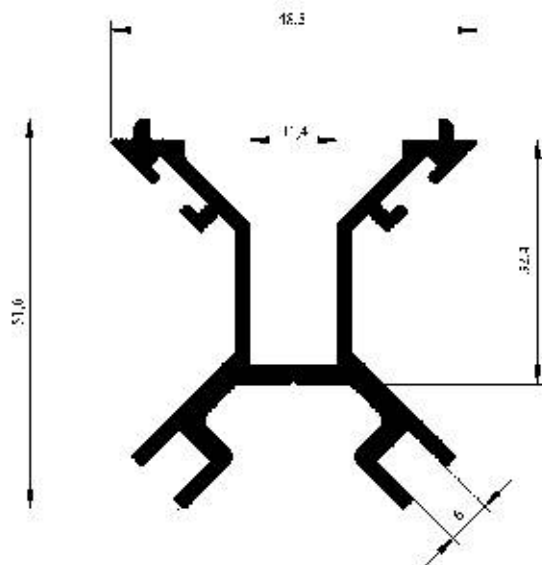

Profil No : 4266
 Gramaj : 1.130 kg/m
 Çevre : 362 mm

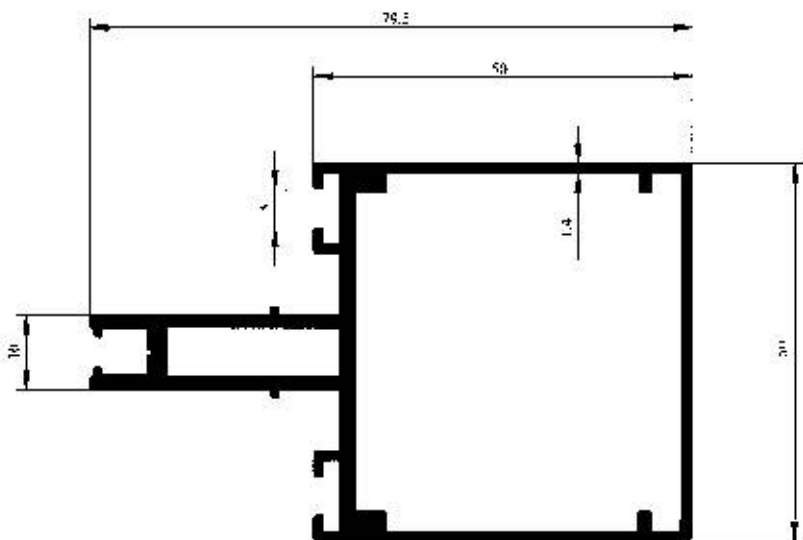

Profil No : 4269
 Gramaj : 1.333 kg/m
 Çevre : 324 mm

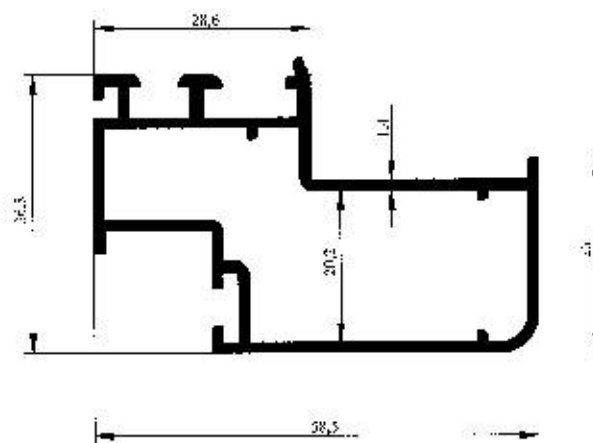
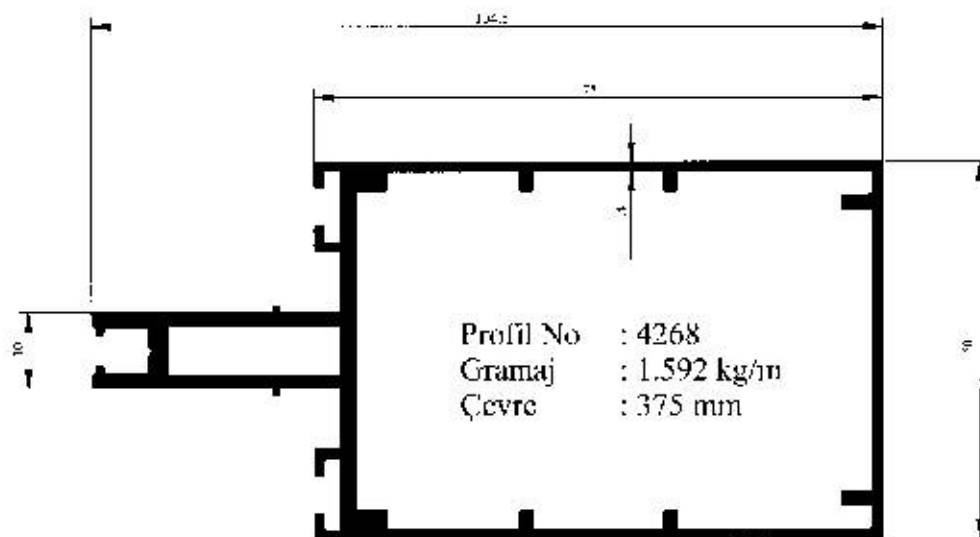
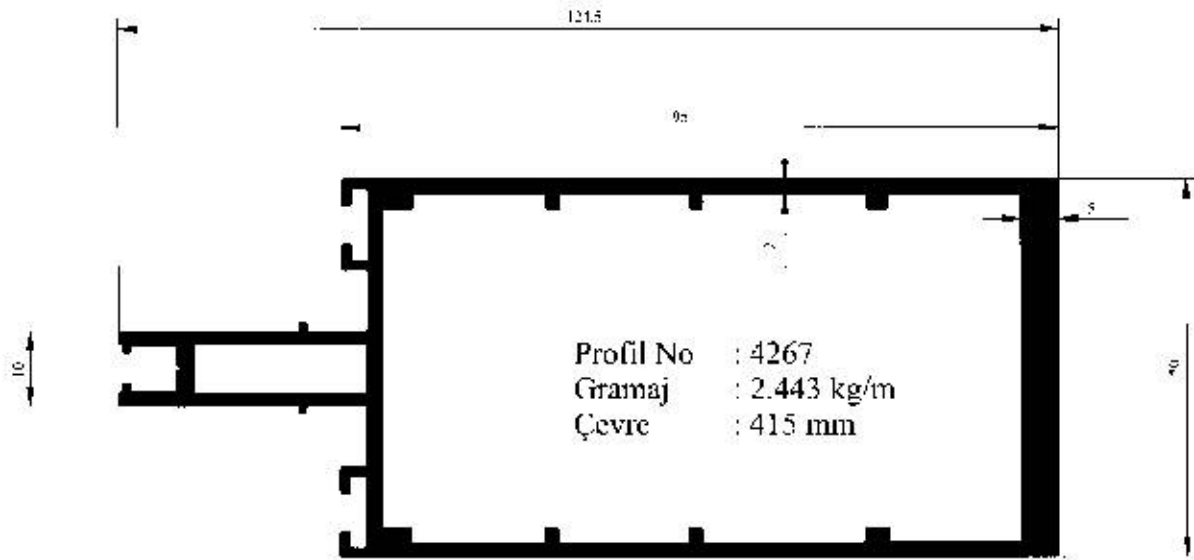

Profil No : 4270
Gramaj : 0.849 kg/m
Çevre : 263 mm

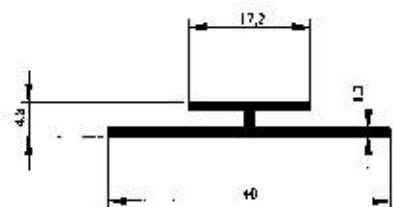

Profil No : 2288
Gramaj : 0.202 kg/m
Çevre : 122 mm

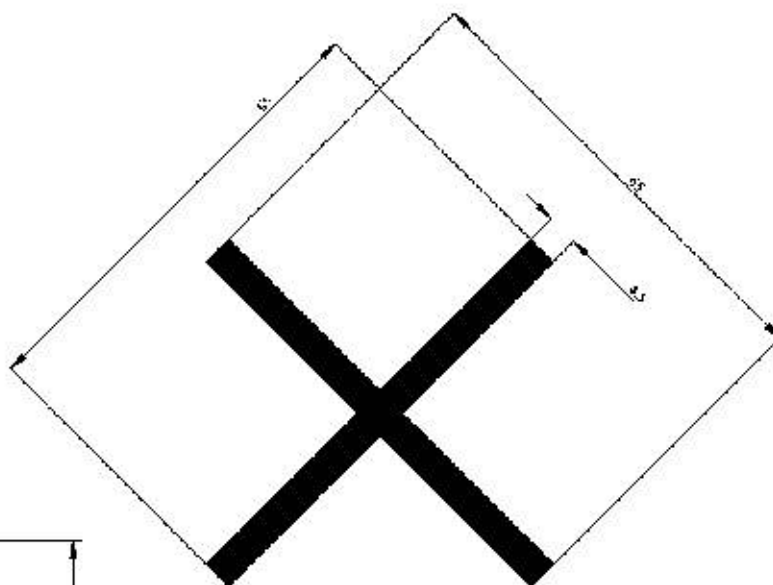

Profil No : 3604
Gramaj : 1.530 kg/m
Çevre : 260 mm

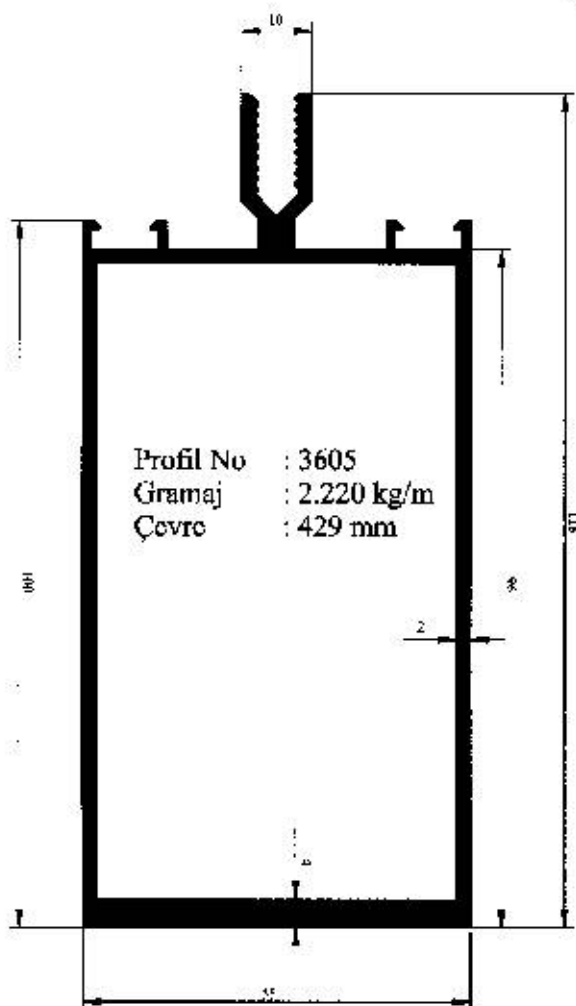

Profil No : 3605
Gramaj : 2.220 kg/m
Çevre : 429 mm

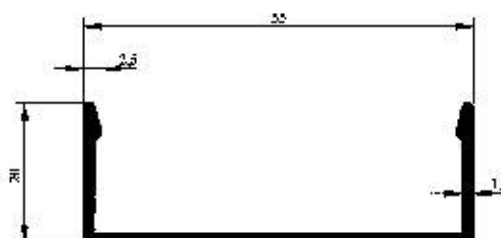

Profil No : 3606
Gramaj : 0.387 kg/m
Çevre : 187 mm

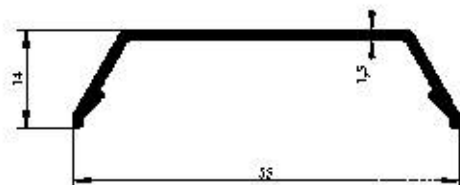

Profil No : 3608
Gramaj : 0.299 kg/m
Çevre : 144 mm

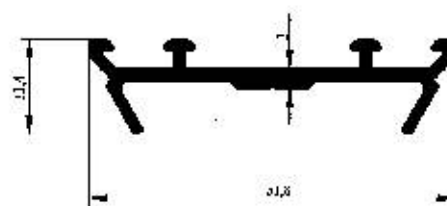

Profil No : 3607
Gramaj : 0.459 kg/m
Çevre : 180 mm

Facade System Profiles
Hliníkových Fasádních Systémů

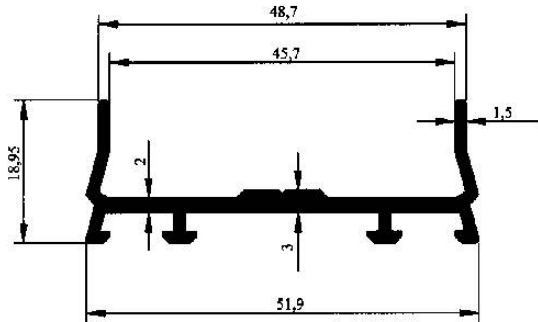

Profil No : 3609
Gramaj : 0.505 kg/m
Çevre : 205 mm

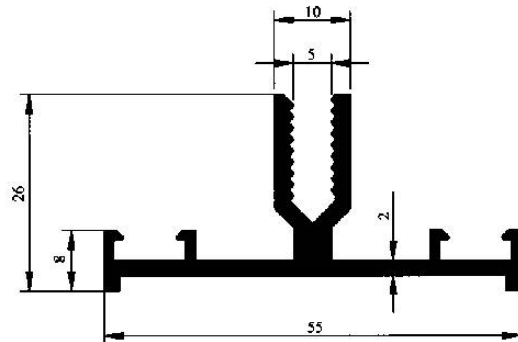

Profil No : 3614
Gramaj : 0.671 kg/m
Çevre : 249 mm

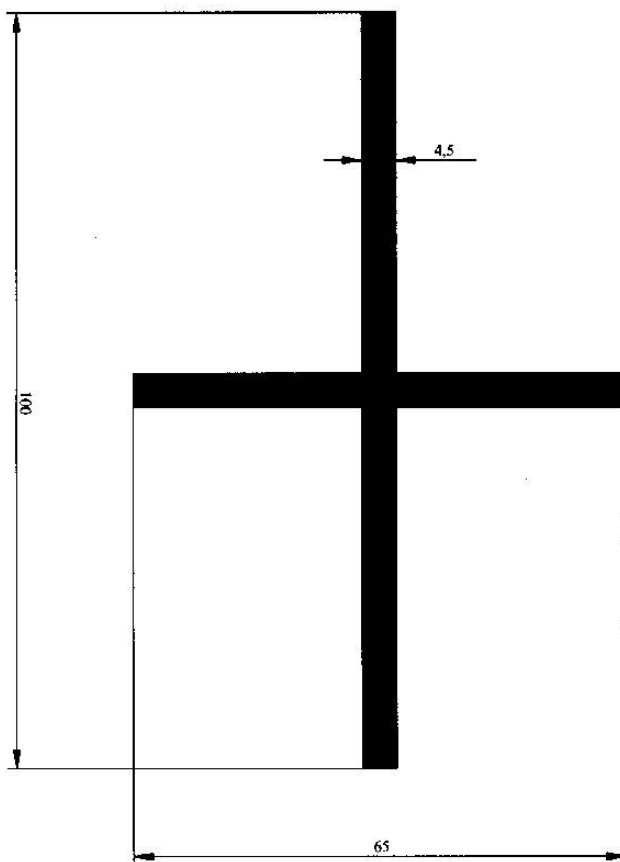

Profil No : 3617
Gramaj : 1.957 kg/m
Çevre : 330 mm

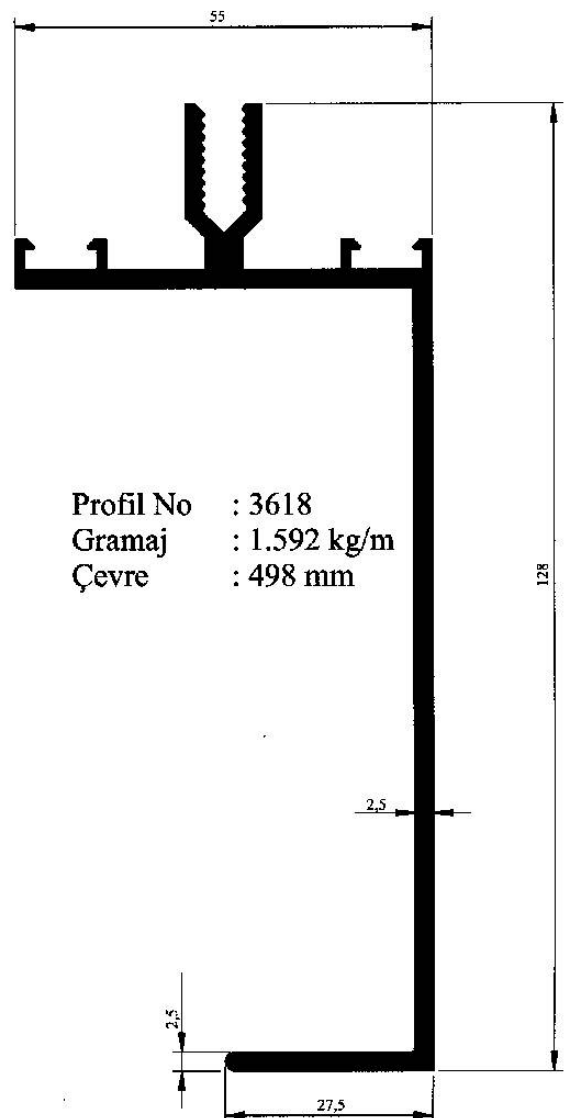

Profil No : 3618
Gramaj : 1.592 kg/m
Çevre : 498 mm

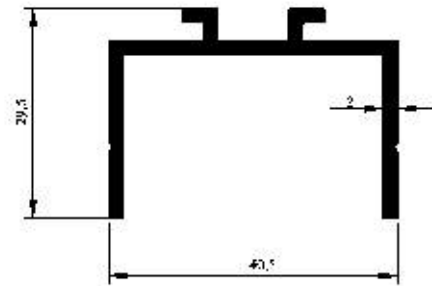
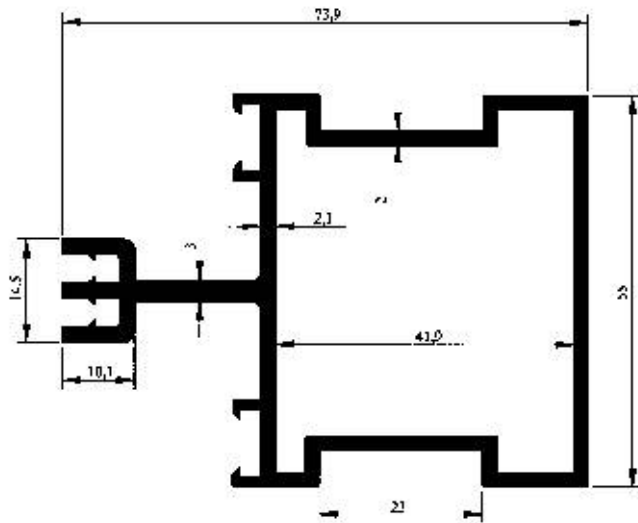

Profil No : 3669
Gramaj : 0.549 kg/m
Çevre : 208 mm

Profil No : 3647
Gramaj : 1.609 kg/m
Çevre : 377 mm

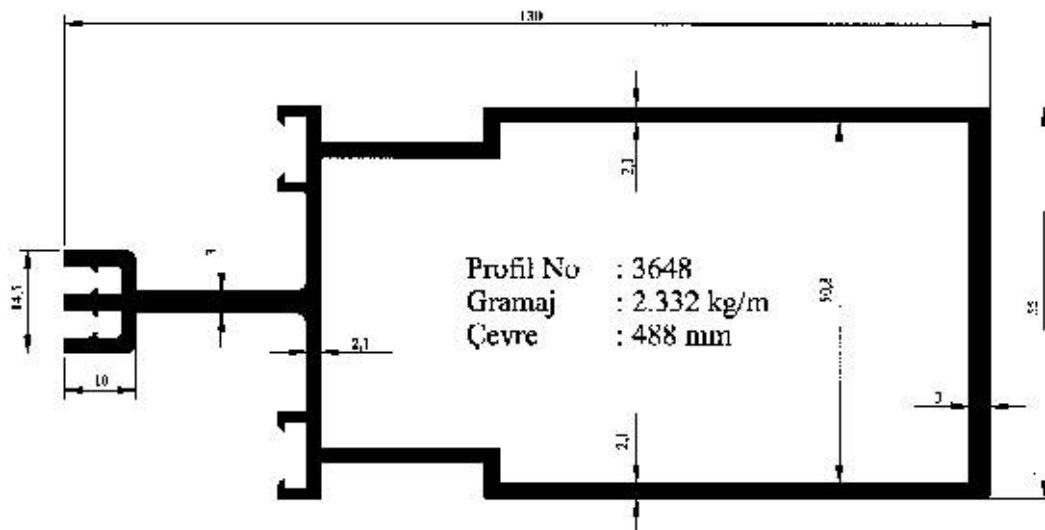

Profil No : 3648
Gramaj : 2.332 kg/m
Çevre : 488 mm

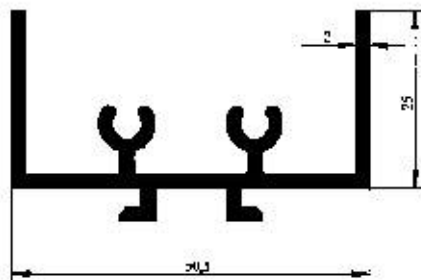

Profil No : 3670
Gramaj : 0.783 kg/m
Çevre : 293 mm

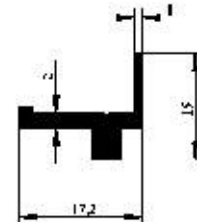

Profil No : 3713
Gramaj : 0.170 kg/m
Çevre : 67 mm

Facade System Profiles
Hliníkových Fasádních Systémů

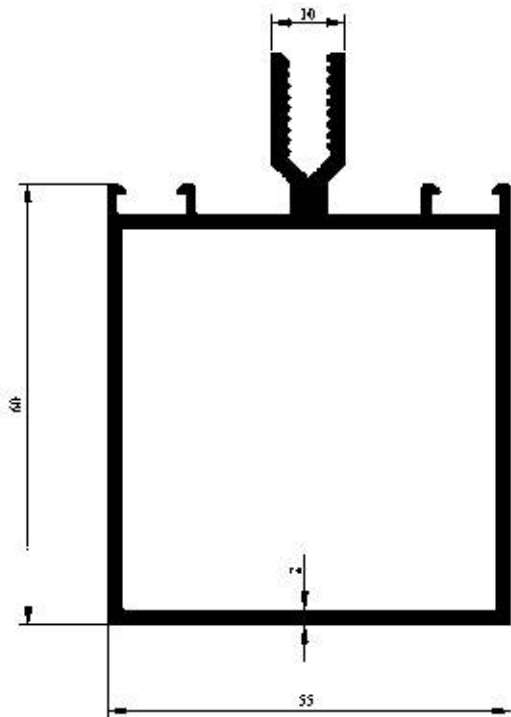

Profil No : 3671
Gramaj : 1.510 kg/m
Çevre : 554 mm

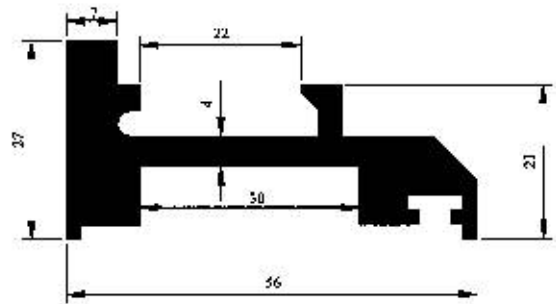

Profil No : 3714
Gramaj : 1.430 kg/m
Çevre : 219 mm

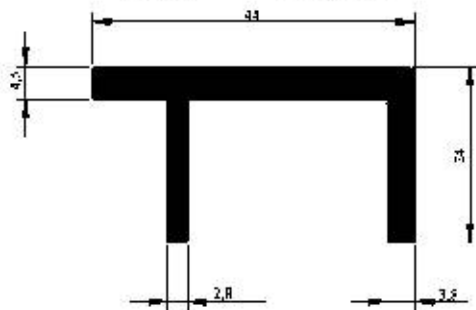

Profil No : 3129
Gramaj : 0.884 kg/m
Çevre : 174 mm

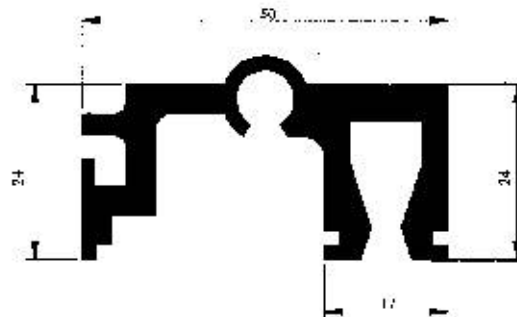

Profil No : 3716
Gramaj : 1.380 kg/m
Çevre : 275 mm

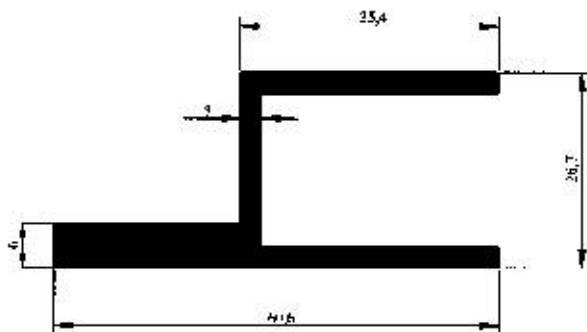

Profil No : 3130
Gramaj : 1.154 kg/m
Çevre : 239 mm

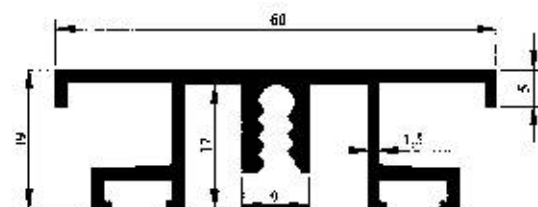

Profil No : 3702
Gramaj : 0.750 kg/m
Çevre : 322 mm

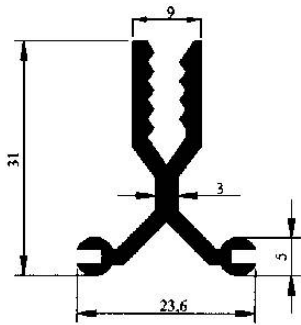

Profil No : 3703
Gramaj : 0.270 kg/m
Çevre : 165 mm

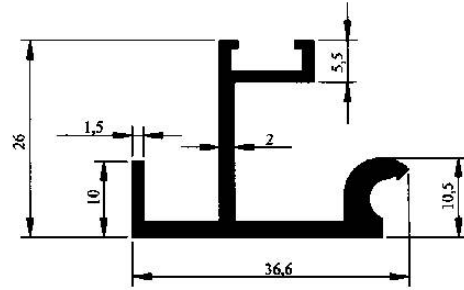

Profil No : 3704
Gramaj : 0.480 kg/m
Çevre : 192 mm

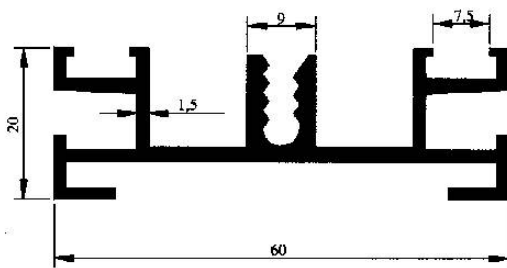

Profil No : 3705
Gramaj : 0.782 kg/m
Çevre : 335 mm

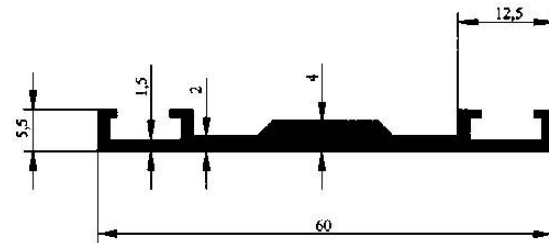

Profil No : 3707
Gramaj : 0.457 kg/m
Çevre : 166 mm

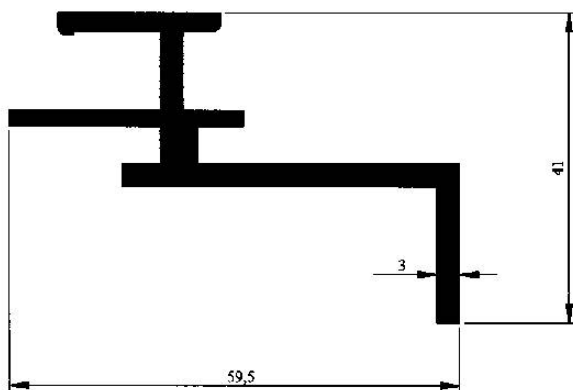

Profil No : 4012
Gramaj : 0.976 kg/m
Çevre : 260 mm

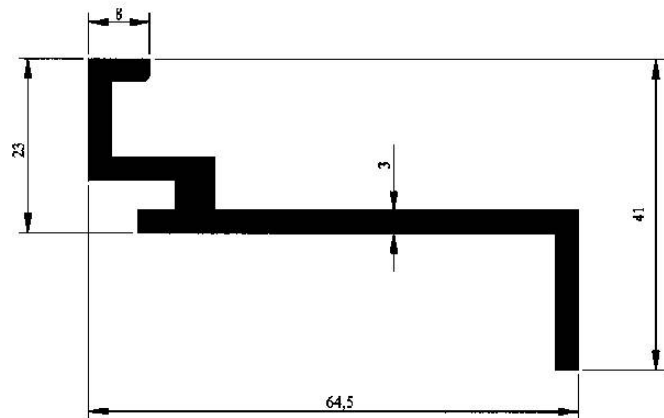

Profil No : 4011
Gramaj : 0.951 kg/m
Çevre : 276 mm

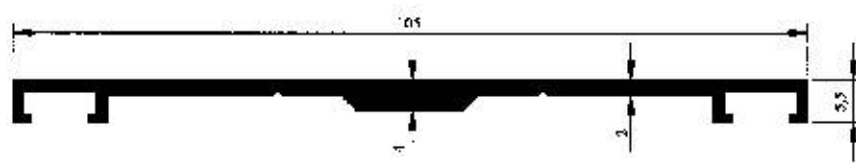

Profil No : 3706
Gramaj : 0.696 kg/m
Çevre : 261 mm

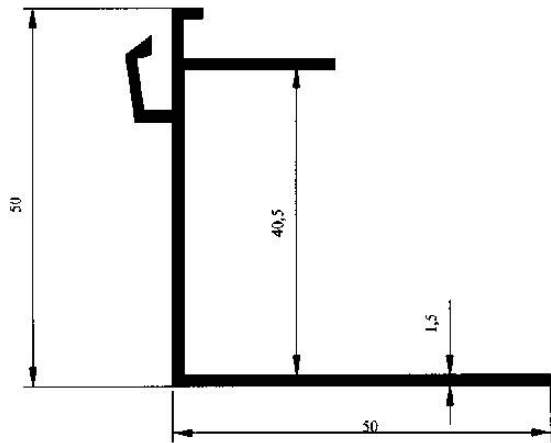

Profil No : 2871
Gramaj : 0.536 kg/m
Çevre : 277 mm

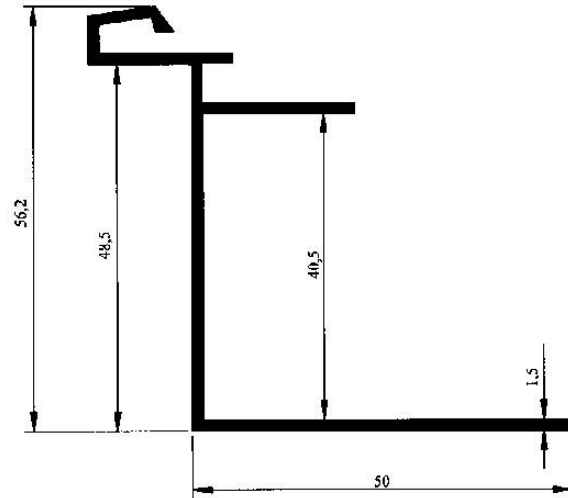

Profil No : 2872
Gramaj : 0.596 kg/m
Çevre : 307 mm

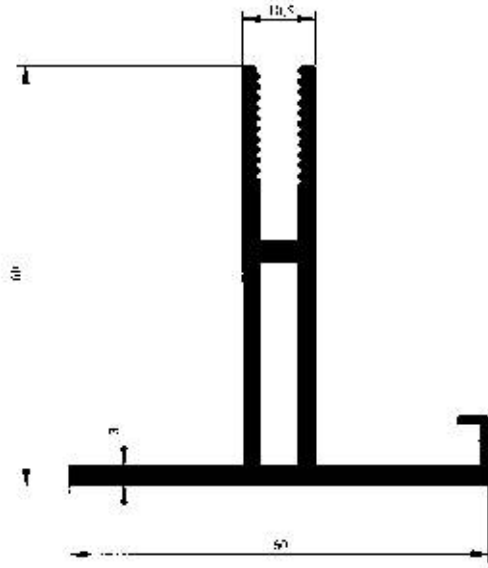

Profil No : 2243
 Gramaj : 1.315 kg/m
 Çevre : 316 mm

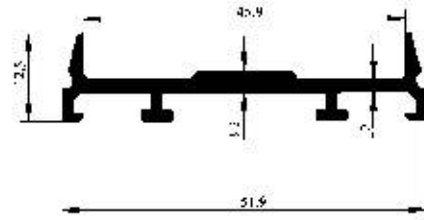

Profil No : 2787
 Gramaj : 0.470 kg/m
 Çevre : 177 mm

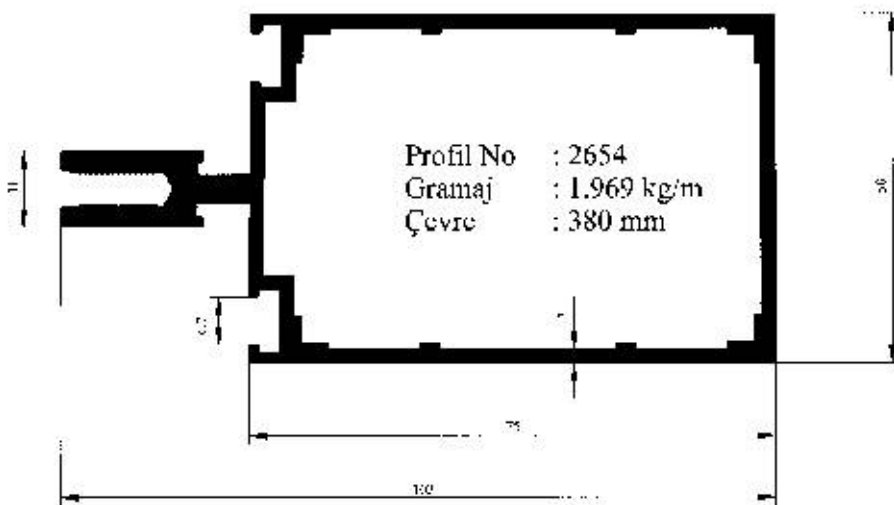

Profil No : 2654
 Gramaj : 1.969 kg/m
 Çevre : 380 mm

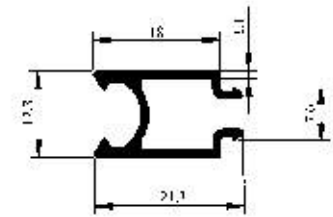

Profil No : 2665
 Gramaj : 0.196 kg/m
 Çevre : 119 mm

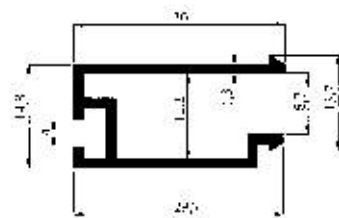

Profil No : 3549
 Gramaj : 0.301 kg/m
 Çevre : 173 mm

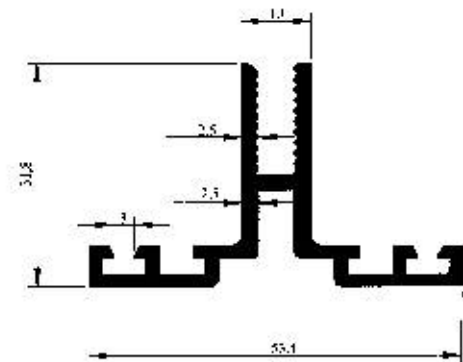

Profil No : 3556
 Gramaj : 0.756 kg/m
 Çevre : 284 mm

Facade System Profiles
Hliníkových Fasádních Systémů

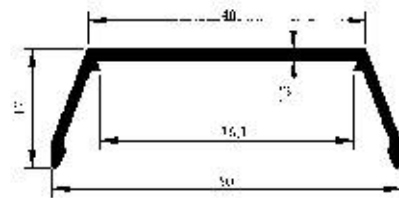
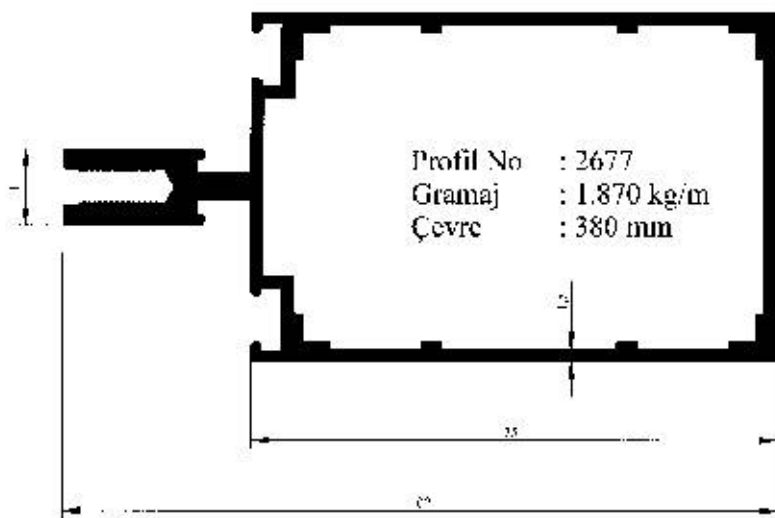

Profil No : 2784
 Gramaj : 0.304 kg/m
 Çevre : 151 mm

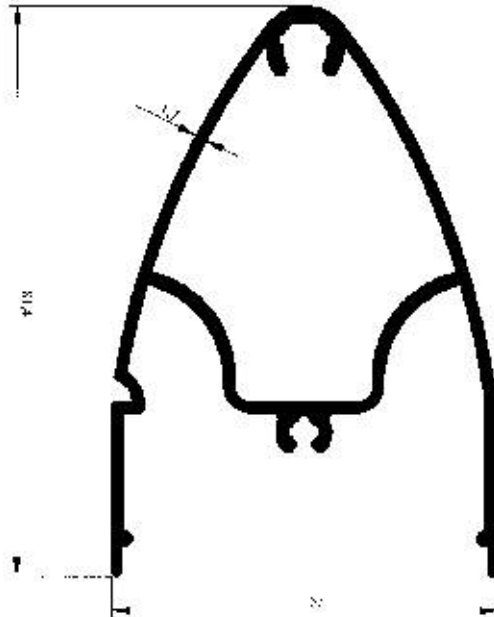
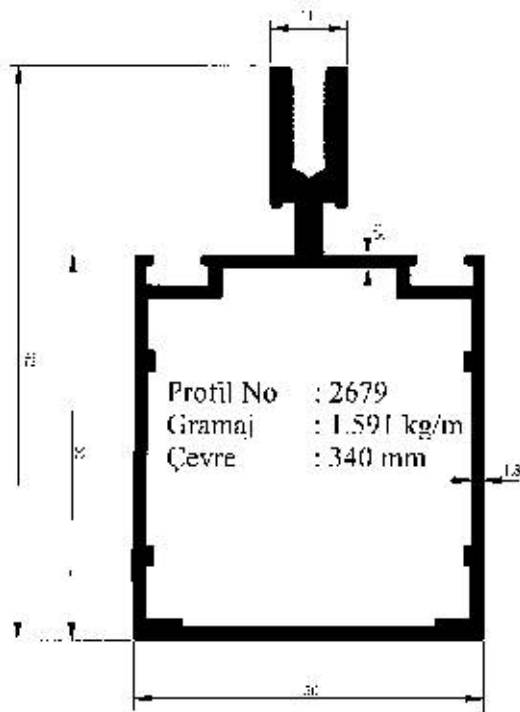

Profil No : 2788
 Gramaj : 1.328 kg/m
 Çevre : 364 mm

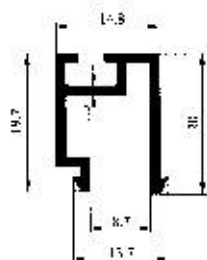

Profil No : 3550
 Gramaj : 0.230 kg/m
 Çevre : 133 mm

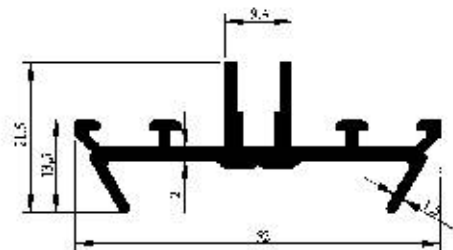

Profil No : 3753
 Gramaj : 0.588 kg/m
 Çevre : 231 mm

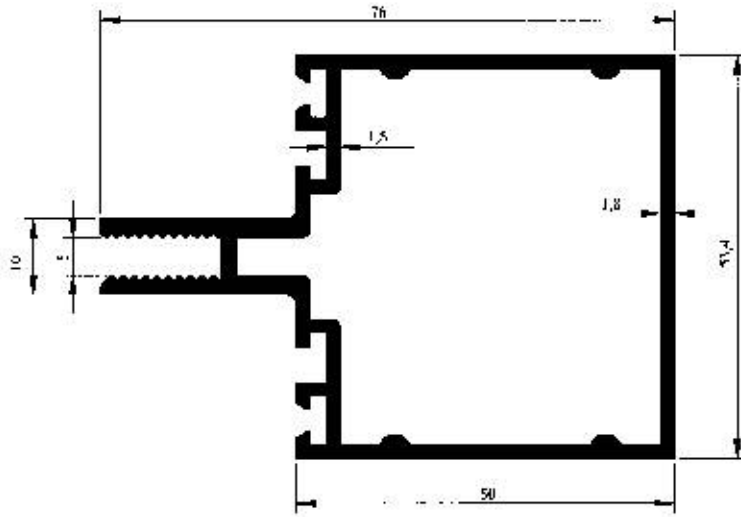

Profil No : 3557
 Gramaj : 1.474 kg/m
 Çevre : 347 mm

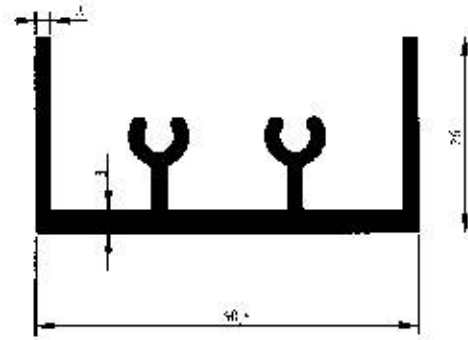

Profil No : 3775
 Gramaj : 0.871 kg/m
 Çevre : 277 mm

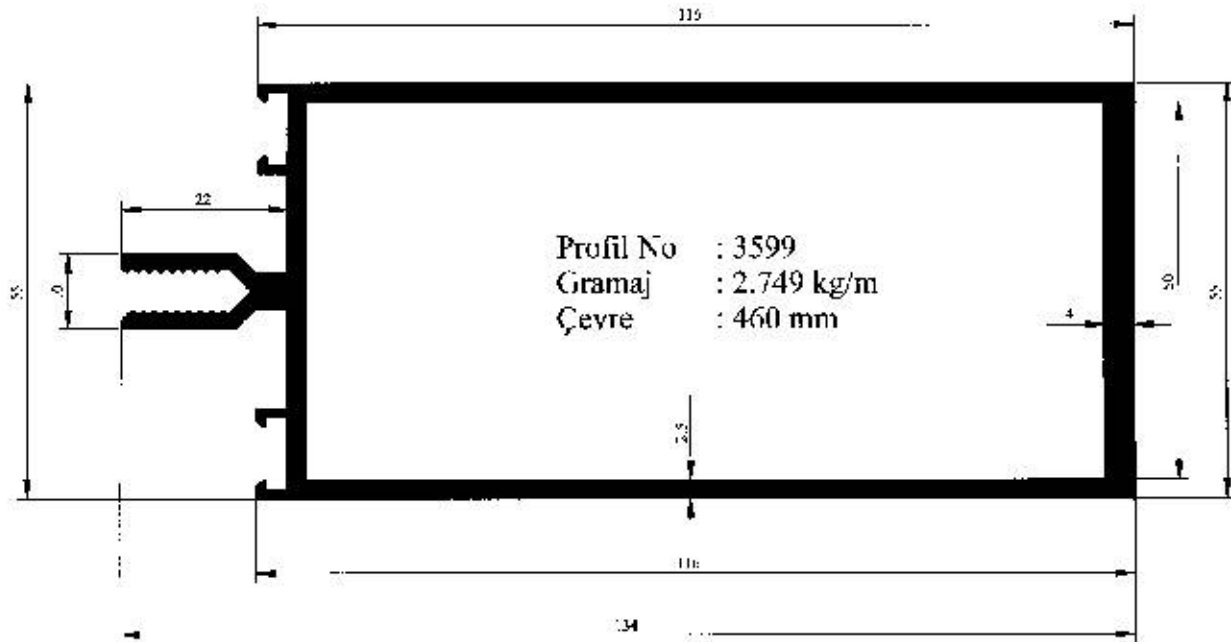

Profil No : 3599
 Gramaj : 2.749 kg/m
 Çevre : 460 mm

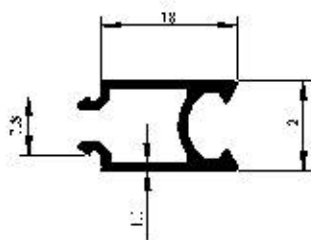

Profil No : 3783
 Gramaj : 0.195 kg/m
 Çevre : 116 mm

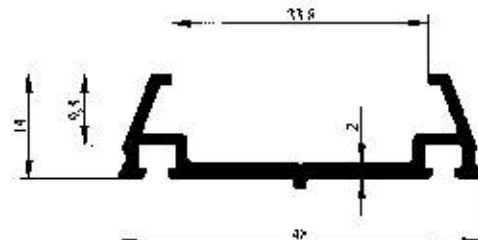

Profil No : 4013
 Gramaj : 0.411 kg/m
 Çevre : 177 mm

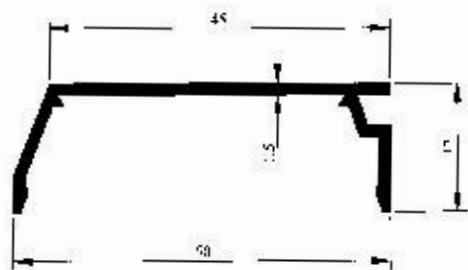
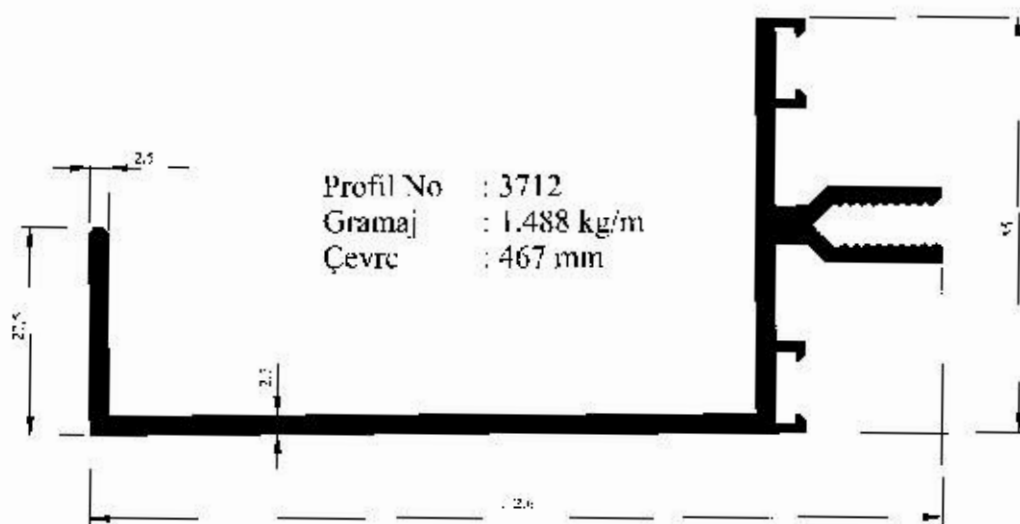
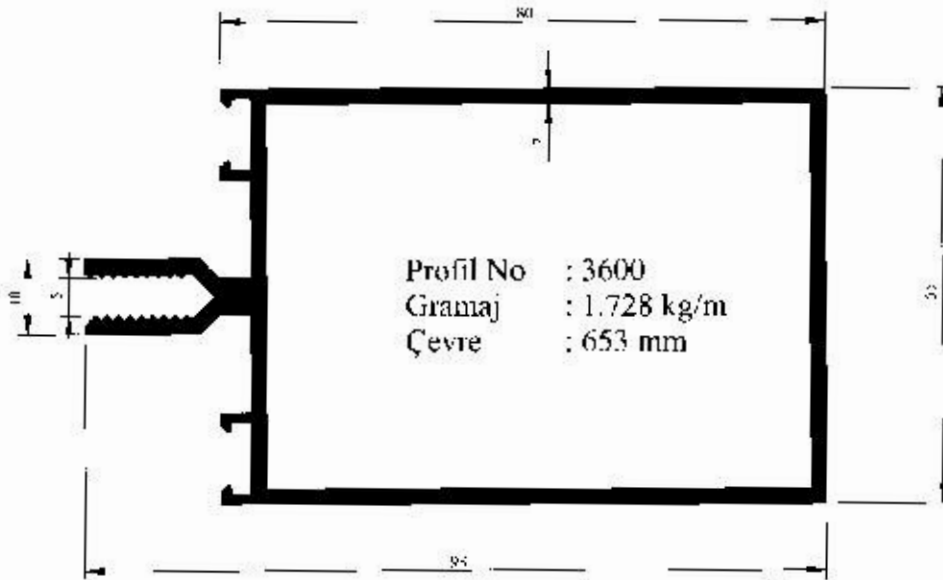

Profil No : 4014
 Gramaj : 0.333 kg/m
 Çevre : 166 mm

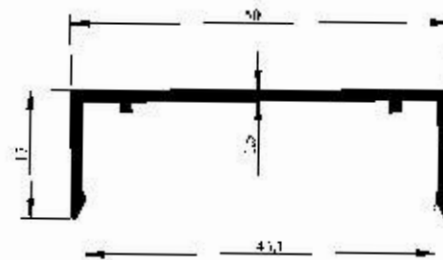

Profil No : 4015
 Gramaj : 0.341 kg/m
 Çevre : 170 mm

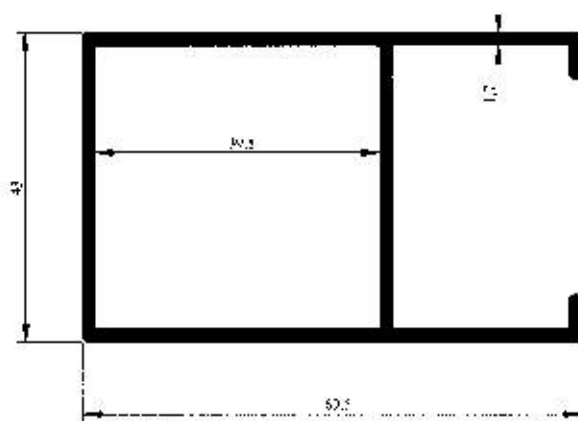
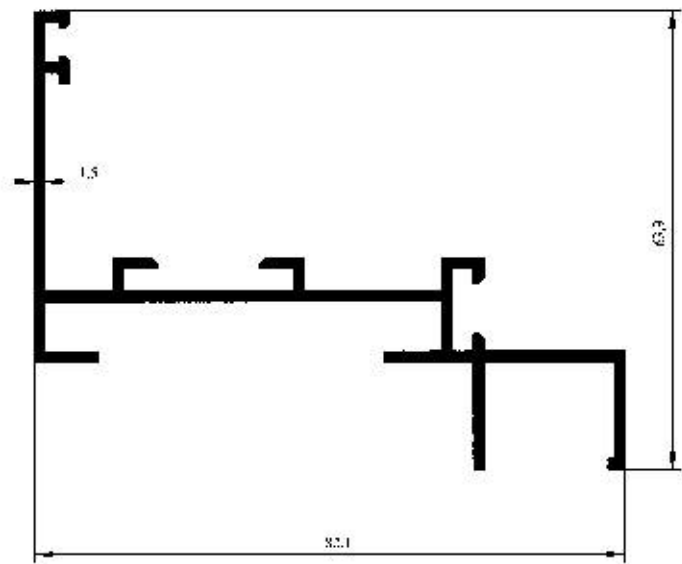
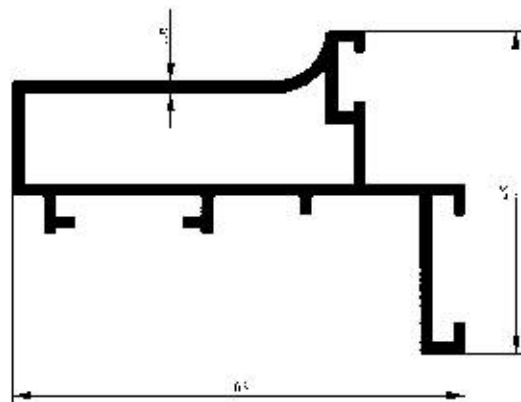
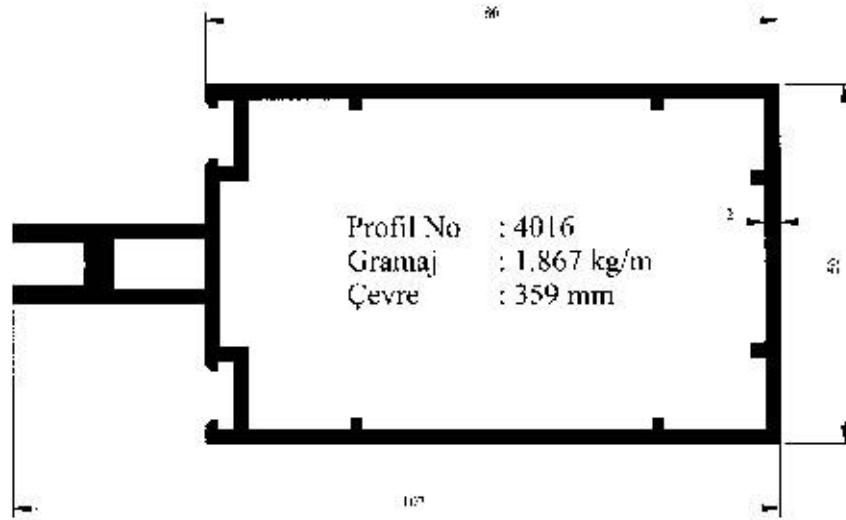

Profil No : 4018
 Gramaj : 0.919 kg/m
 Çevre : 445 mm

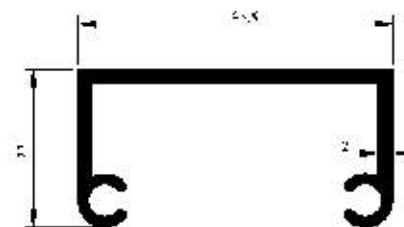

Profil No : 4019
 Gramaj : 1.049 kg/m
 Çevre : 295 mm

Profil No : 4020
 Gramaj : 0.515 kg/m
 Çevre : 205 mm

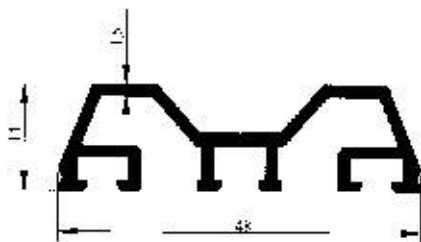

Profil No : 4024
Gramaj : 0.493 kg/m
Çevre : 237 mm

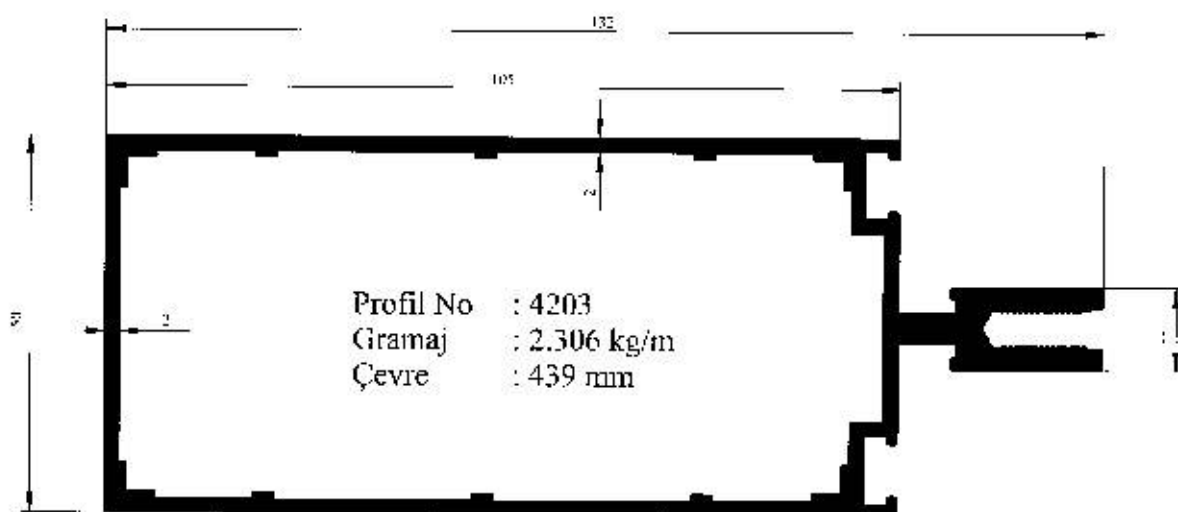



Alucomplast

**Hliníková okna a hliníkové
dveře s tepelným mostem**

Hliníková okna a hliníkové
dveře s tepelným mostem

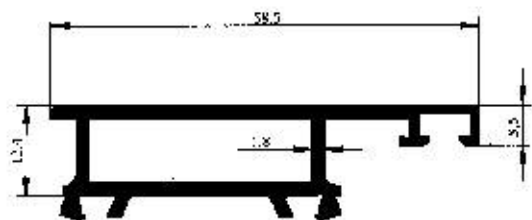

Profil No : 2305
Gramaj : 0.653 kg/m
Çevre : 200 mm

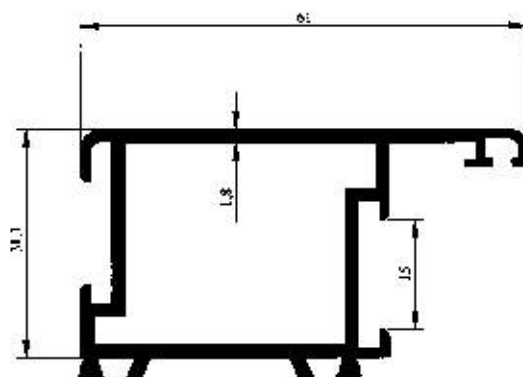

Profil No : 2306
Gramaj : 0.939 kg/m
Çevre : 271 mm

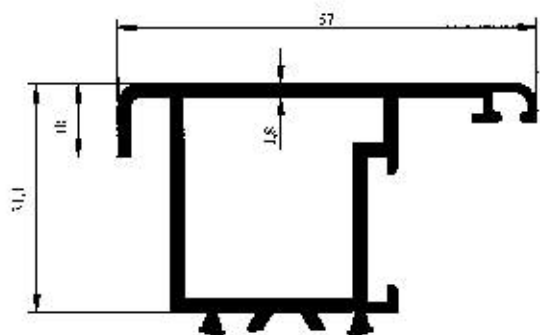

Profil No : 2307
Gramaj : 0.851 kg/m
Çevre : 256 mm

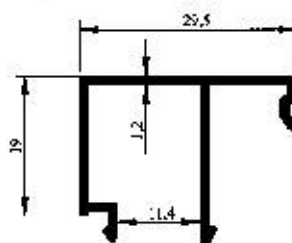

Profil No : 2308
Gramaj : 0.276 kg/m
Çevre : 169 mm

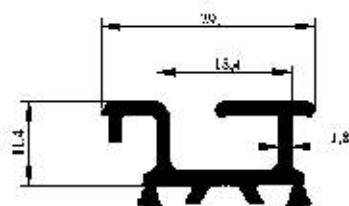

Profil No : 2309
Gramaj : 0.376 kg/m
Çevre : 153 mm

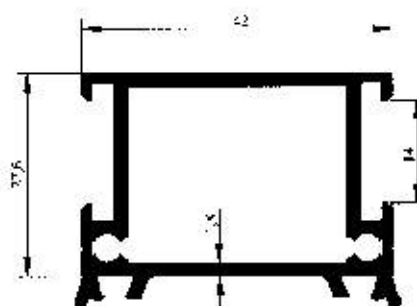

Profil No : 2310
Gramaj : 0.797 kg/m
Çevre : 210 mm

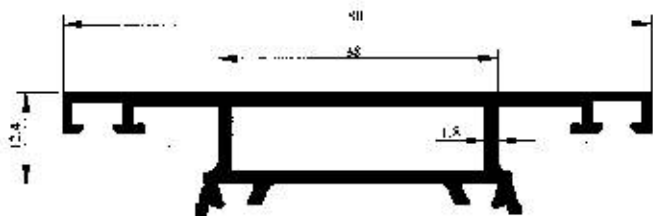

Profil No : 2311
Gramaj : 0.818 kg/m
Çevre : 275 mm

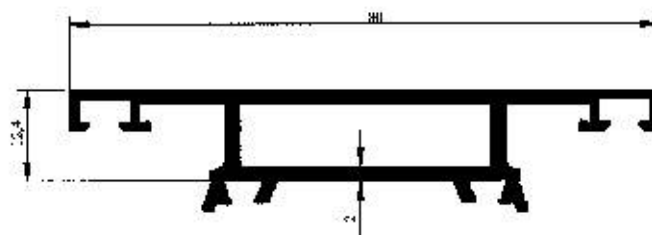

Profil No : 2314
Gramaj : 0.878 kg/m
Çevre : 274 mm

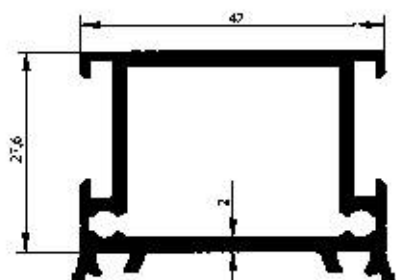

Profil No : 2312
Gramaj : 0.851 kg/m
Çevre : 210 mm

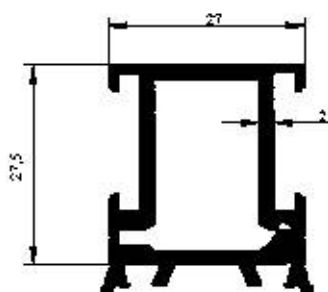

Profil No : 2316
Gramaj : 0.688 kg/m
Çevre : 180 mm

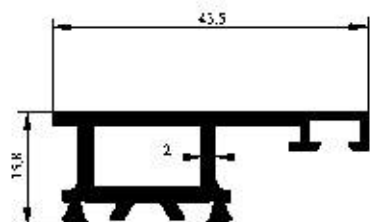

Profil No : 2318
Gramaj : 0.534 kg/m
Çevre : 170 mm

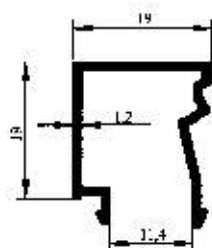

Profil No : 2332
Gramaj : 0.231 kg/m
Çevre : 141 mm

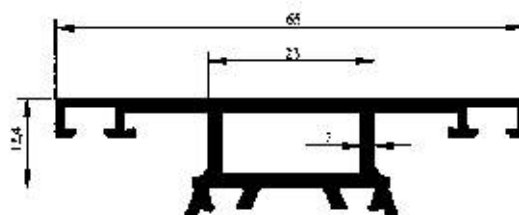

Profil No : 2315
Gramaj : 0.714 kg/m
Çevre : 244 mm

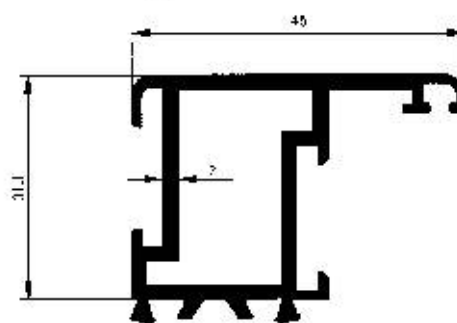

Profil No : 2317
Gramaj : 0.846 kg/m
Çevre : 241 mm

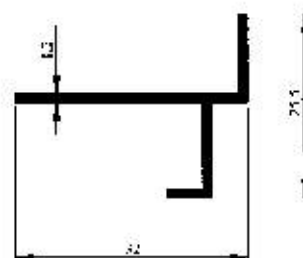

Profil No : 2323
Gramaj : 0.199 kg/m
Çevre : 125 mm

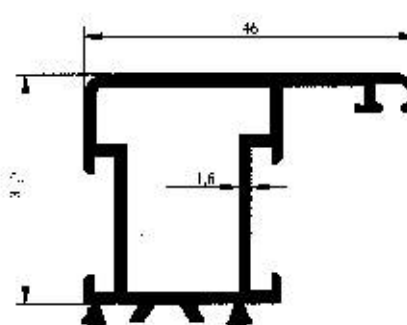

Profil No : 2335
Gramaj : 0.722 kg/m
Çevre : 237 mm

Hliníková okna a hliníkové
dveře s tepelným mostem

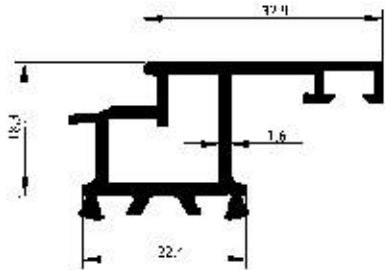

Profil No : 2336
Gramaj : 0.519 kg/m
Çevre : 184 mm

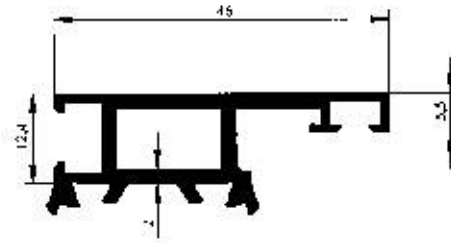

Profil No : 2337
Gramaj : 0.583 kg/m
Çevre : 195 mm

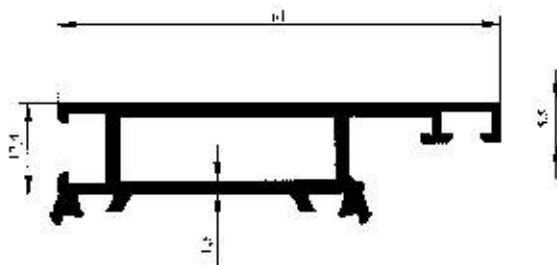

Profil No : 2338
Gramaj : 0.696 kg/m
Çevre : 225 mm

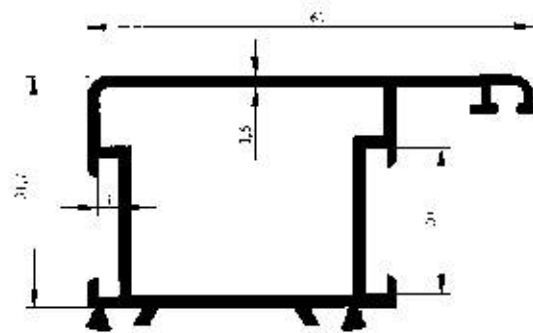

Profil No : 2339
Gramaj : 0.852 kg/m
Çevre : 267 mm

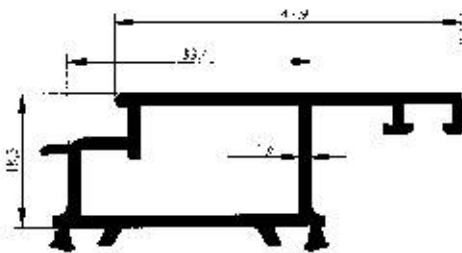

Profil No : 2340
Gramaj : 0.649 kg/m
Çevre : 214 mm

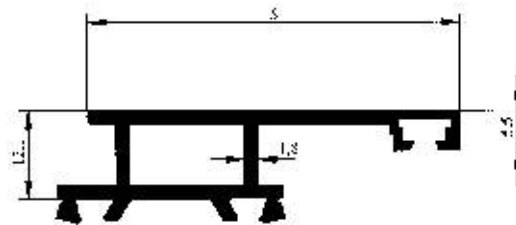

Profil No : 2341
Gramaj : 0.581 kg/m
Çevre : 200 mm

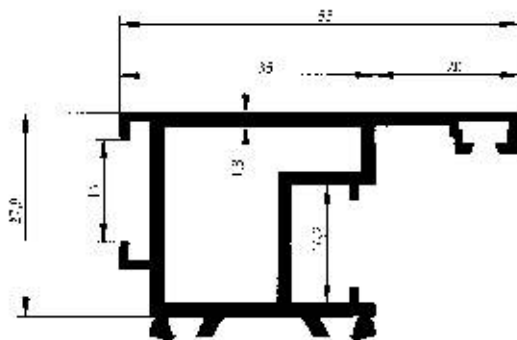

Profil No : 2342
Gramaj : 0.847 kg/m
Çevre : 266 mm

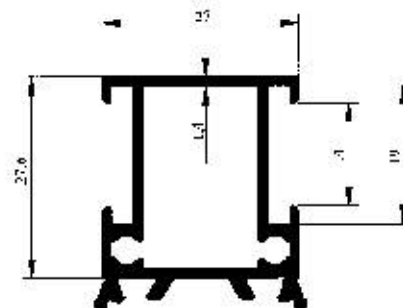

Profil No : 2346
Gramaj : 0.574 kg/m
Çevre : 179 mm

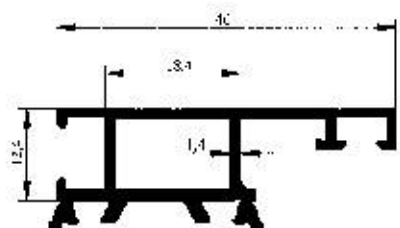

Profil No : 2347
Gramaj : 0.483 kg/m
Çevre : 197 mm

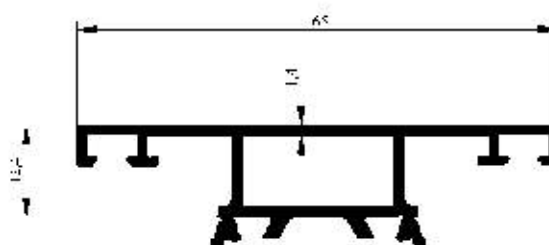

Profil No : 2348
Gramaj : 0.585 kg/m
Çevre : 245 mm

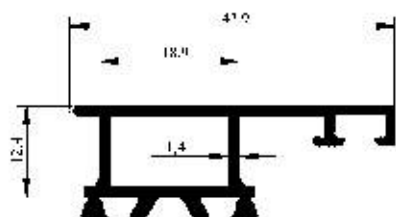

Profil No : 2349
Gramaj : 0.172 kg/m
Çevre : 256 mm

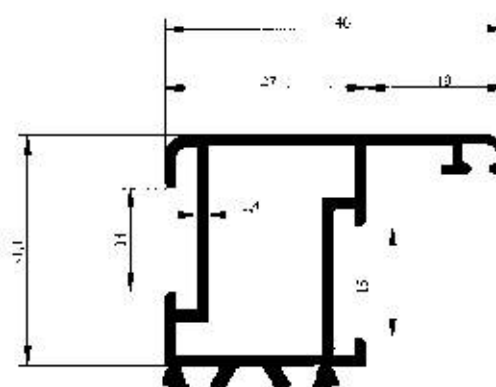

Profil No : 2350
Gramaj : 0.671 kg/m
Çevre : 242 mm

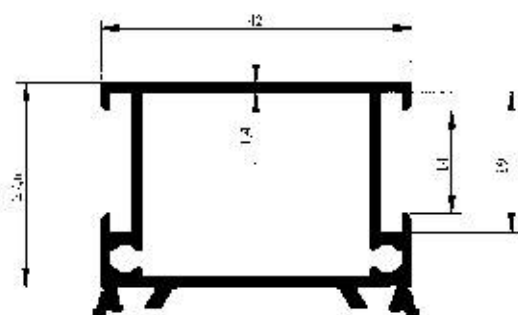

Profil No : 2351
Gramaj : 0.688 kg/m
Çevre : 203 mm

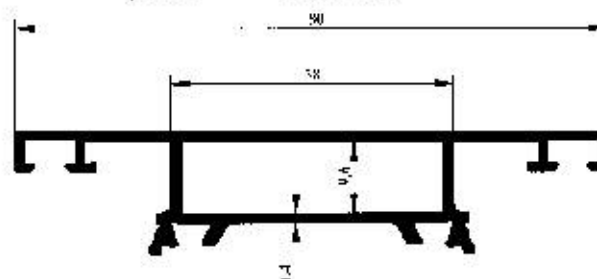

Profil No : 2352
Gramaj : 0.699 kg/m
Çevre : 275 mm

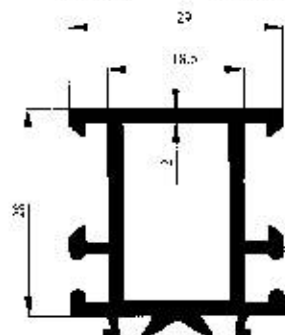

Profil No : 2360
Gramaj : 0.728 kg/m
Çevre : 203 mm

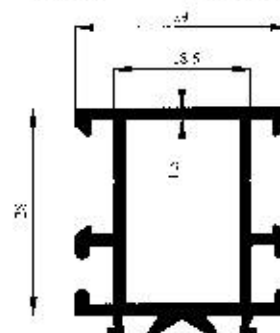

Profil No : 2361
Gramaj : 0.607 kg/m
Çevre : 205 mm

**Hliníková okna a hliníkové
dveře s tepelným mostem**

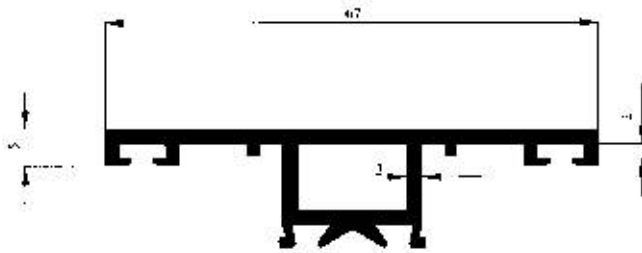

Profil No : 2362
Gramaj : 0.713 kg/m
Çevre : 229 mm

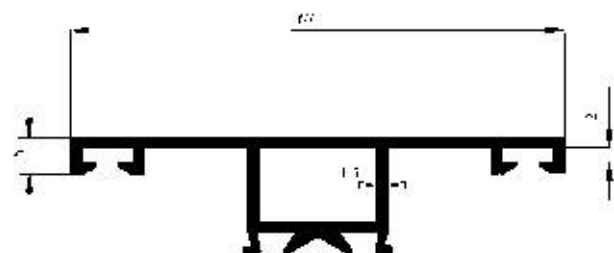

Profil No : 2363
Gramaj : 0.574 kg/m
Çevre : 228 mm

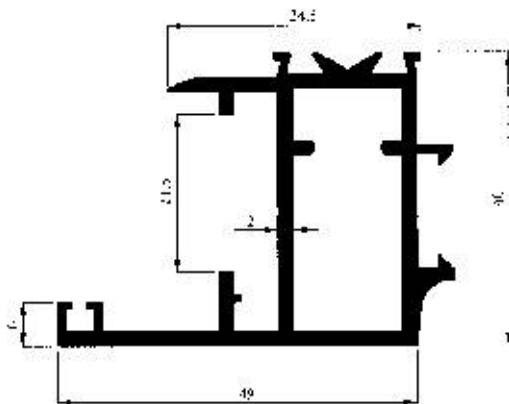

Profil No : 2364
Gramaj : 1.049 kg/m
Çevre : 295 mm

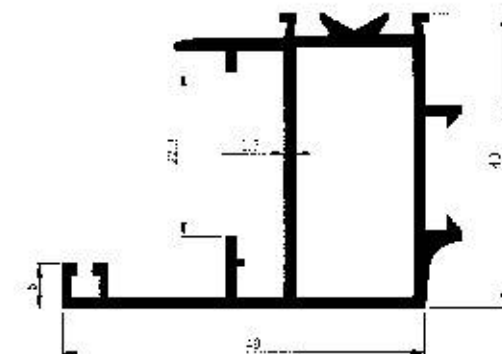

Profil No : 2365
Gramaj : 0.824 kg/m
Çevre : 297 mm



Profil No : 2366
Gramaj : 0.591 kg/m
Çevre : 176 mm

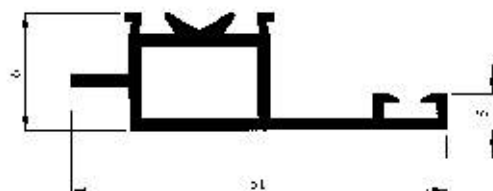

Profil No : 2367
Gramaj : 0.465 kg/m
Çevre : 177 mm

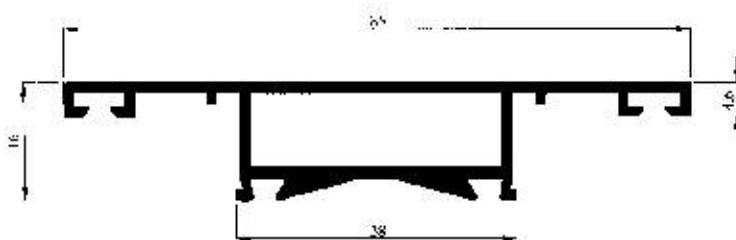

Profil No : 2371
Gramaj : 0.763 kg/m
Çevre : 268 mm

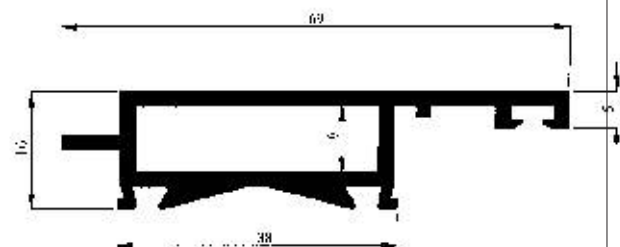

Profil No : 2374
Gramaj : 0.839 kg/m
Çevre : 210 mm

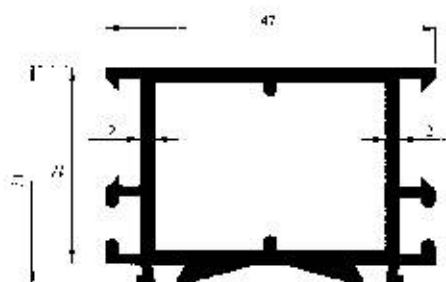

Profil No : 2368
Gramaj : 0.972 kg/m
Çevre : 236 mm

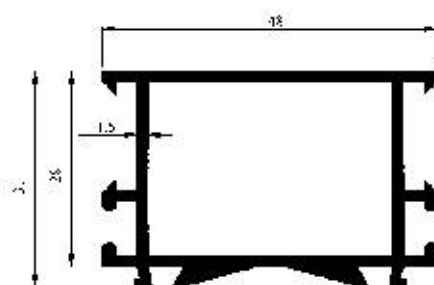

Profil No : 2369
Gramaj : 0.799 kg/m
Çevre : 238 mm

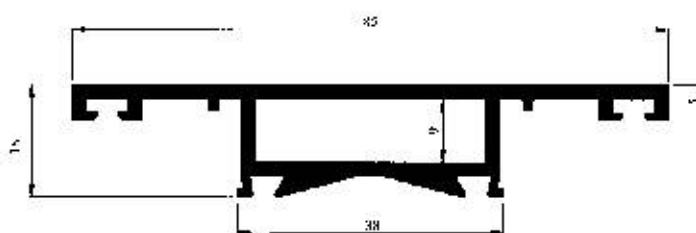

Profil No : 2370
Gramaj : 0.967 kg/m
Çevre : 262 mm

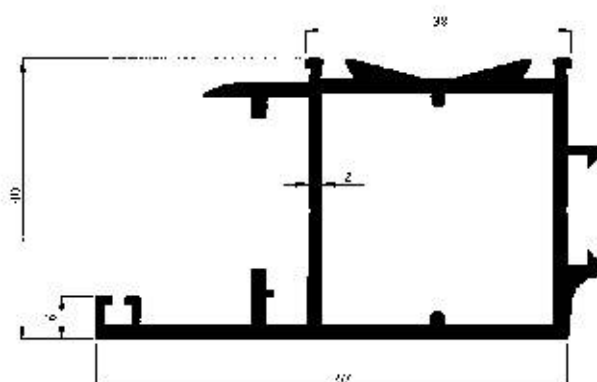

Profil No : 2372
Gramaj : 1.289 kg/m
Çevre : 330 mm

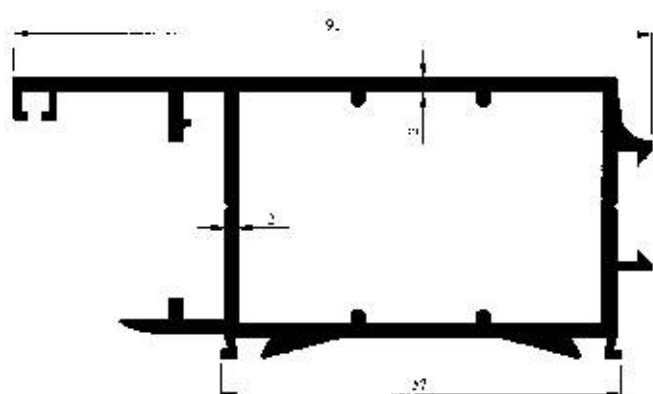

Profil No : 2373
Gramaj : 1.509 kg/m
Çevre : 368 mm

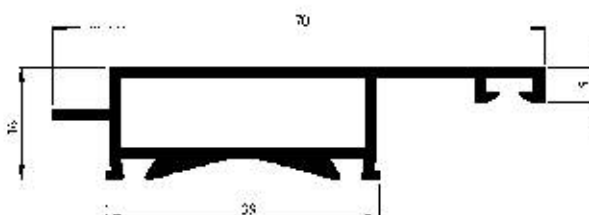

Profil No : 2375
Gramaj : 0.680 kg/m
Çevre : 213 mm

**Hliníková okna a hliníkové
dveře s tepelným mostem**

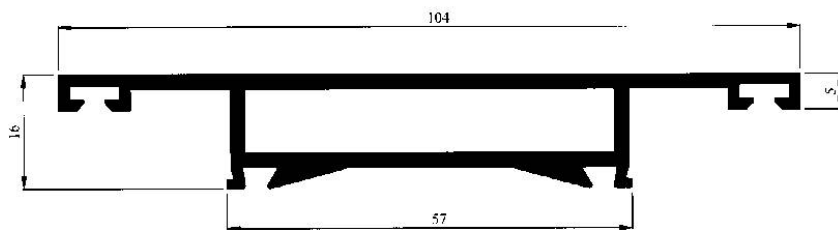

Profil No : 2376
Gramaj : 1.137 kg/m
Çevre : 299 mm

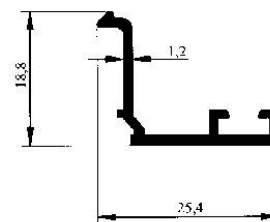

Profil No : 2402
Gramaj : 0.189 kg/m
Çevre : 106 mm

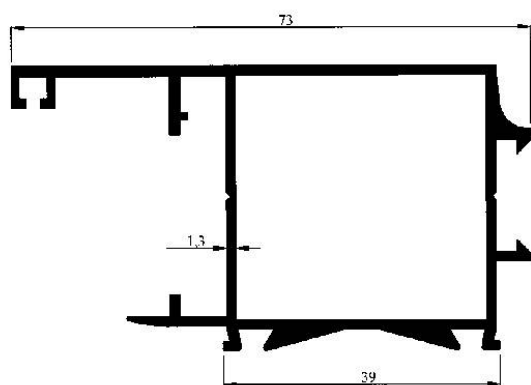

Profil No : 2377
Gramaj : 0.943 kg/m
Çevre : 333 mm

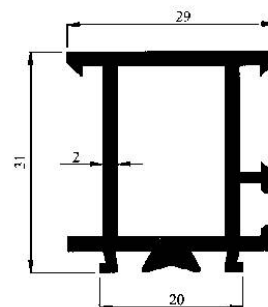

Profil No : 2406
Gramaj : 0.694 kg/m
Çevre : 179 mm

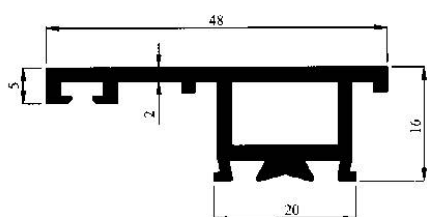

Profil No : 2407
Gramaj : 0.594 kg/m
Çevre : 170 mm

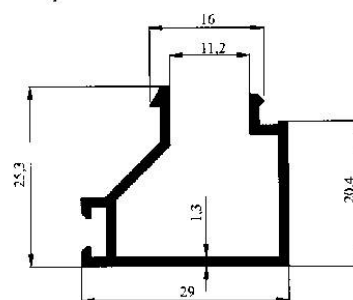

Profil No : 2413
Gramaj : 0.323 kg/m
Çevre : 184 mm

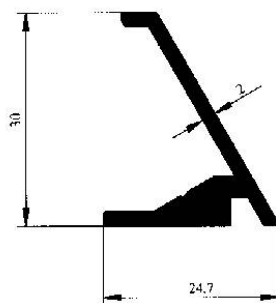

Profil No : 2417
Gramaj : 0.403 kg/m
Çevre : 122 mm

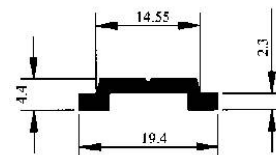

Profil No : 2416
Gramaj : 0.131 kg/m
Çevre : 52 mm

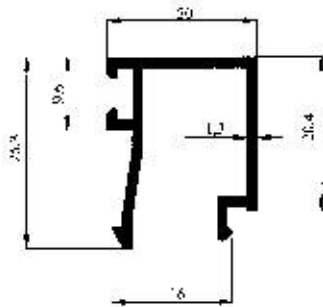

Profil No : 2415
Gramaj : 0.280 kg/m
Çevre : 160 mm

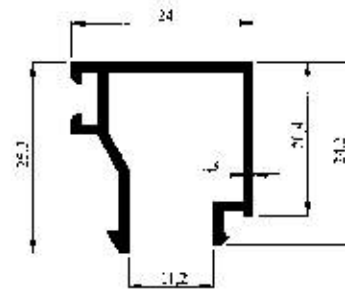

Profil No : 2414
Gramaj : 0.296 kg/m
Çevre : 169 mm

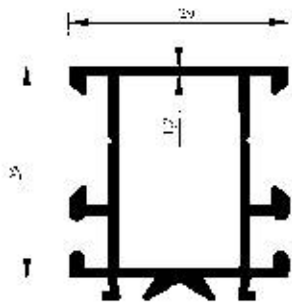

Profil No : 2440
Gramaj : 0.525 kg/m
Çevre : 210 mm

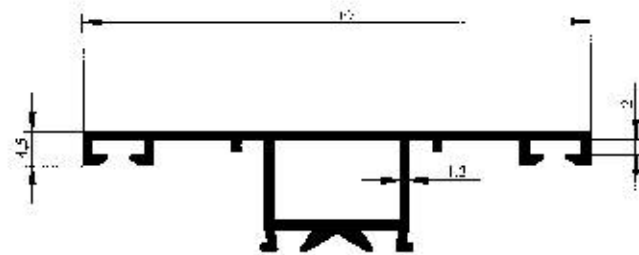

Profil No : 2441
Gramaj : 0.485 kg/m
Çevre : 233 mm

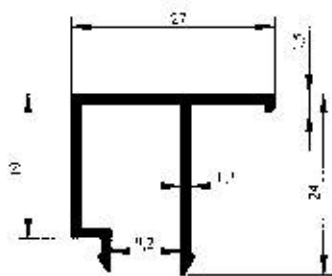

Profil No : 2442
Gramaj : 0.270 kg/m
Çevre : 155 mm

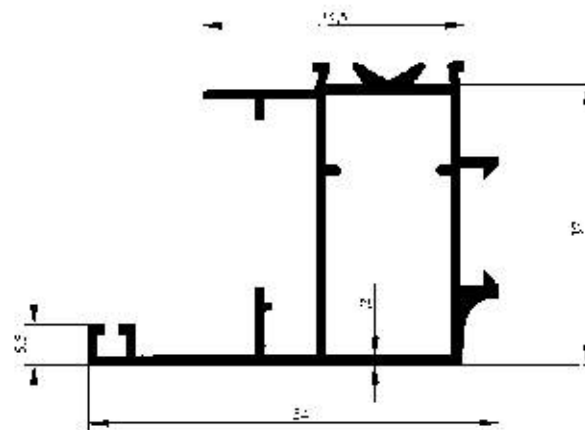

Profil No : 2443
Gramaj : 0.706 kg/m
Çevre : 300 mm

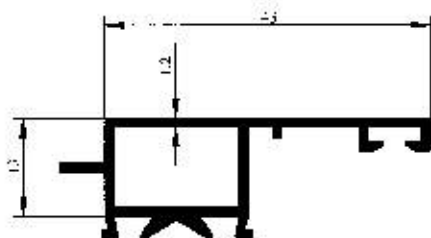

Profil No : 2444
Gramaj : 0.390 kg/m
Çevre : 174 mm

Hliníková okna a hliníkové
dveře s tepelným mostem

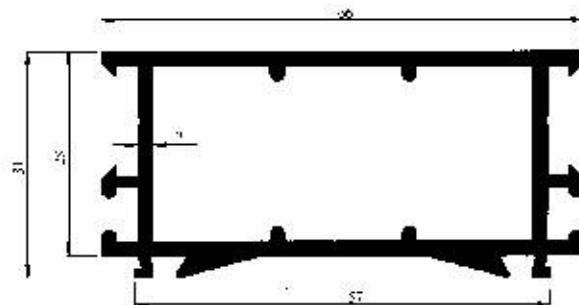
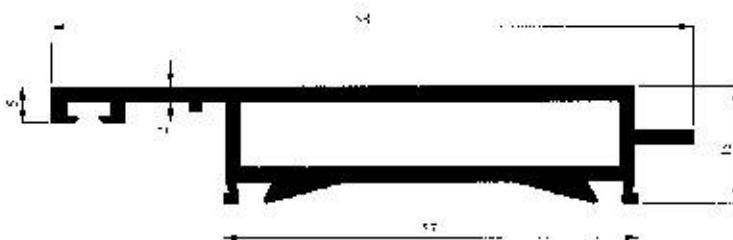
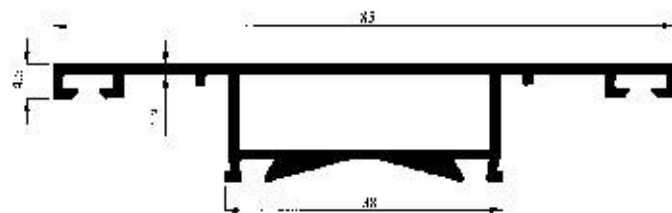
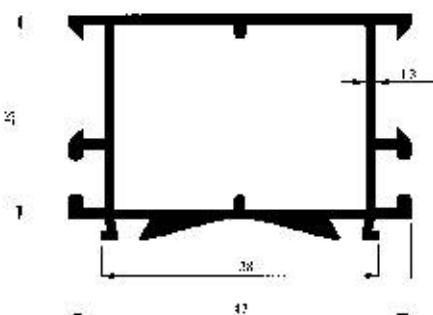
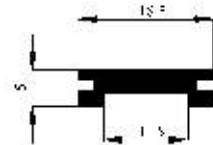
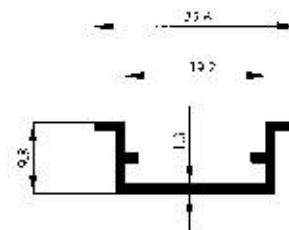
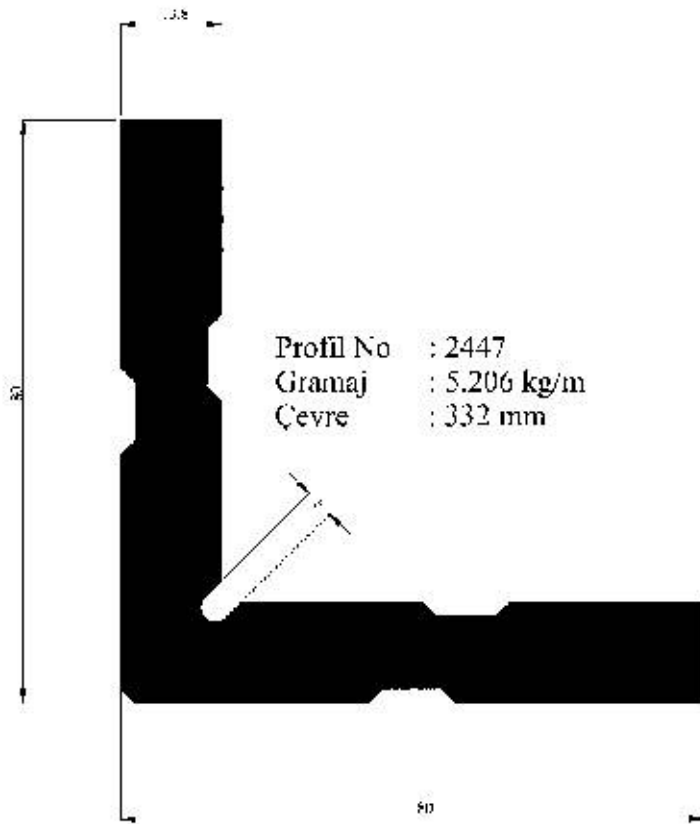

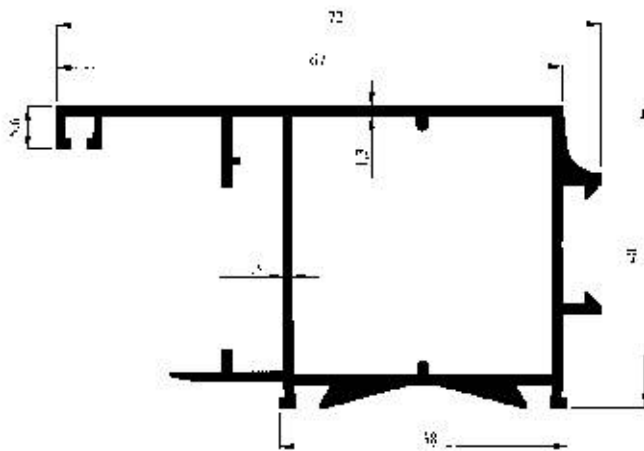

Profil No : 2452
Gramaj : 0.930 kg/m
Çevre : 334 mm

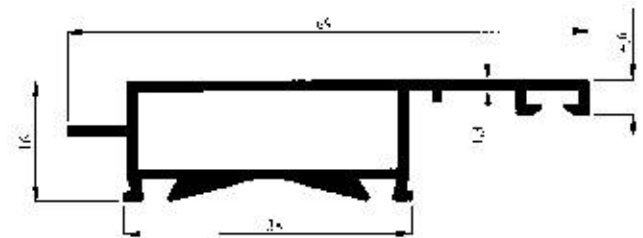

Profil No : 2453
Gramaj : 0.606 kg/m
Çevre : 213 mm

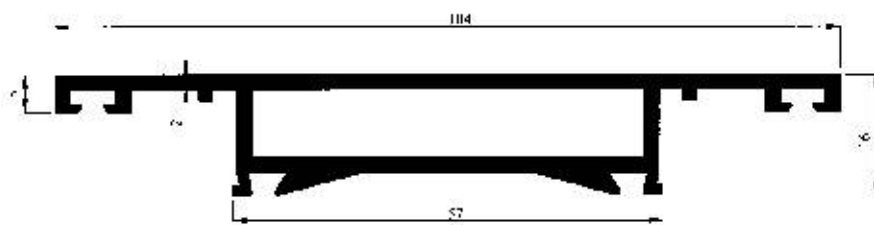

Profil No : 2455
Gramaj : 1.178 kg/m
Çevre : 301 mm

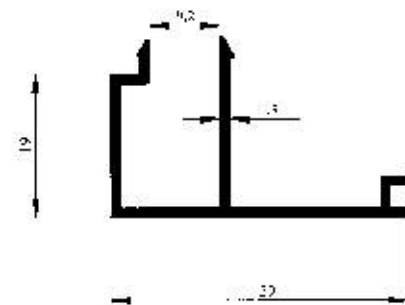

Profil No : 2458
Gramaj : 0.324 kg/m
Çevre : 192 mm

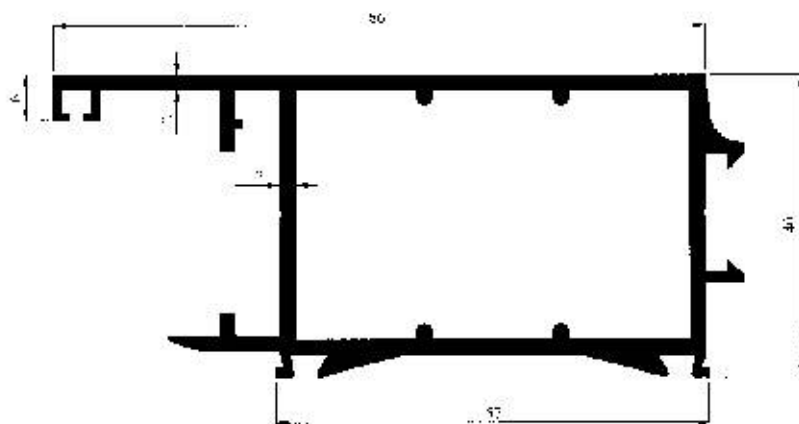

Profil No : 2456
Gramaj : 1.509 kg/m
Çevre : 368 mm

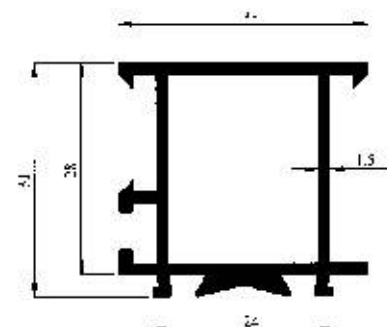

Profil No : 2468
Gramaj : 0.621 kg/m
Çevre : 191 mm

Hliníková okna a hliníkové
dveře s tepelným mostem

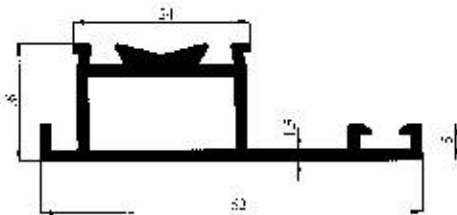

Profil No : 2469
Gramaj : 0.537 kg/m
Çevre : 181 mm

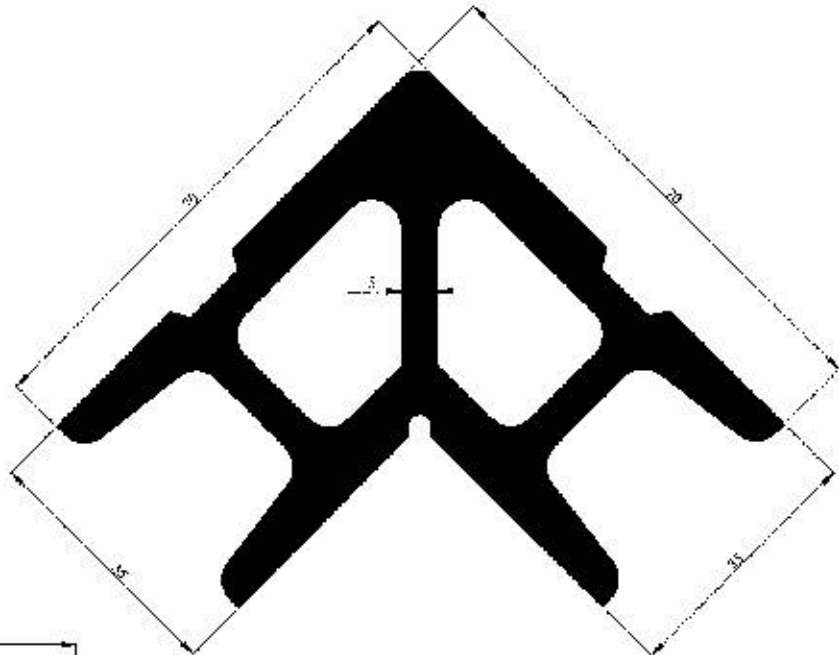

Profil No : 2470
Gramaj : 5.122 kg/m
Çevre : 348 mm

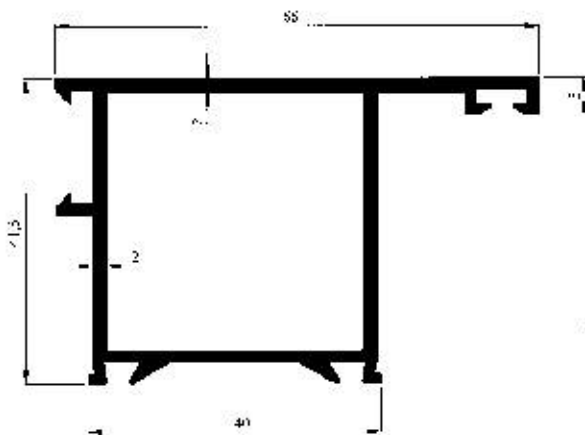

Profil No : 2471
Gramaj : 1.015 kg/m
Çevre : 270 mm



Profil No : 2472
Gramaj : 0.507 kg/m
Çevre : 182 mm

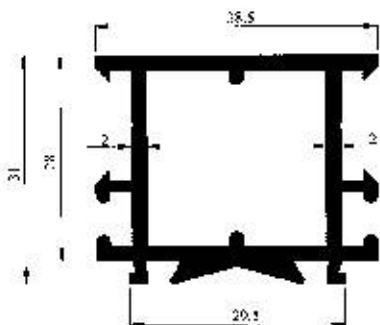

Profil No : 2491
Gramaj : 0.890 kg/m
Çevre : 215 mm

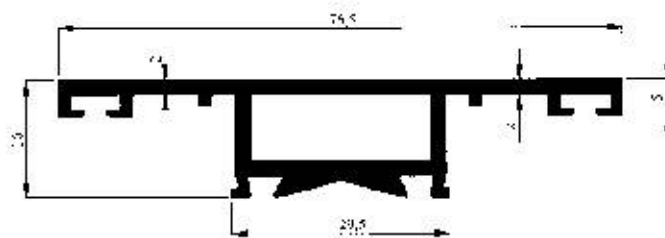

Profil No : 2492
Gramaj : 0.865 kg/m
Çevre : 249 mm

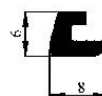
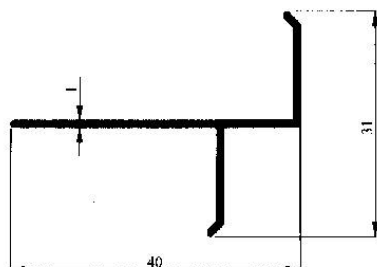

Profil No : 2526
Gramaj : 0.075 kg/m
Çevre : 30 mm

Profil No : 2504
Gramaj : 0.191 kg/m
Çevre : 142 mm

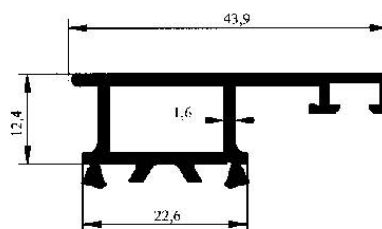
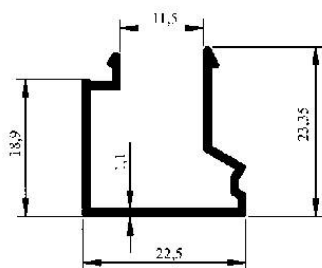

Profil No : 2534
Gramaj : 0.466 kg/m
Çevre : 172 mm

Profil No : 2531
Gramaj : 0.226 kg/m
Çevre : 150 mm

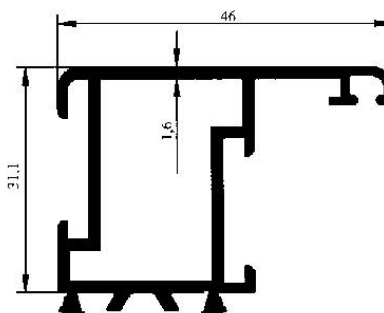
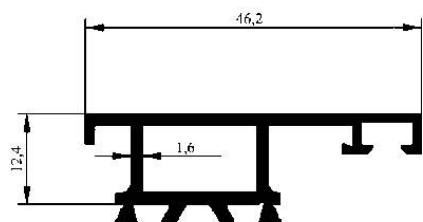

Profil No : 2535
Gramaj : 0.722 kg/m
Çevre : 243 mm

Profil No : 2536
Gramaj : 0.485 kg/m
Çevre : 181 mm

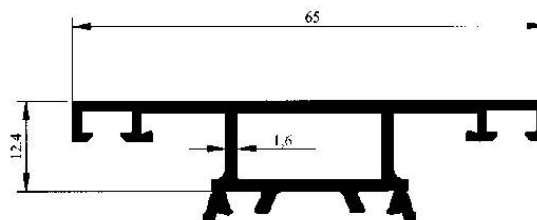
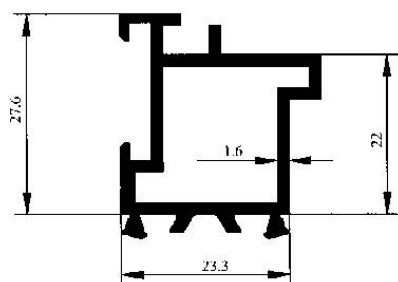

Profil No : 2538
Gramaj : 0.629 kg/m
Çevre : 245 mm

Profil No : 2537
Gramaj : 0.554 kg/m
Çevre : 169 mm

Hliníková okna a hliníkové dveře s tepelným mostem

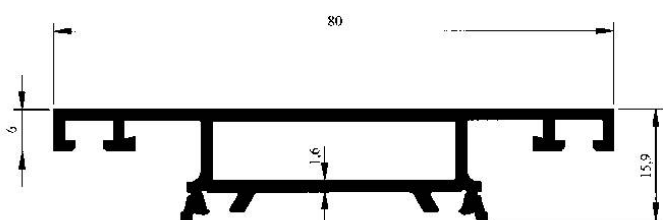

Profil No : 2566
Gramaj : 0.791 kg/m
Çevre : 278 mm

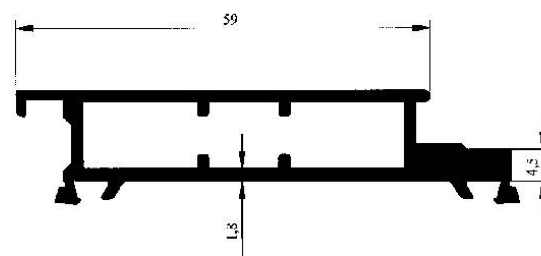

Profil No : 2540
Gramaj : 0.880 kg/m
Çevre : 204 mm

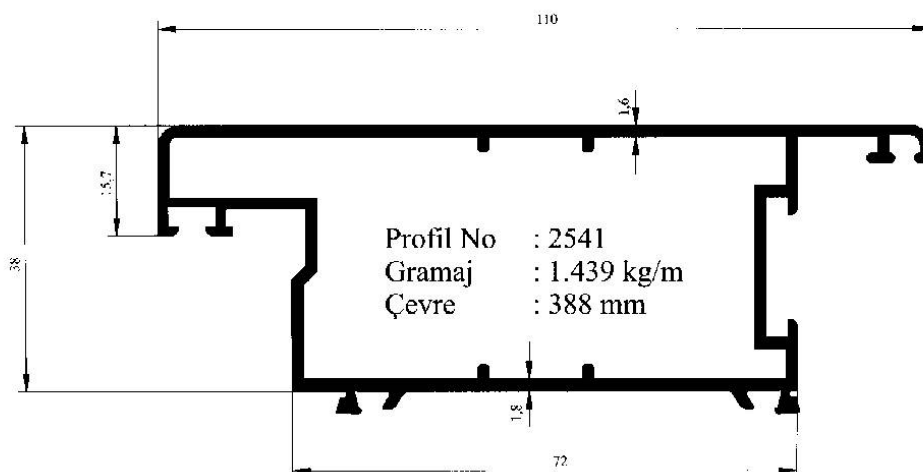

Profil No : 2541
Gramaj : 1.439 kg/m
Çevre : 388 mm

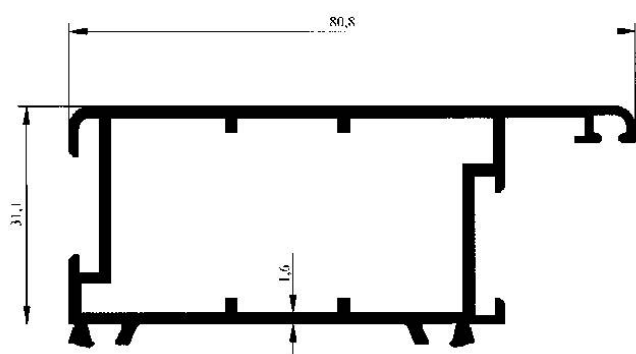

Profil No : 2542
Gramaj : 1.070 kg/m
Çevre : 311 mm

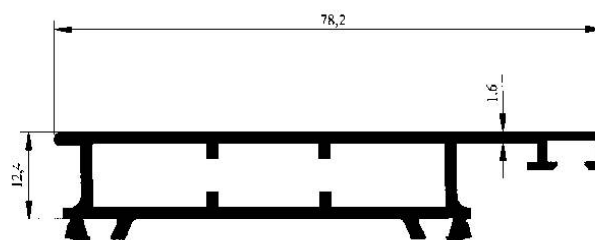

Profil No : 2543
Gramaj : 0.816 kg/m
Çevre : 241 mm

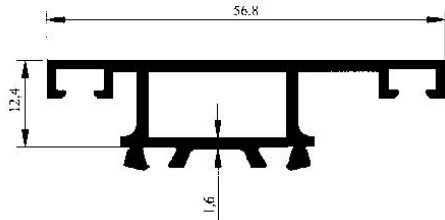

Profil No : 2544
Gramaj : 0.564 kg/m
Çevre : 216 mm

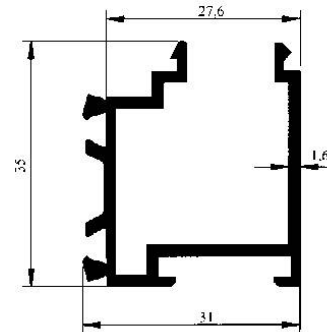

Profil No : 2545
Gramaj : 0.547 kg/m
Çevre : 263 mm

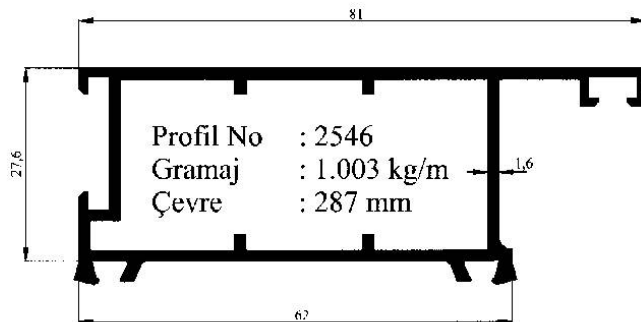

Profil No : 2546
Gramaj : 1.003 kg/m
Çevre : 287 mm

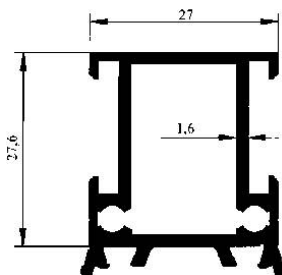

Profil No : 2539
Gramaj : 0.611 kg/m
Çevre : 169 mm

Profil No : 2554
Gramaj : 11.790 kg/m
Çevre : 358 mm

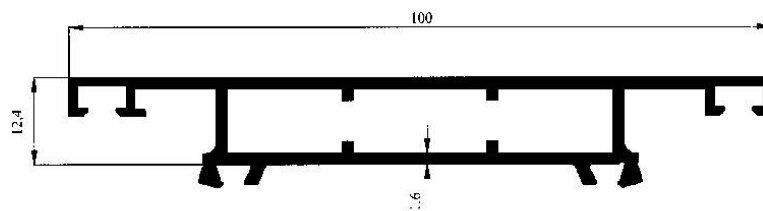
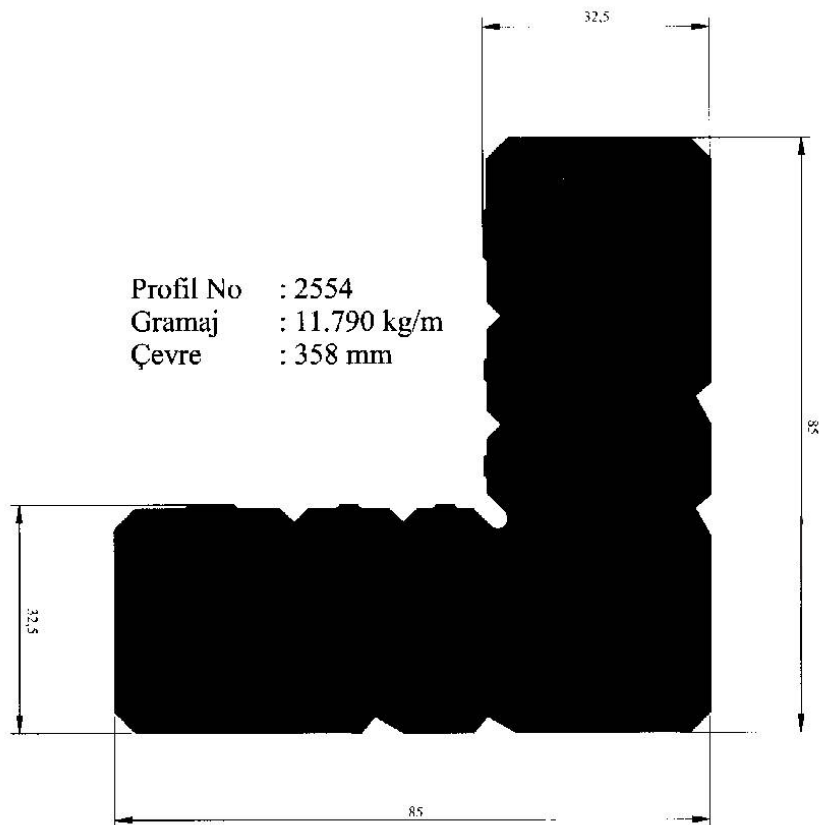

Profil No : 2547
Gramaj : 0.963 kg/m
Çevre : 306 mm

Hliníková okna a hliníkové
dveře s tepelným mostem

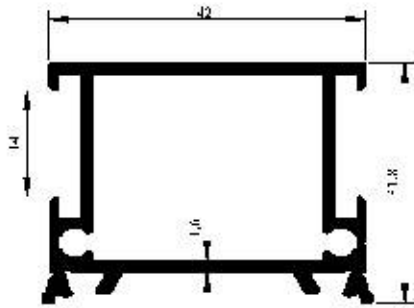

Profil No : 2567
Gramaj : 0.740 kg/m
Çevre : 209 mm

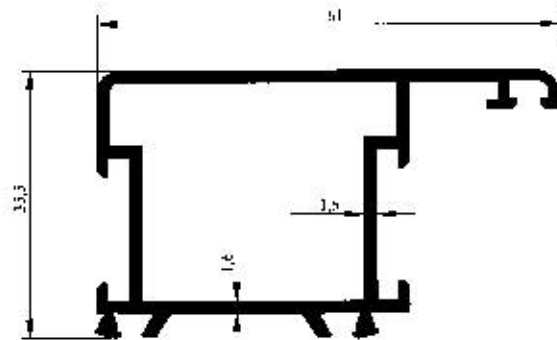

Profil No : 2572
Gramaj : 0.859 kg/m
Çevre : 270 mm

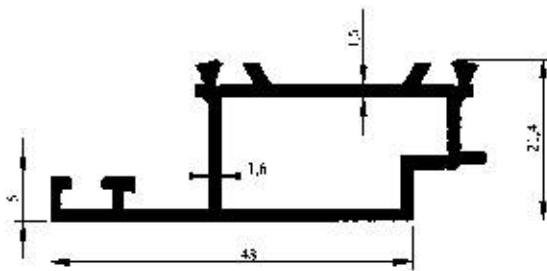

Profil No : 2573
Gramaj : 0.659 kg/m
Çevre : 214 mm

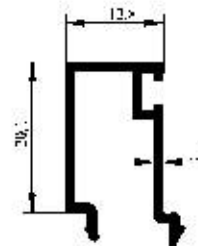

Profil No : 2576
Gramaj : 0.225 kg/m
Çevre : 138 mm

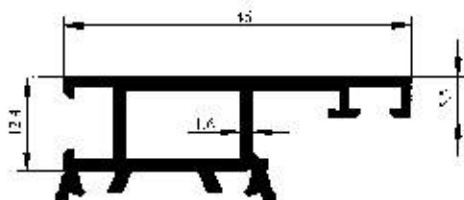

Profil No : 2584
Gramaj : 0.514 kg/m
Çevre : 198 mm

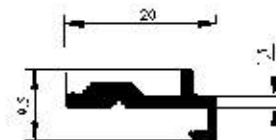

Profil No : 2587
Gramaj : 0.151 kg/m
Çevre : 65 mm

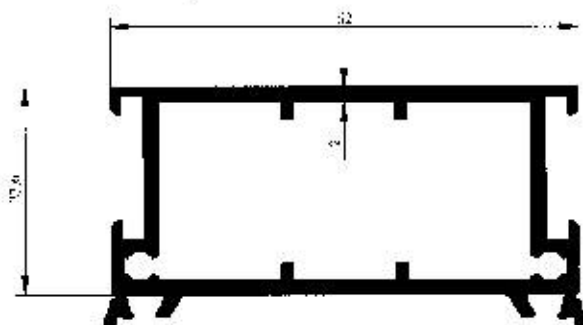

Profil No : 2588
Gramaj : 1.113 kg/m
Çevre : 249 mm

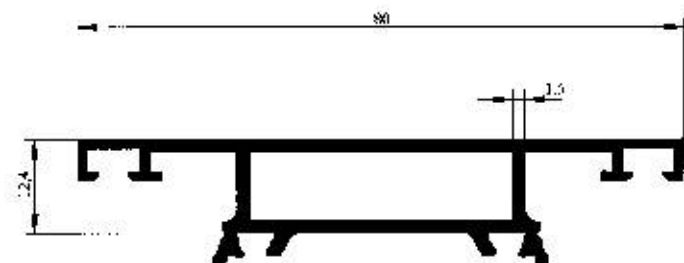

Profil No : 2590
Gramaj : 0.758 kg/m
Çevre : 275 mm

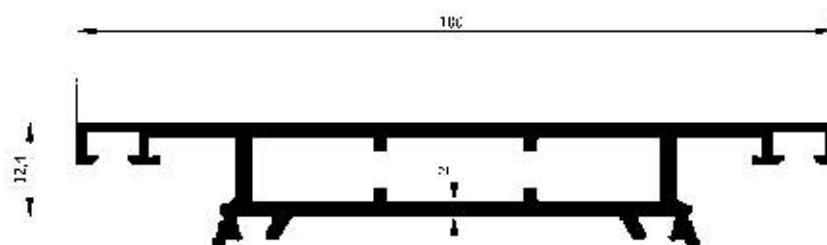

Profil No : 2589
Gramaj : 1,122 kg/m
Çevre : 314 mm

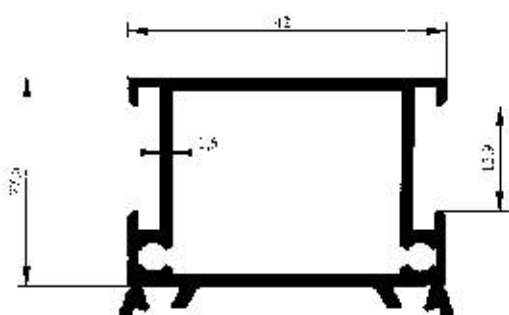

Profil No : 2591
Gramaj : 0,741 kg/m
Çevre : 209 mm

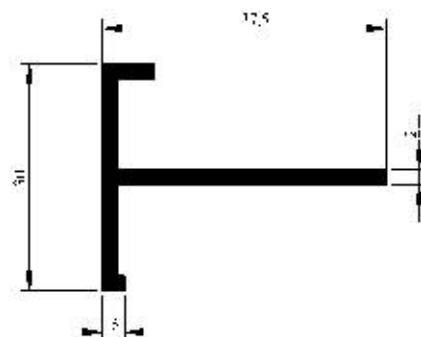

Profil No : 3284
Gramaj : 0,388 kg/m
Çevre : 147 mm

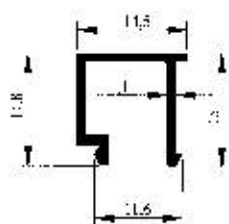

Profil No : 3560
Gramaj : 0,139 kg/m
Çevre : 93 mm

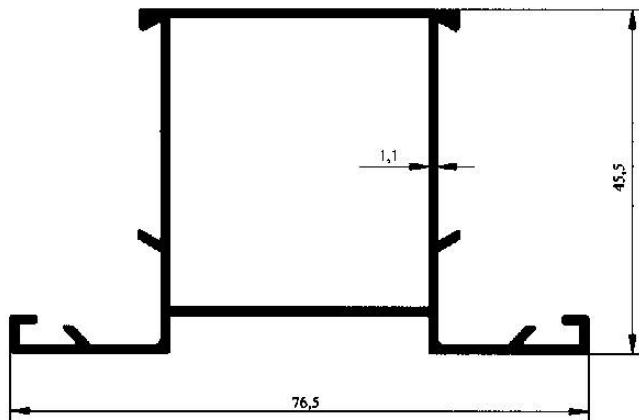

Profil No : 2019
Gramaj : 0.712 kg/m
Çevre : 315 mm

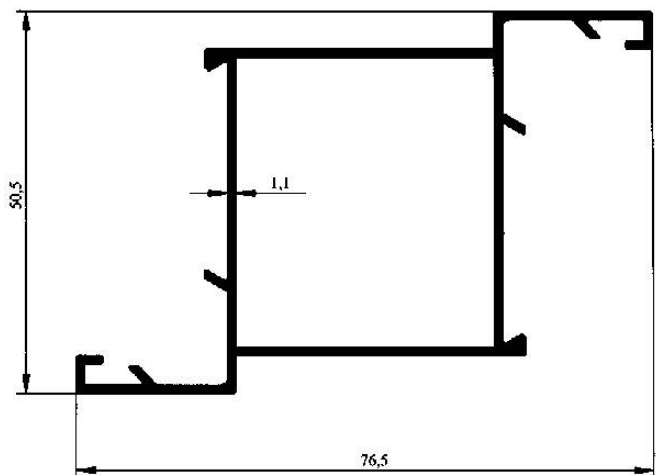

Profil No : 2020
Gramaj : 0.712 kg/m
Çevre : 315 mm

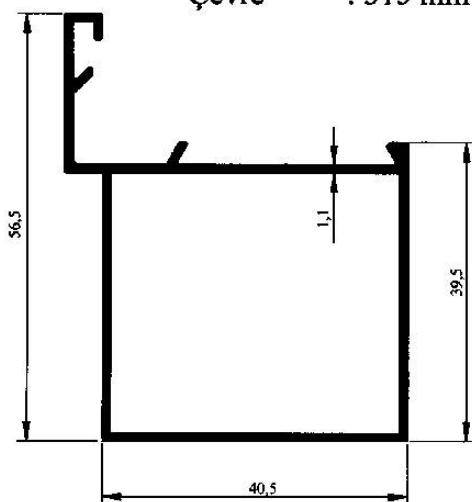

Profil No : 2021
Gramaj : 0.579 kg/m
Çevre : 234 mm

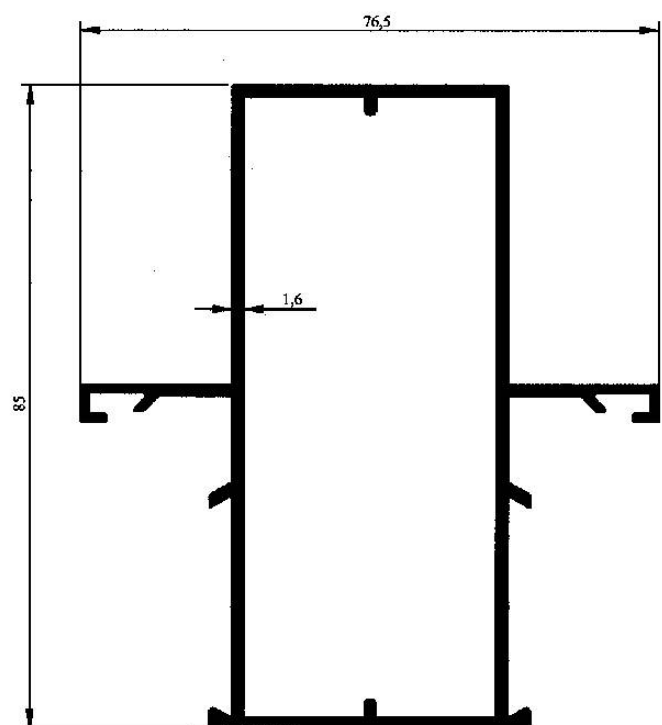

Profil No : 2022
Gramaj : 1.347 kg/m
Çevre : 383 mm

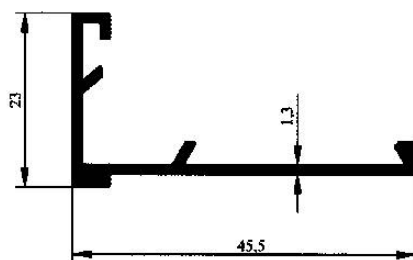

Profil No : 2026
Gramaj : 0.317 kg/m
Çevre : 168 mm